

Future High Energy Electron Proton Scattering ... The LHeC Project

Paul Newman
Birmingham University,
(for LHeC study group)



Birmingham Seminar
2 November 2011

... work in progress from ECFA/CERN/NuPECC
workshop on ep/eA physics possibilities at the LHC

<http://cern.ch/lhec>

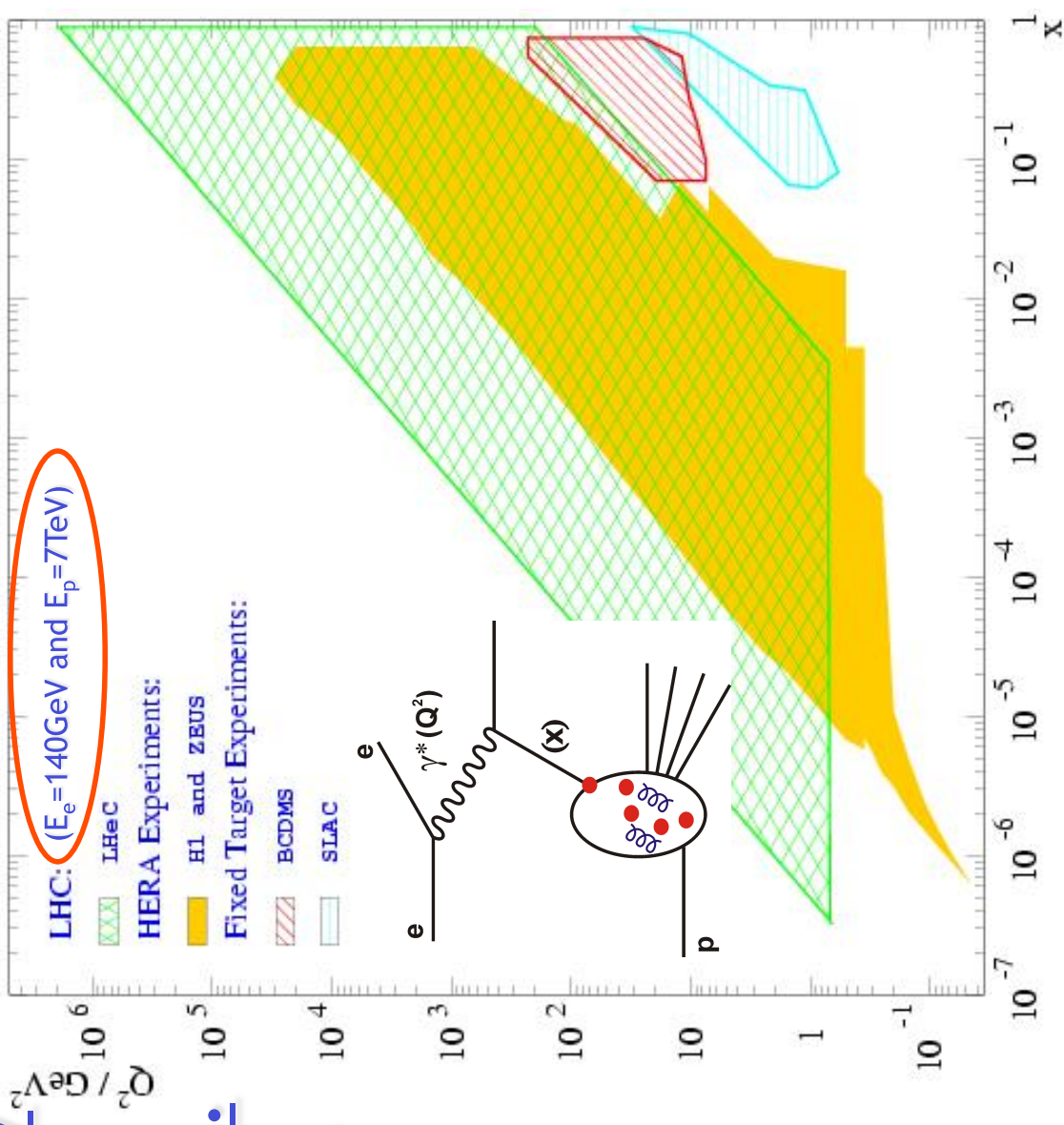

Material Taken from Draft Conceptual Design Report

1 DRAFT 1.0
2 Geneva, August 5, 2011
3 CERN report
4 ECFA report
5 NuPECC report
6 LHeC-Note-2011-001 GEN
7



- 525 pages, summarising work of ~150 participants over 5 years

- Currently under review by CERN-appointed referees → final version expected Spring 2012

- Nobody works full time on LHeC yet

8 A Large Hadron Electron Collider at CERN

9 Report on the Physics and Design
10 Concepts for Machine and Detector

11 LHeC Study Group

12 THIS IS THE VERSION FOR REFEREEING, NOT FOR DISTRIBUTION



LHeC is the latest & most promising idea to take ep physics to the TeV centre-of-mass scale ...
... at high luminosity

Contents

- A brief history of ep Physics
- How to build an ep Collider based on the LHC
- Detector considerations
- Physics motivation - BSM physics
 - Precision QCD / EW
 - Low x / high parton densities
 - Electron - ion collisions
- Timeline and outlook

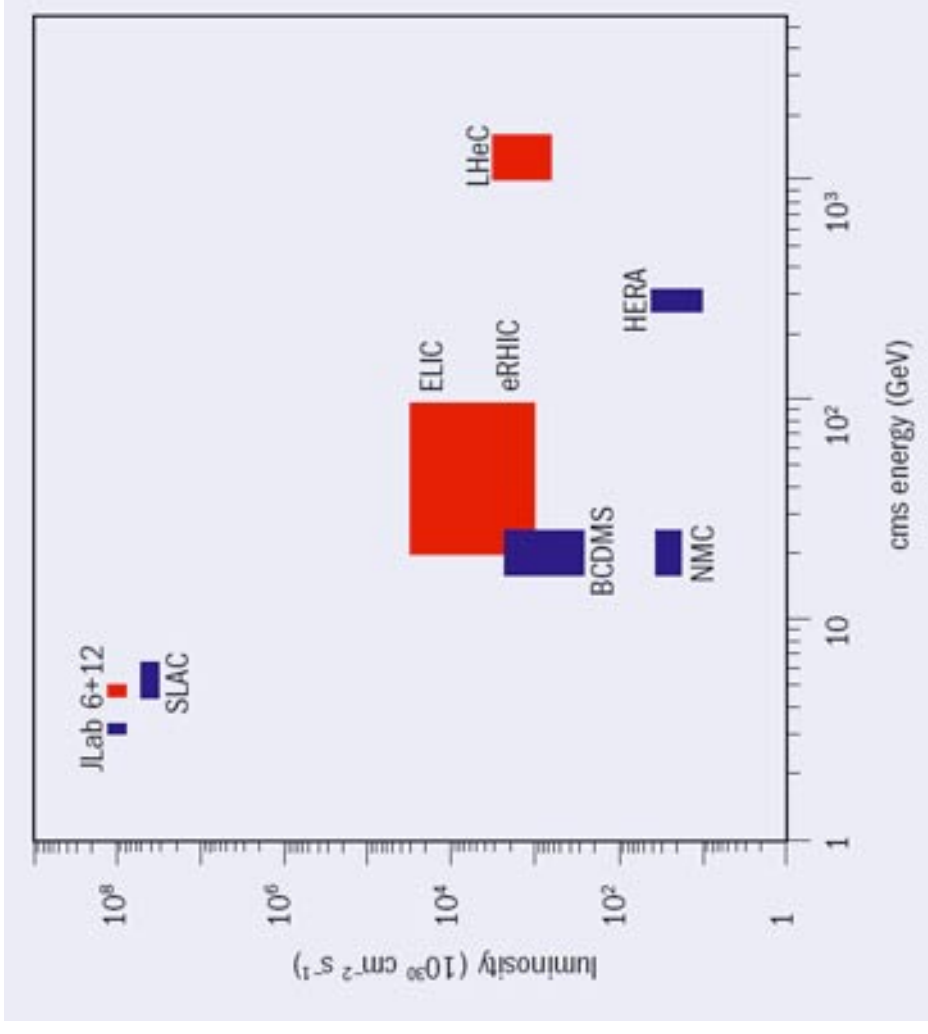

Electron Scattering Experiments

“It would be of great scientific interest if it were possible to have a supply of electrons ... of which the individual energy of motion is greater even than that of the alpha particle.”

[Ernest Rutherford, Royal Society, London, (as PRS) 30 Nov 1927]



1950s
Hoffstadter

First
observation
of finite proton size
using 2 MeV e beam

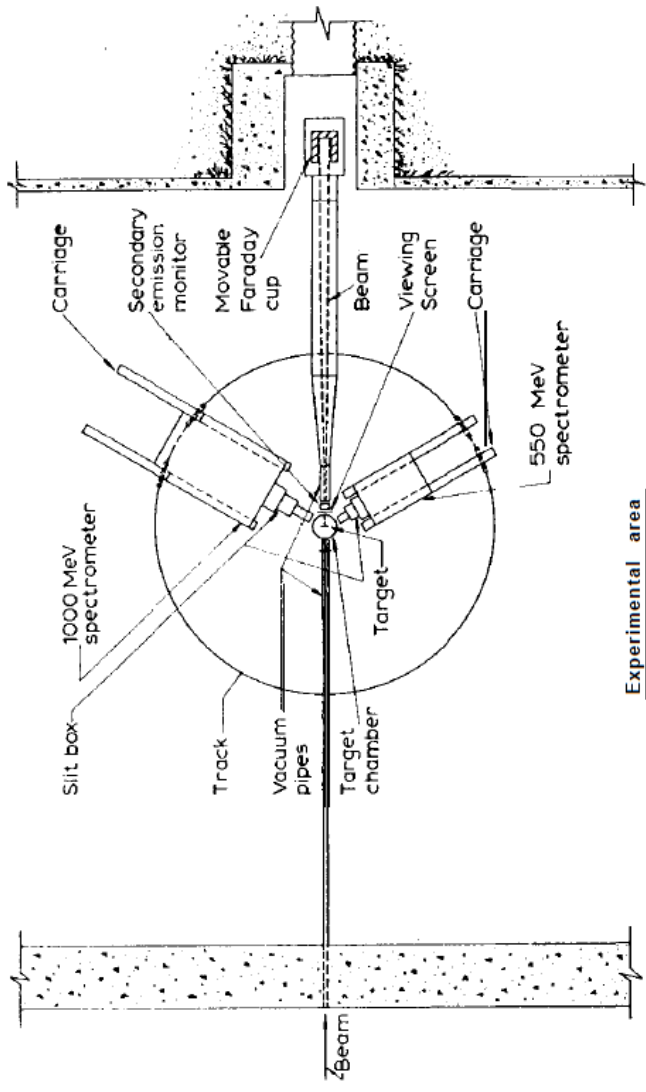
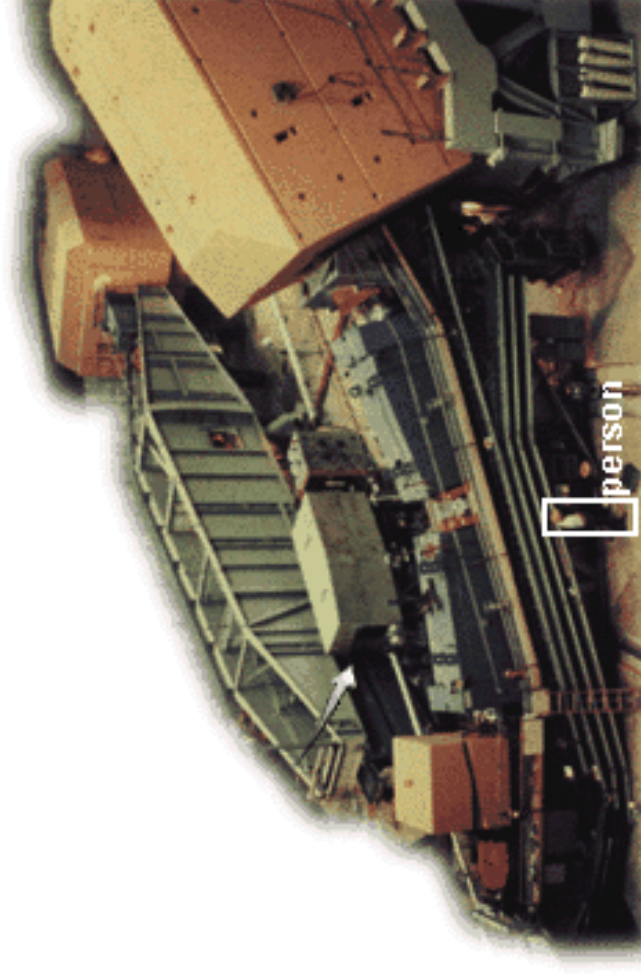
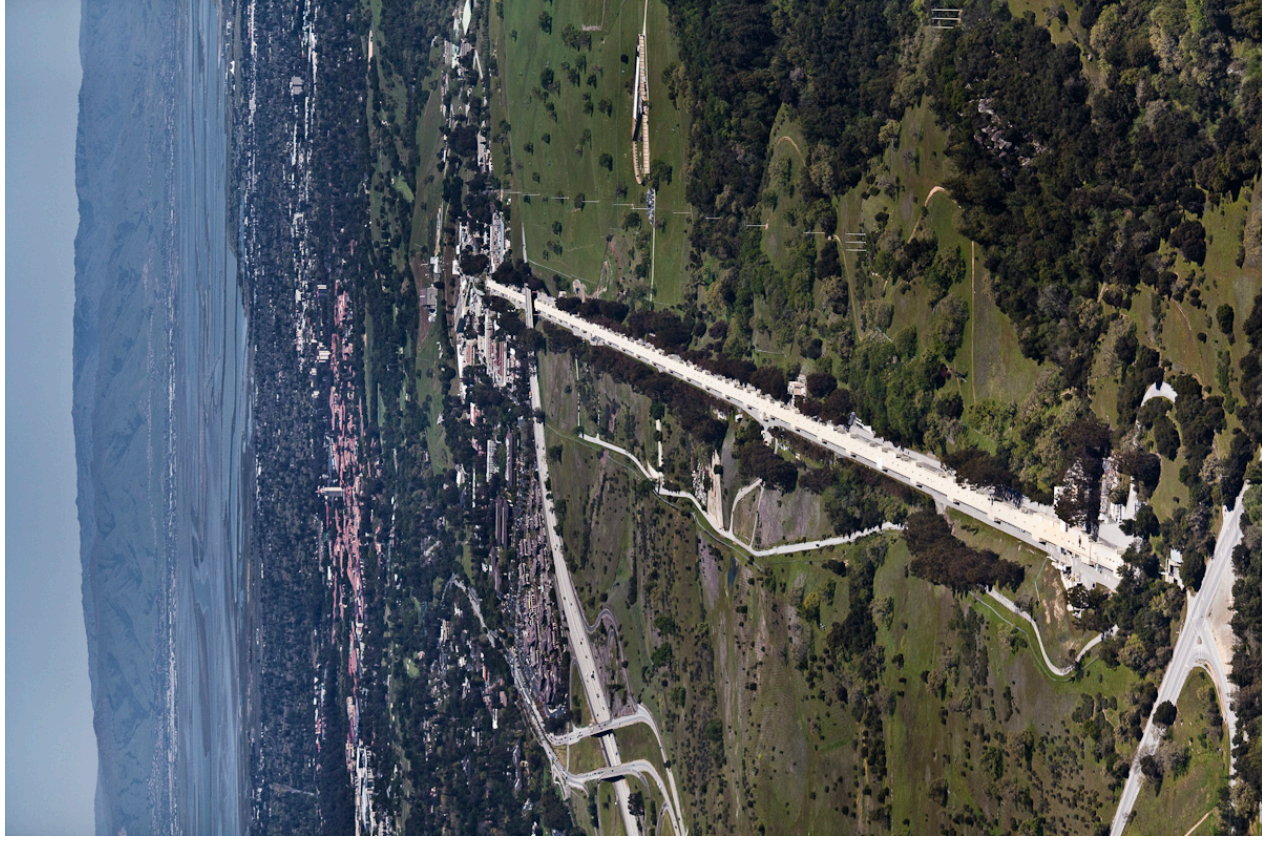

Fig. 2. This figure shows a schematic diagram of a modern electron-scattering experimental area. The track on which the spectrometers roll has an approximate radius of 13.5 feet.

SLAC 1969: Electron Energies 20 GeV



Proposal:
“A general survey of the basic cross sections which will be useful for future proposals”

First Observation Of Proton Structure

VOLUME 23, NUMBER 16

PHYSICAL REVIEW LETTERS

20 OCTOBER 1969

OBSERVED BEHAVIOR OF HIGHLY INELASTIC ELECTRON-PROTON SCATTERING

M. Breidenbach, J. I. Friedman, and H. W. Kendall

Department of Physics and Laboratory for Nuclear Science,*

Massachusetts Institute of Technology, Cambridge, Massachusetts 02139

and

E. D. Bloom, D. H. Coward, H. DeStaebler, J. Drees, L. W. Mo, and R. E. Taylor

Stanford Linear Accelerator Center,† Stanford, California 94305

(Received 22 August 1969)

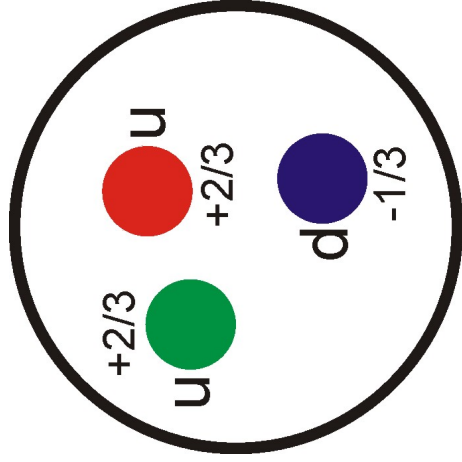

proton

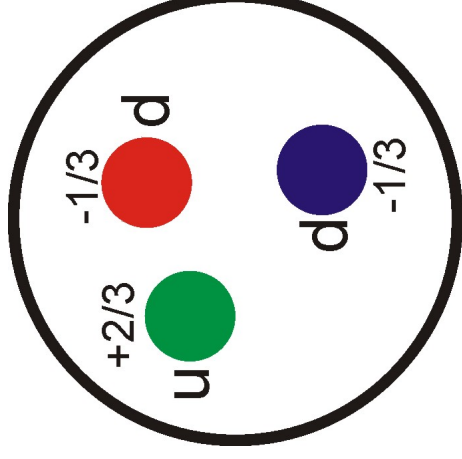

neutron

... and so on ...

DESY, Hamburg

HERA (1992-2007)

... the only ever
collider of electron
beams with proton
beams

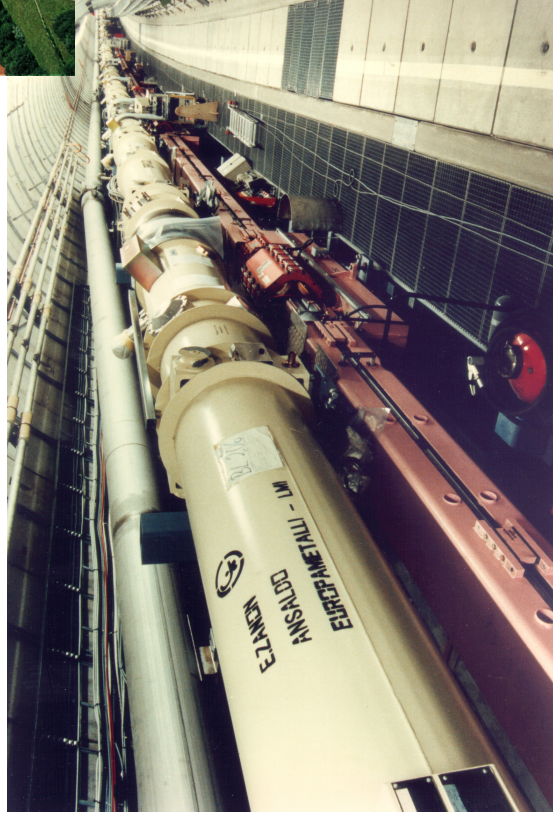
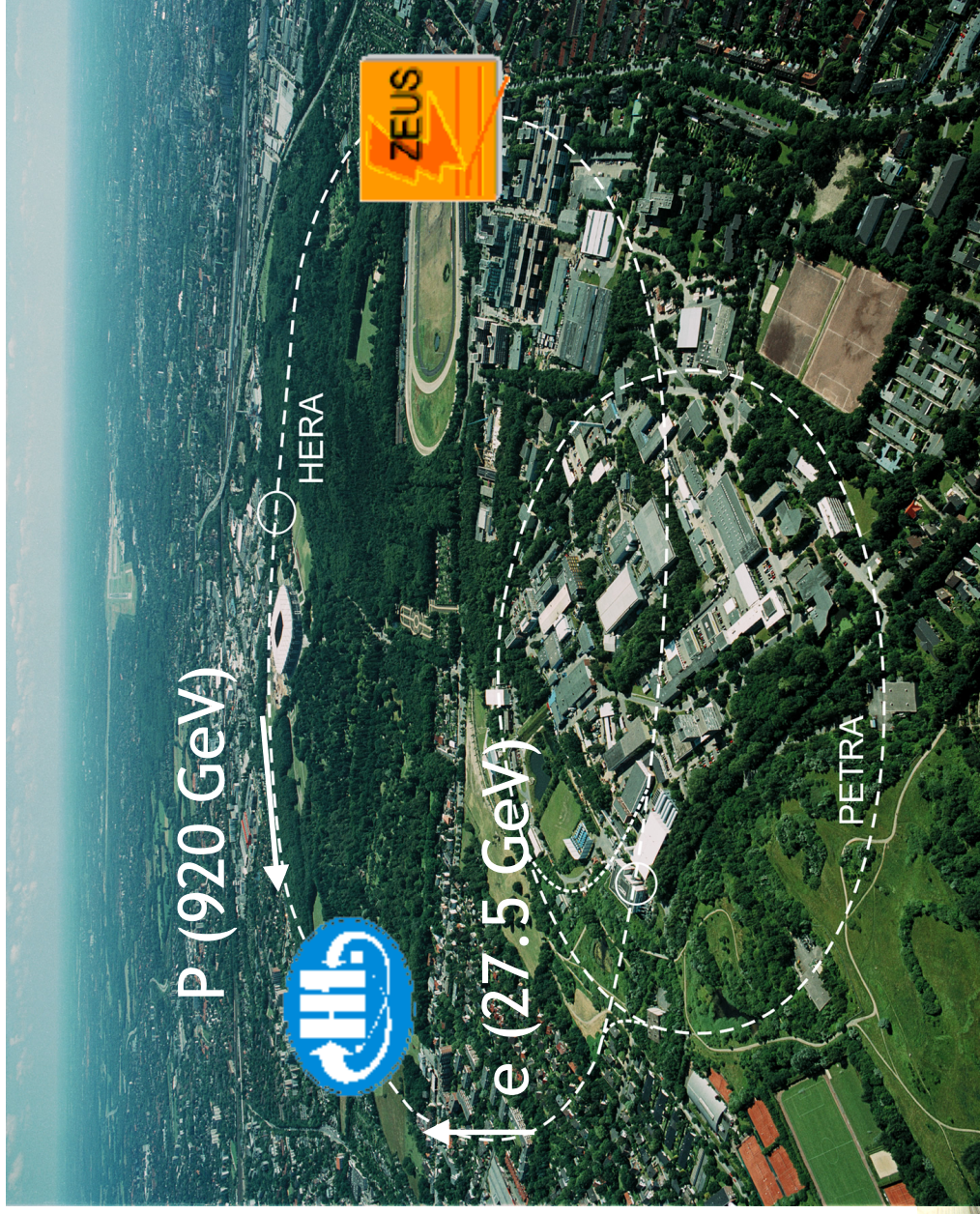

Equivalent to a 50 TeV beam on
a fixed target proton
~2500 times more than SLAC!

Around 500 pb⁻¹ per experiment

Basic Deep Inelastic Scattering Processes

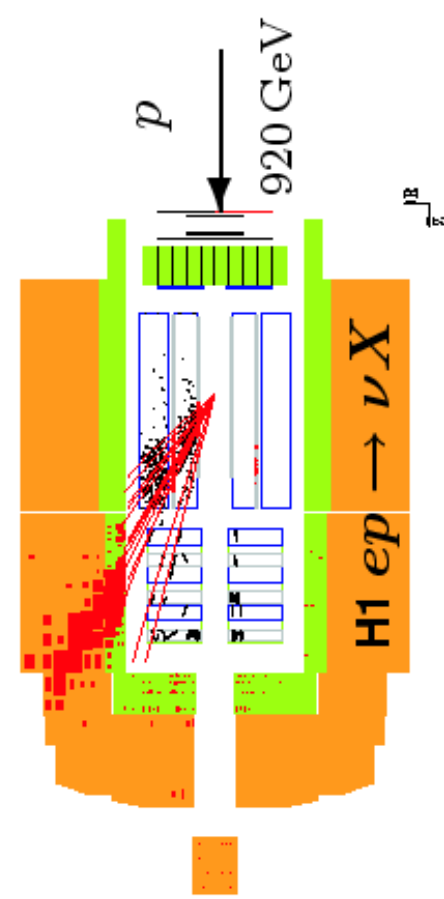
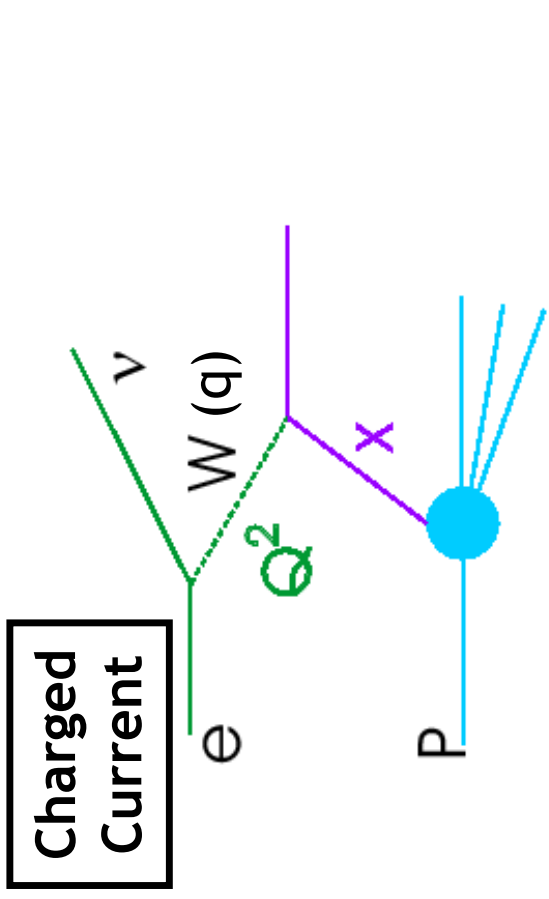
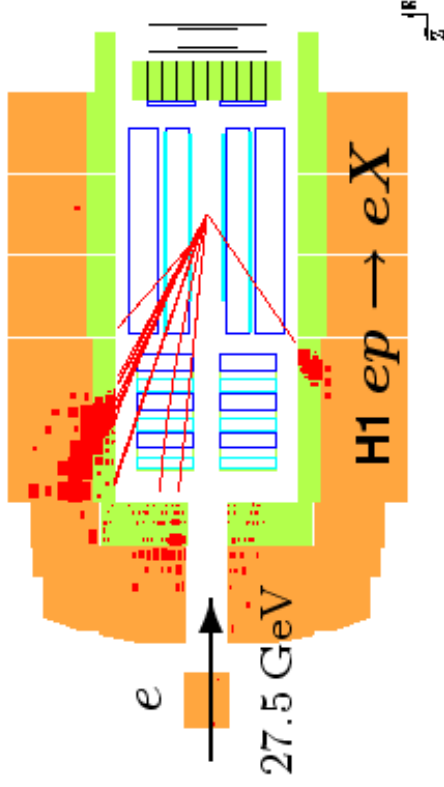
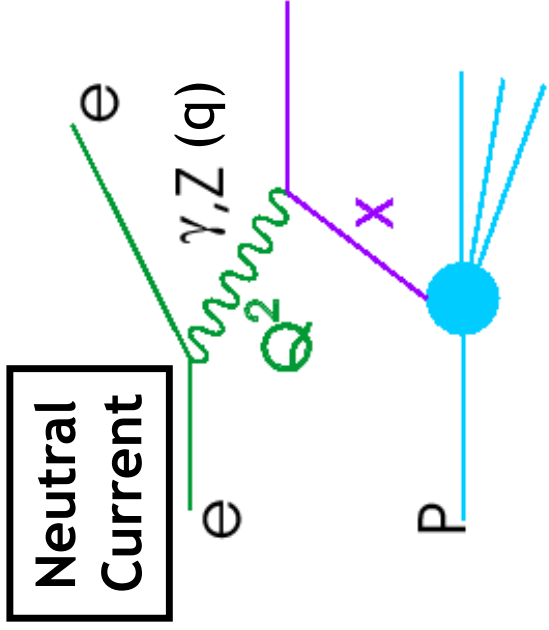

$$Q^2 = -q^2$$

:resolving power of interaction

$x = Q^2 / 2q \cdot p$: fraction of struck quark / proton momentum

Proton “Structure”?

Proton constituents ...

2 up and 1 down valence quarks

... and some gluons

... and some sea quarks

... and lots more gluons and sea quarks ...

→ strong interactions induce rich and complex ‘structure’ of high energy proton interactions!

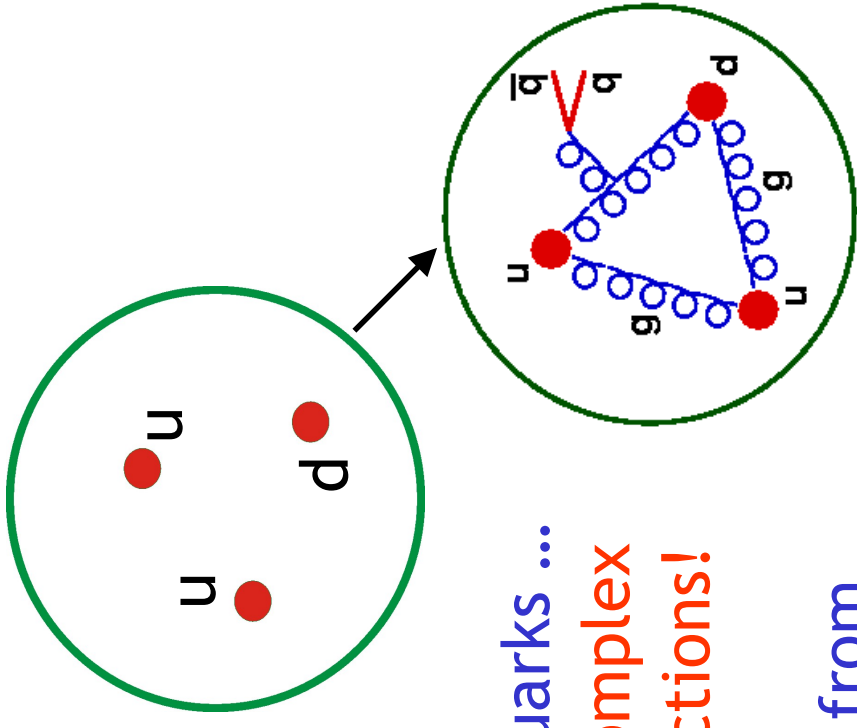

Scattering electrons from protons at $\sqrt{s} > 300\text{GeV}$ at HERA has established detailed proton structure & provided a testing ground for QCD over a huge kinematic range

... parton density functions

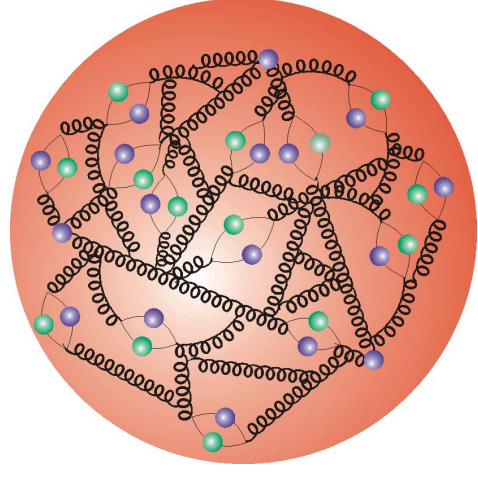
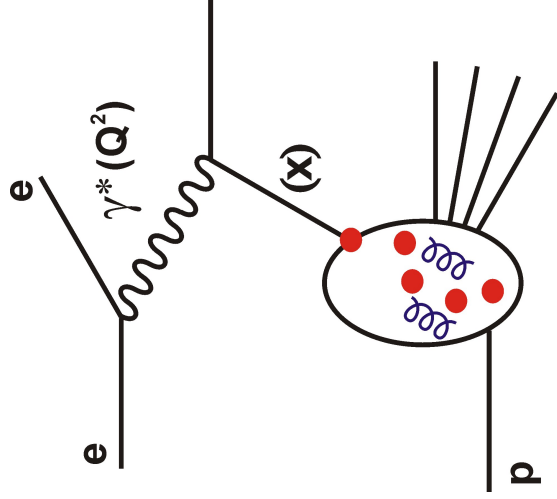

How is the Proton's Energy Shared out?

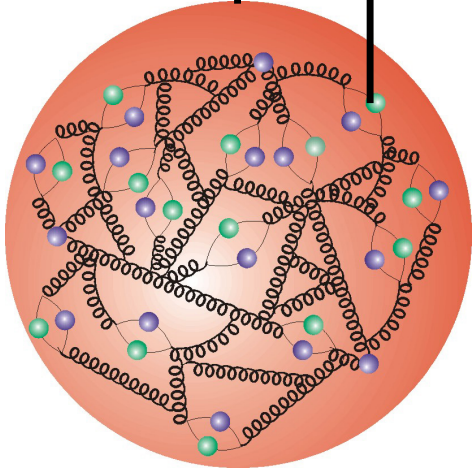

A proton with high energy

A quark carrying energy fraction, x

Energy carried by quarks and gluons as a function of $x \rightarrow$

At TeV / LHC energies, a proton looks like a lot of gluons

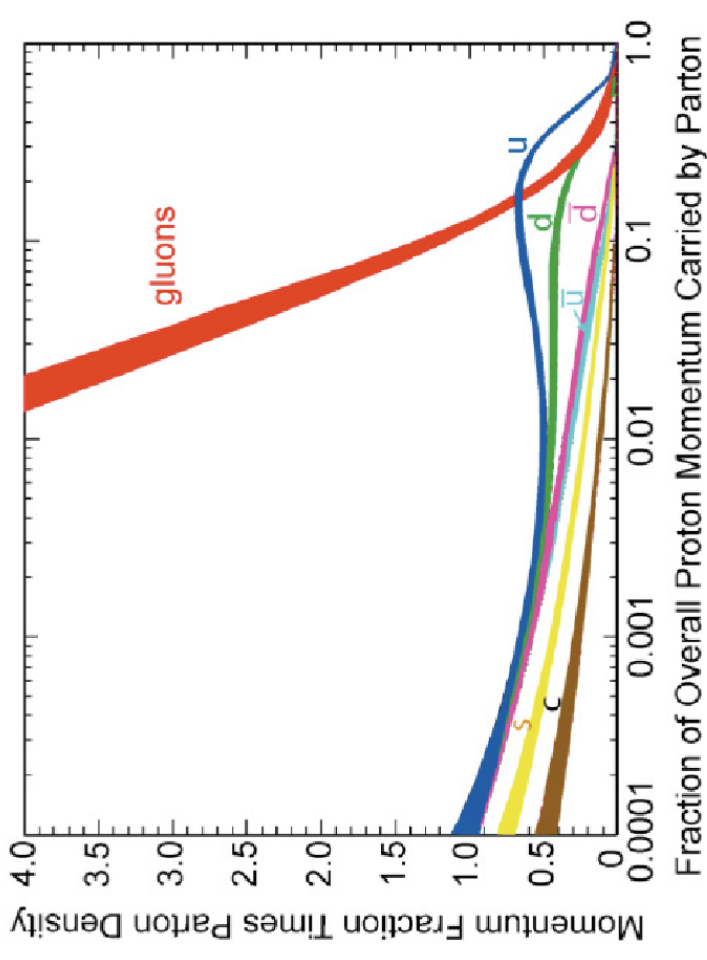

HERA's greatest legacy

Parton densities of proton in a large x range

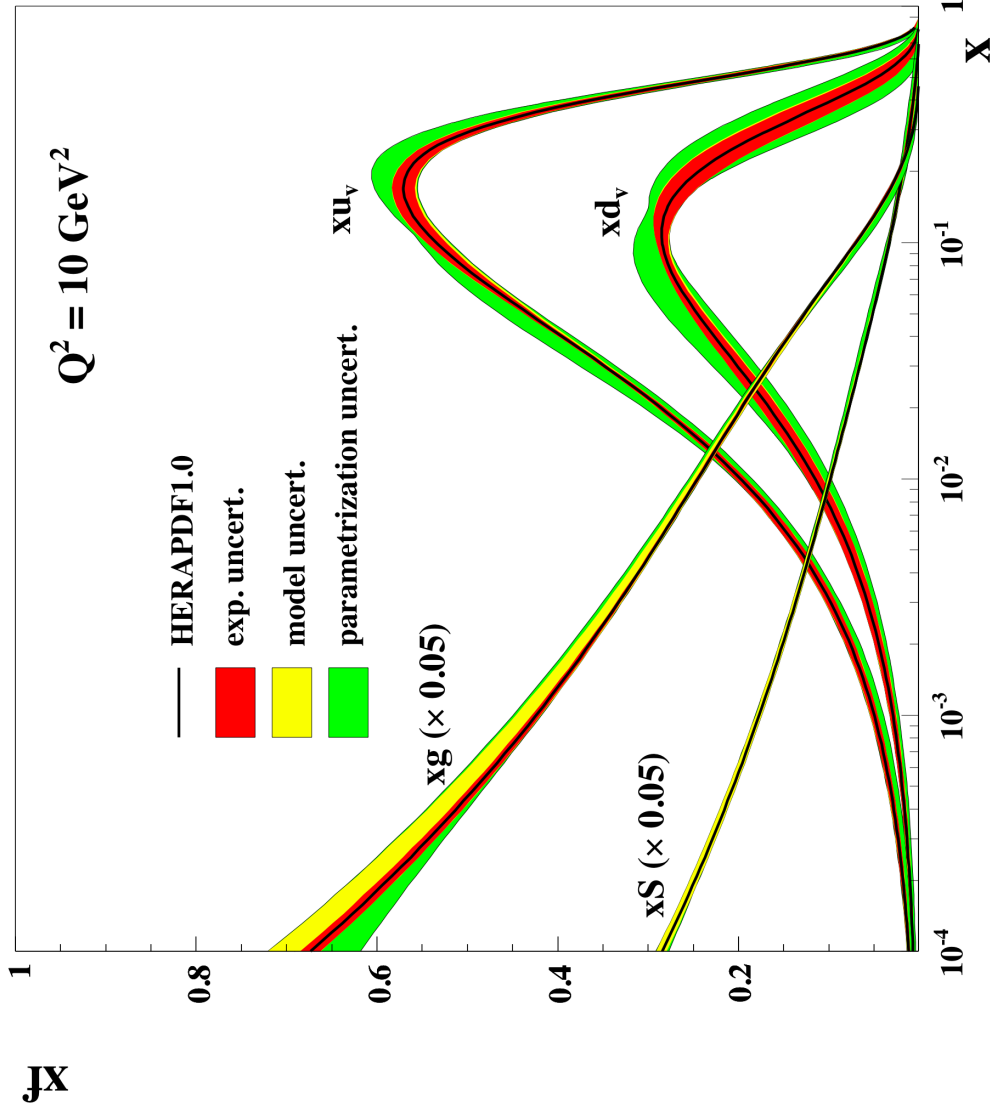

Some limitations:

- Insufficient lumi for high x precision
- Assumptions on quark Flavour decomposition
- No deuterons ... u and d not separated
- No heavy ions

- H1 / ZEUS / joint publications still coming for 1-2 years
- Further progress requires higher energy and luminosity ...

HERA kinematic range

- Unprecedented low x and high Q^2 coverage in DIS!
- **HERA + QCD factorisation**
 → parton densities in full x range of LHC rapidity plateau

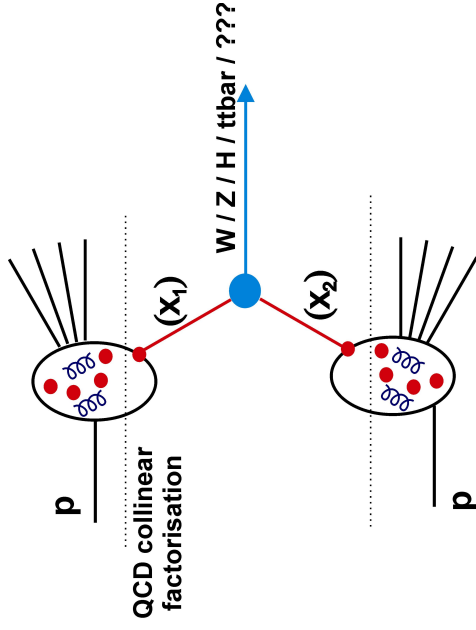

- Well established 'DGLAP' evolution equations generalise to any scale (for not too small x)

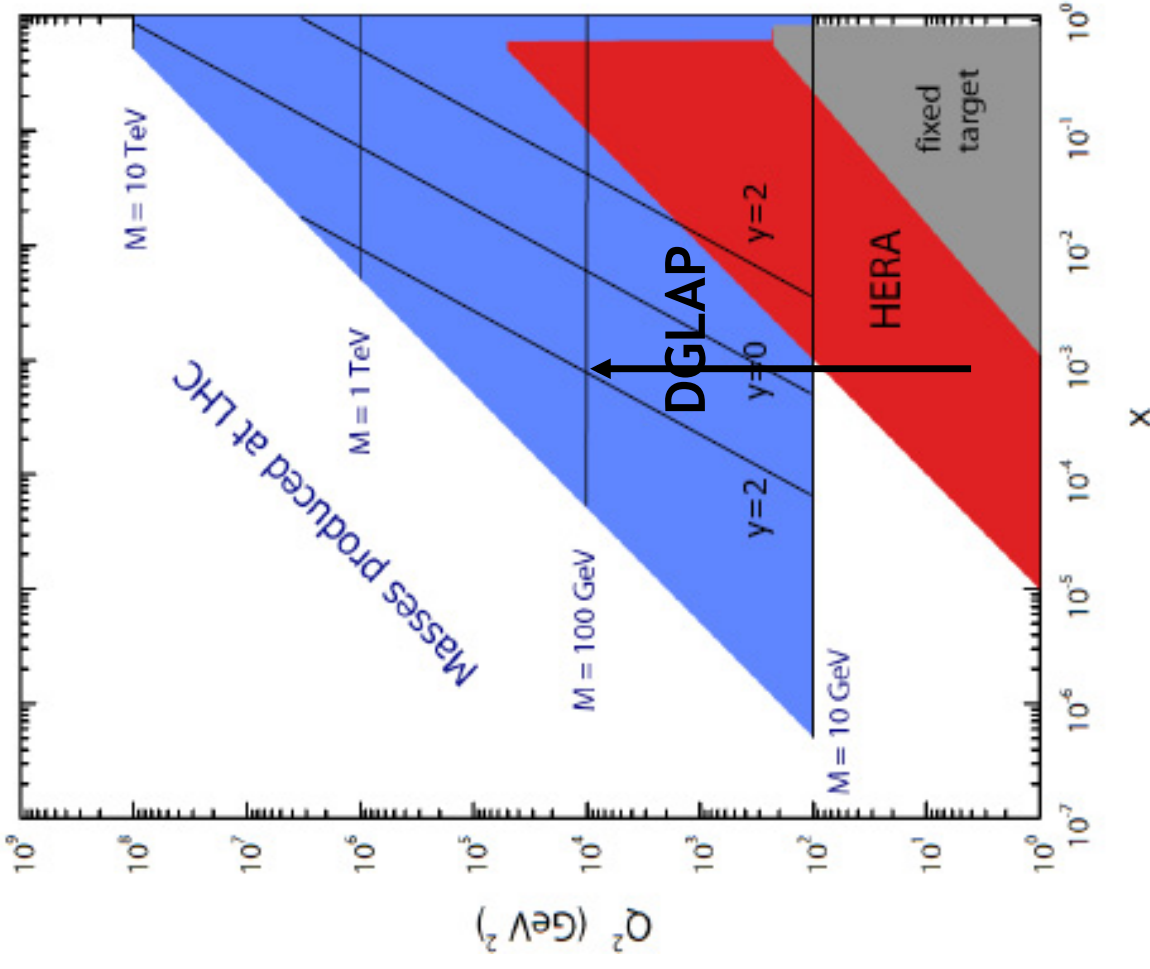

e.g. pp dijets at central rapidity: $x_1=x_2=2p_t / \sqrt{s}$

Currently Approved Future of High Energy DIS



How Could ep be Done using LHC?

... whilst allowing simultaneous pp running...

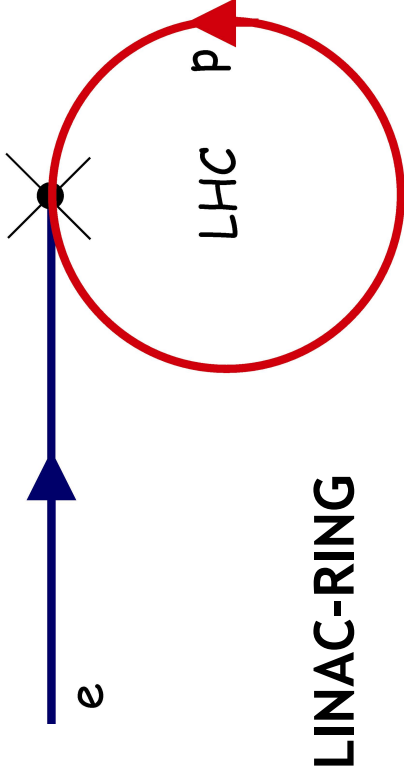
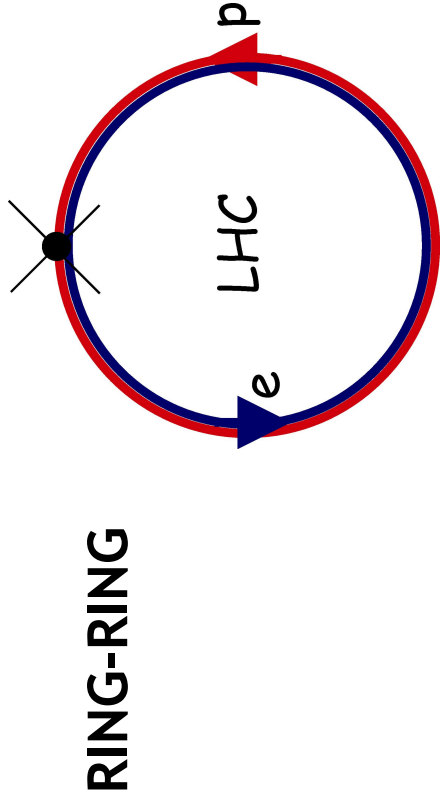

- First considered (as LEPxLHC) in 1984 ECFA workshop
- Main advantage: high peak lumi obtainable ($\sim 2 \cdot 10^{33} \text{ cm}^{-2} \text{ s}^{-1}$)
- Main difficulties: building round existing LHC, e beam energy (60GeV?) and lifetime limited by synchrotron radiation

- Previously considered as 'QCD explorer' (also THERA)
- Main advantages: low interference with LHC, high E_e ($\rightarrow 150 \text{ GeV}$) and lepton polarisation, LC relation
- Main difficulties: lower luminosity $< 10^{33} \text{ cm}^{-2} \text{ s}^{-1}$? at reasonable power, no previous experience exists

Accelerator Design

Multi-Lab Involvement Novosibirsk, BNL, CERN, Cockcroft, Cornell, DESY, EPFL Lausanne, Jlab, KEK, Liverpool, SLAC, TAC Turkey, NTFU Norway, INFN ...

Design constraint: power consumption < 100 MW

→ $E_e = 60$ GeV in ring-ring mode

Ring-Ring Design

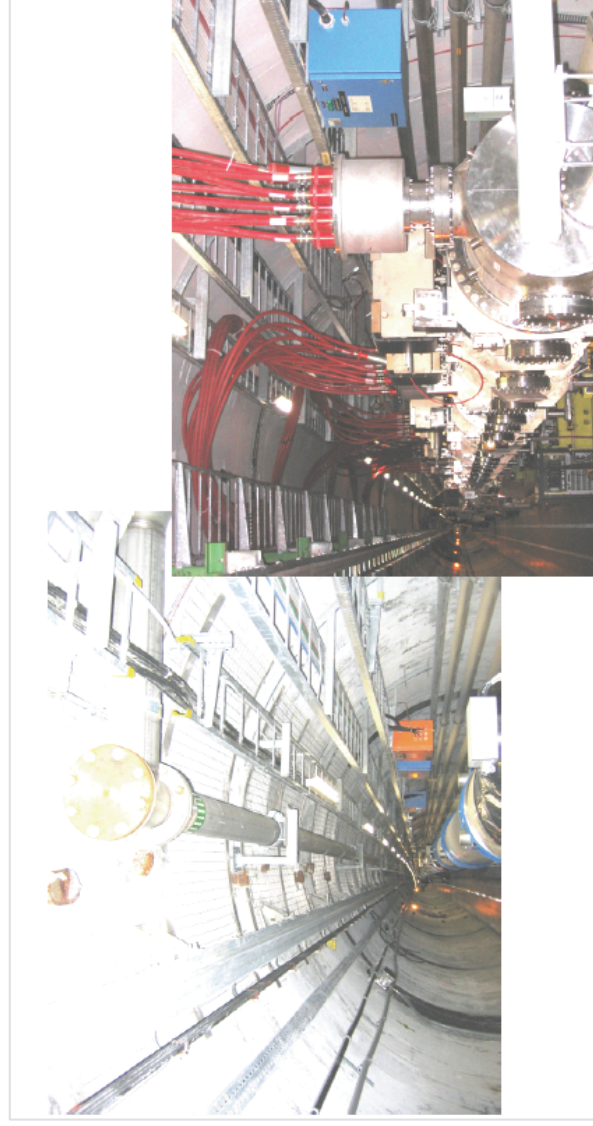

Installation 1m above LHC and 60cm inside

By-passes of existing experiments containing RF

Challenging, but no show stopper yet

e Ring- p/A Ring

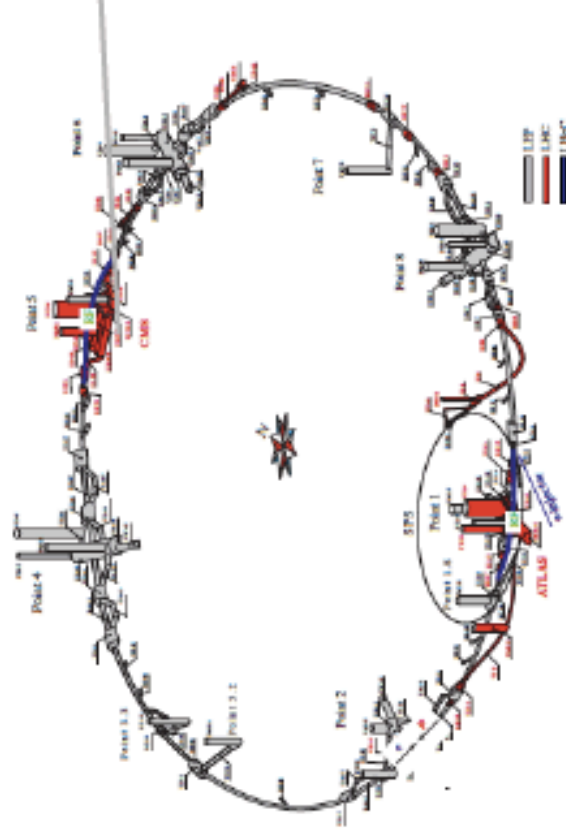
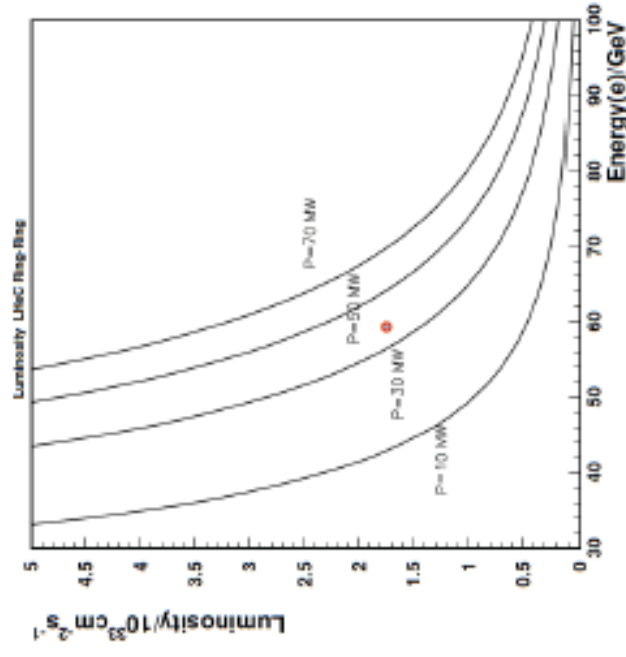
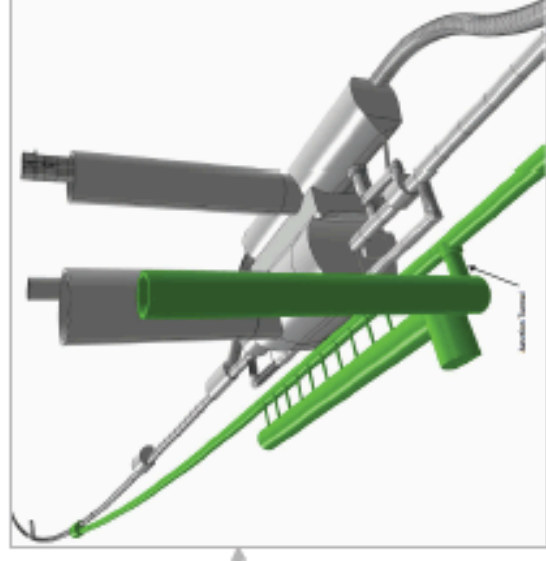

Figure 1: Schematic Layout of the LHC (grey/red) with the bypasses of CMS and ATLAS for the ring electron beam (blue) in the RR version. The e injector is a 10 GeV superconducting linac in triple racetrack configuration which is considered to reach the ring via the bypass around ATLAS.



Magnets for Electron Ring (CERN, Novosibirsk)

3080 bending dipole magnets

5m long
(35cm)² transverse
0.013 - 0.08 T
~ 200 kg / m

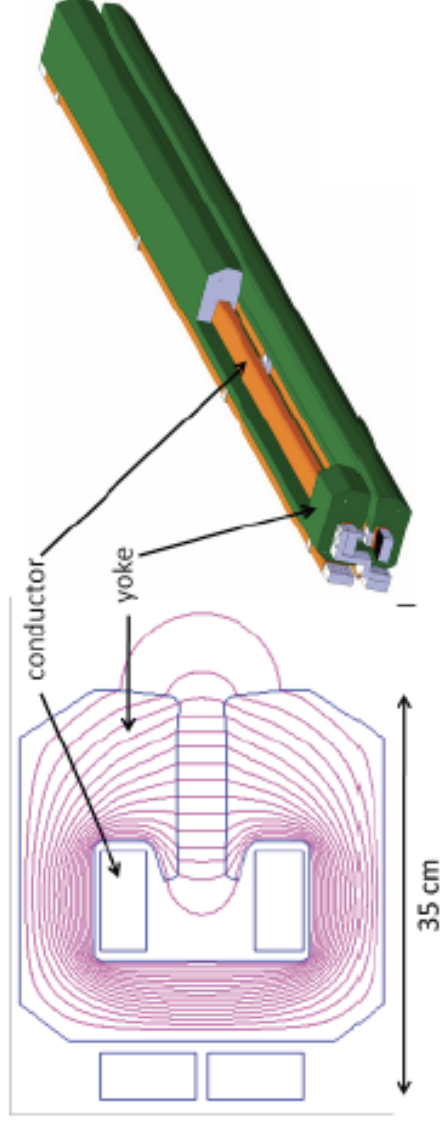

Fig. 2. Field lines and artistic view of a LHeC arc dipole.

First prototypes
functions to spec.



866 arc quadrupole magnets

[1.2m long]

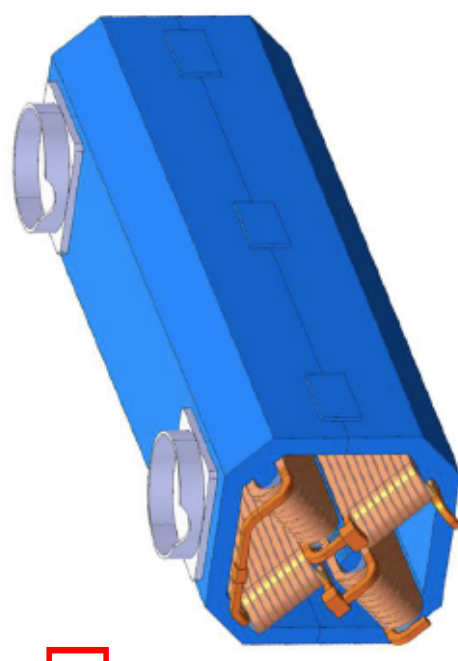
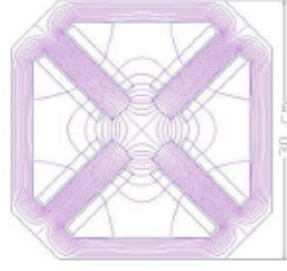

Accelerator Design in Linac-Ring Configuration

4 separate designs for 60 GeV electron beam (CERN, Jlab, BNL)

- 500 MeV injection
- Two 10 GeV linacs,
- 3 returns
- Energy recovers in same structures (94%)?

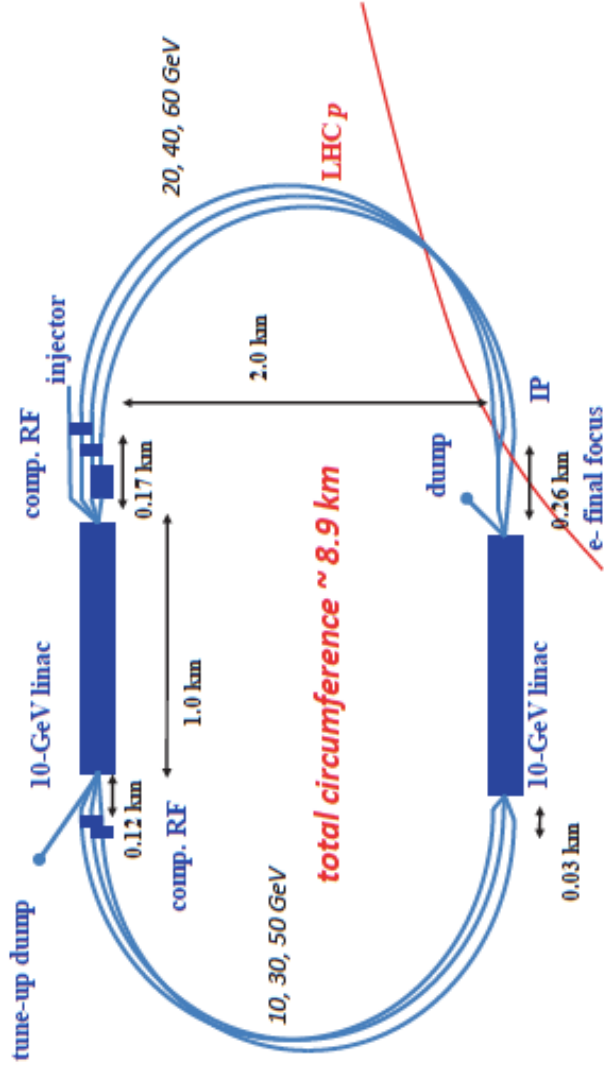

More ambitious:
Pulsed single
140 GeV Linac
31.5 MV/m (ILC)

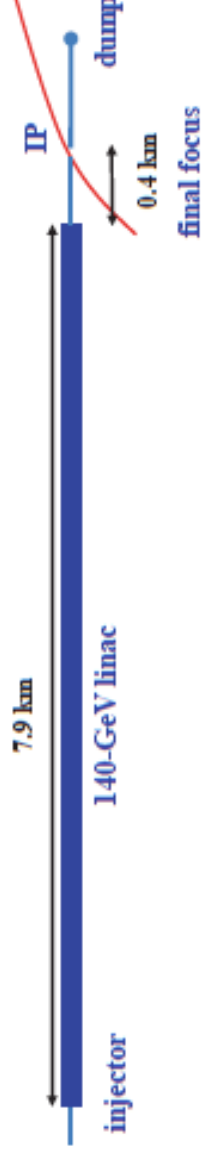



TUPC017

Civil Engineering Studies for Major Projects after LHC

Design Parameter Summary

RR= Ring - Ring

LR =Linac -Ring

electron beam	RR	LR	LR
e- energy at IP[GeV]	60	60	140
luminosity [$10^{32} \text{ cm}^{-2}\text{s}^{-1}$]	17	10	0.44
polarization [%]	40	90	90
bunch population [10^9]	26	2.0	1.6
e- bunch length [mm]	10	0.3	0.3
bunch interval [ns]	25	50	50
transv. emit. $\gamma\epsilon_{x,y}$ [mm]	0.58, 0.29	0.05	0.1
rms IP beam size $\sigma_{x,y}$ [μm]	30, 16	7	7
e- IP beta funct. $\beta^*_{x,y}$ [m]	0.18, 0.10	0.12	0.14
full crossing angle [mrad]	0.93	0	0
geometric reduction H_{hg}	0.77	0.91	0.94
repetition rate [Hz]	N/A	N/A	10
beam pulse length [ms]	N/A	N/A	5
ER efficiency	N/A	94%	N/A
average current [mA]	131	6.6	5.4
tot. wall plug power[MW]	100	100	100

proton beam	RR	LR
bunch pop. [10^{11}]	1.7	1.7
tr.emit. $\gamma\epsilon_{x,y}$ [μm]	3.75	3.75
spot size $\sigma_{x,y}$ [μm]	30, 16	7
$\beta^*_{x,y}$ [m]	1.8,0.5	0.1
bunch spacing [ns]	25	25

Include deuterons
(new) and lead (exists)

10 fb⁻¹ per year
looks possible

Detector Acceptance Requirements

Access to $Q^2=1 \text{ GeV}^2$ in ep mode for all $x > 5 \times 10^{-7}$ requires scattered electron acceptance to 179°

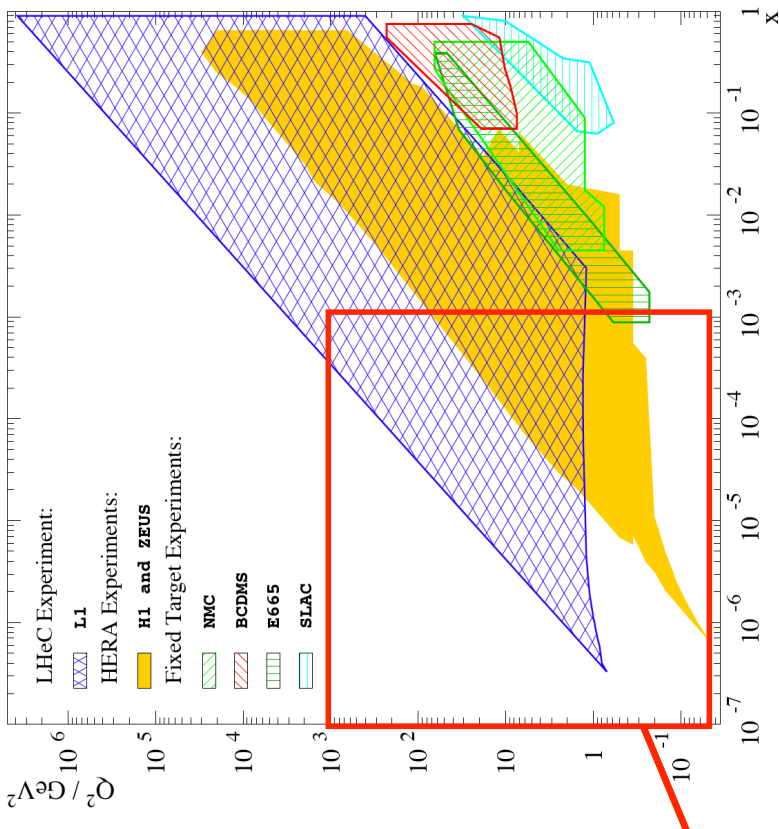
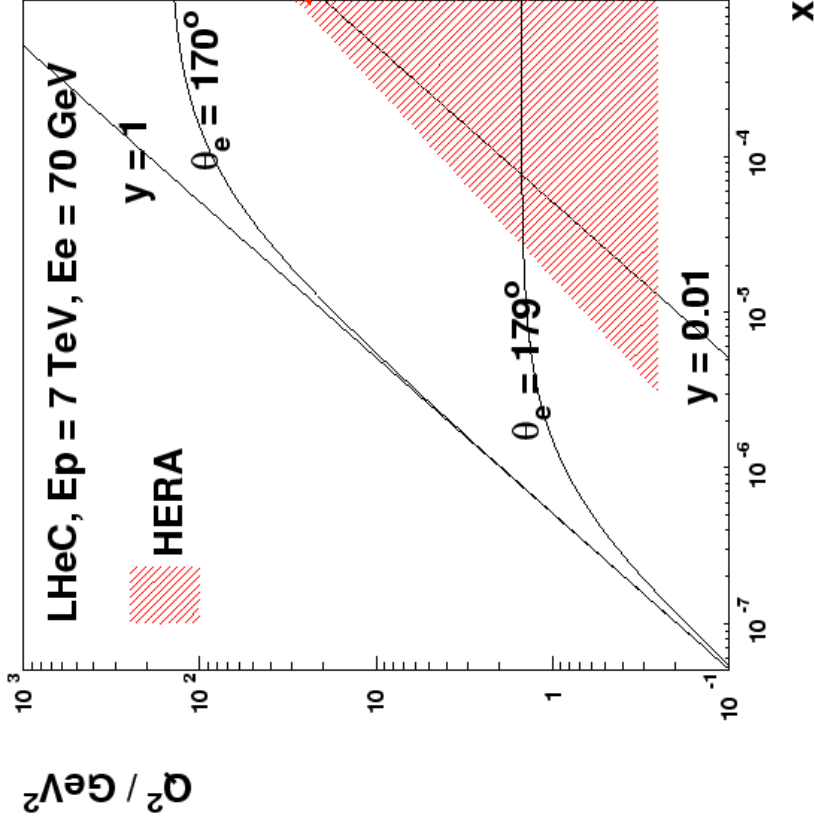

Similarly, need 1° acceptance in outgoing proton direction to contain hadrons at high x (essential for good kinematic reconstruction)

Experimental Precision Aims

Requirements to reach a per-mille α_s (c.f. 1-2% now) ...

The new collider ...

- should be ~100 times more luminous than HERA

The new detector

- should be at least 2 times better than H1 / ZEUS

	LHeC	HERA
Lumi [$\text{cm}^{-2}\text{s}^{-1}$]	10^{33}	$1-5 \cdot 10^{31}$
Acceptance [°]	1-179	7-177
Tracking to	0.1 mrad	0.2-1 mrad
EM calorimetry to	0.1%	0.2-0.5%
Hadronic calorimetry	0.5%	1-2%
Luminosity	0.5%	1%

Simulated 'pseudo-data' for F_2 , F_L , F_2^D ...produced on this basis

Detector Overview

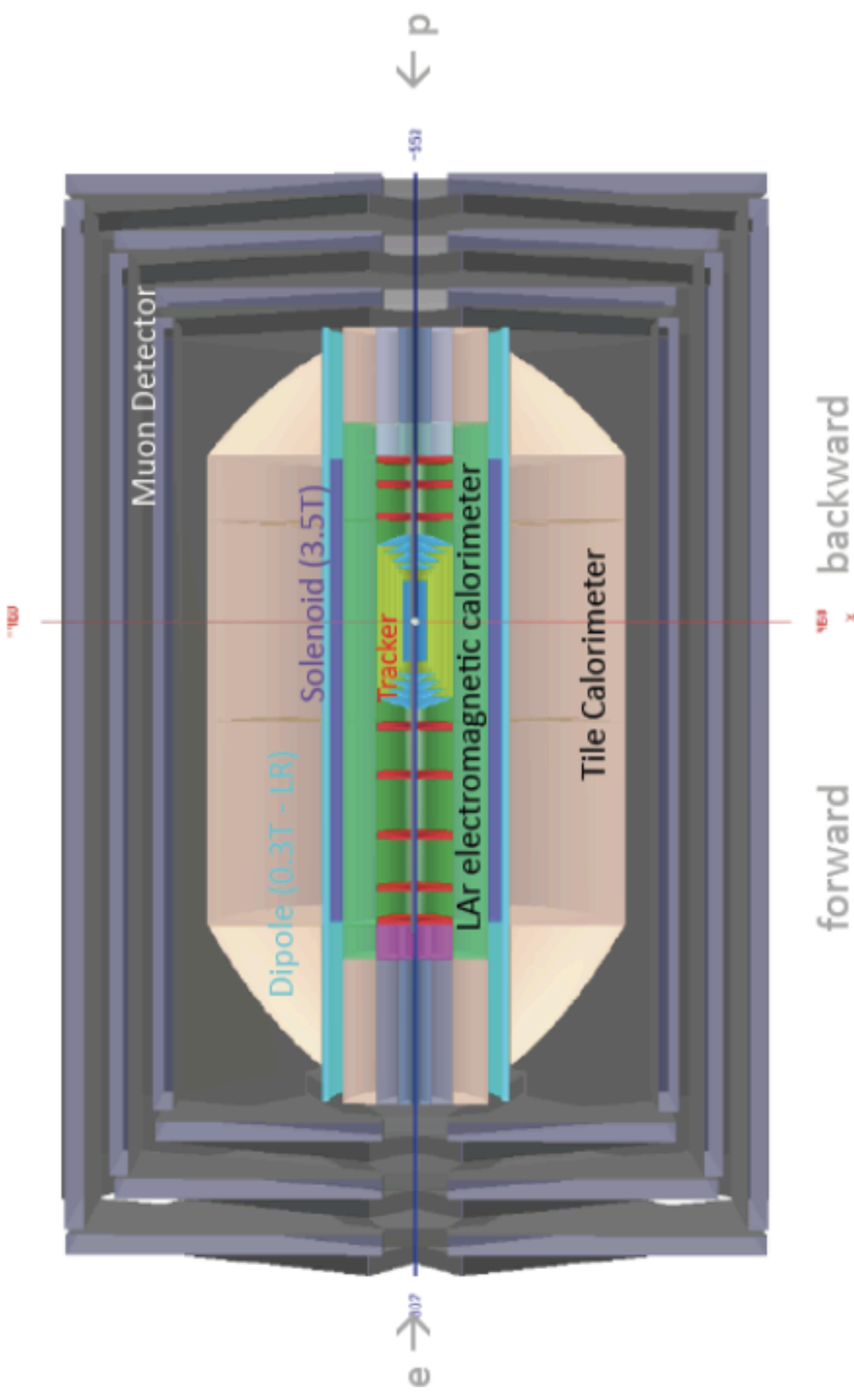

- Present dimensions: $L \times D = 14 \times 9 \text{ m}^2$ [CMS $21 \times 15 \text{ m}^2$, ATLAS $45 \times 25 \text{ m}^2$]
- Taggers at -62 m (e), 100 m (Y,LR), -22.4 m (Y,RR), $+100 \text{ m}$ (n), $+420 \text{ m}$ (p)
- General point: Lumi versus acceptance!

Calorimeters

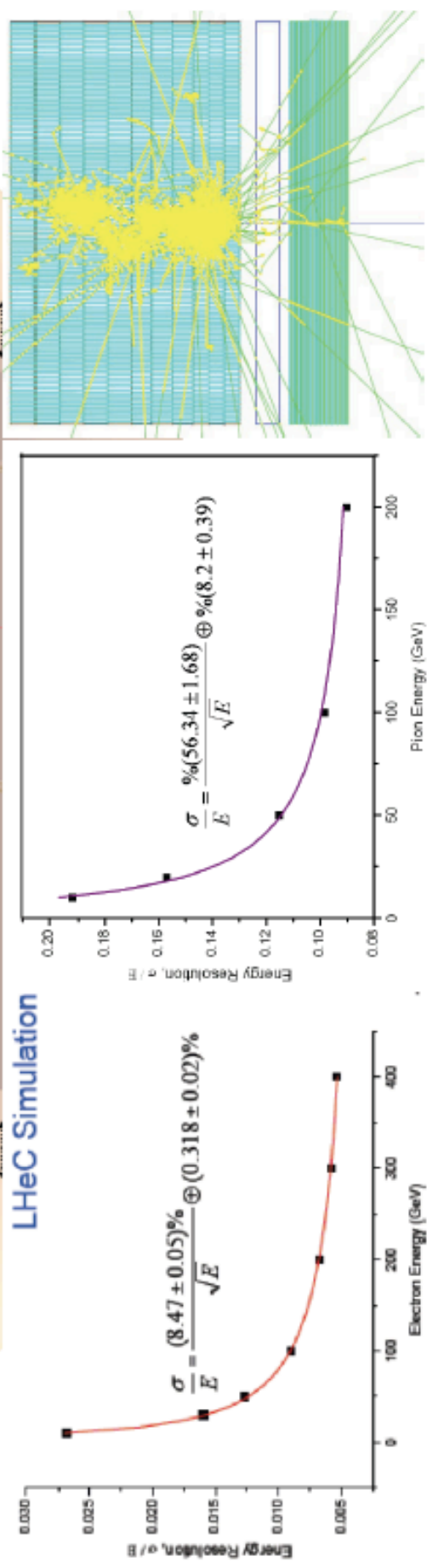
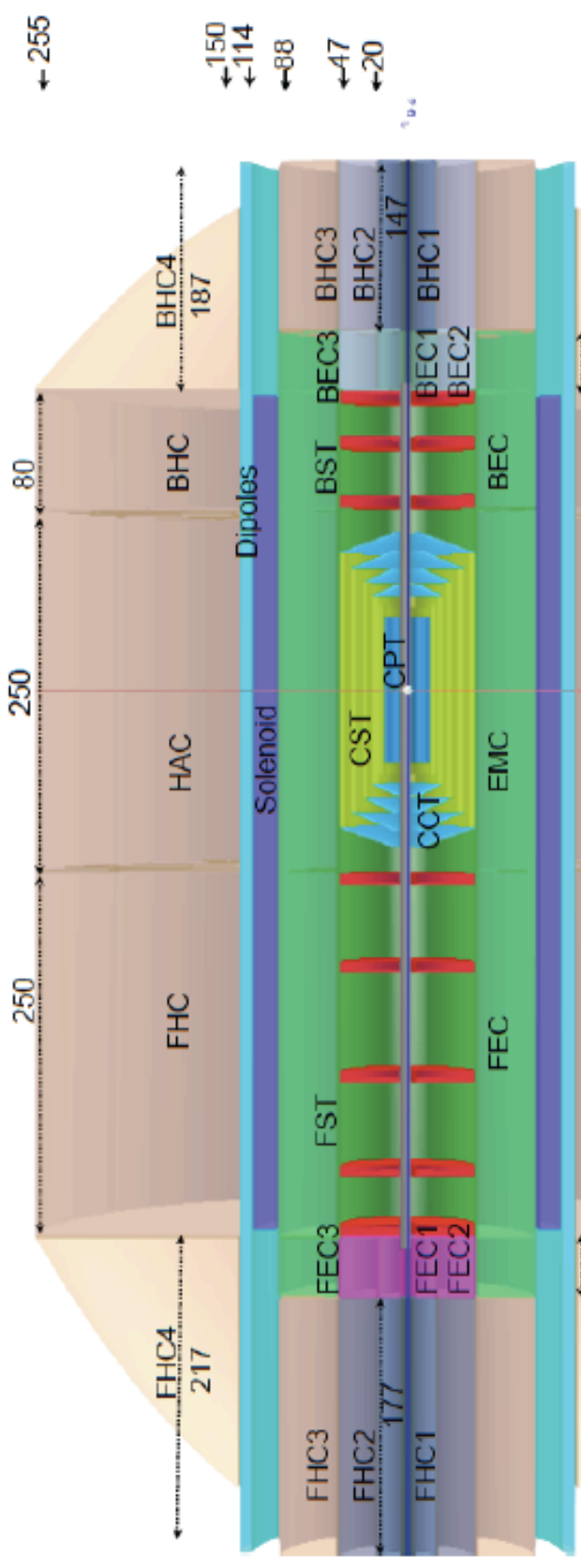

Liquid Argon / Tile technologies under study

Tracking Region

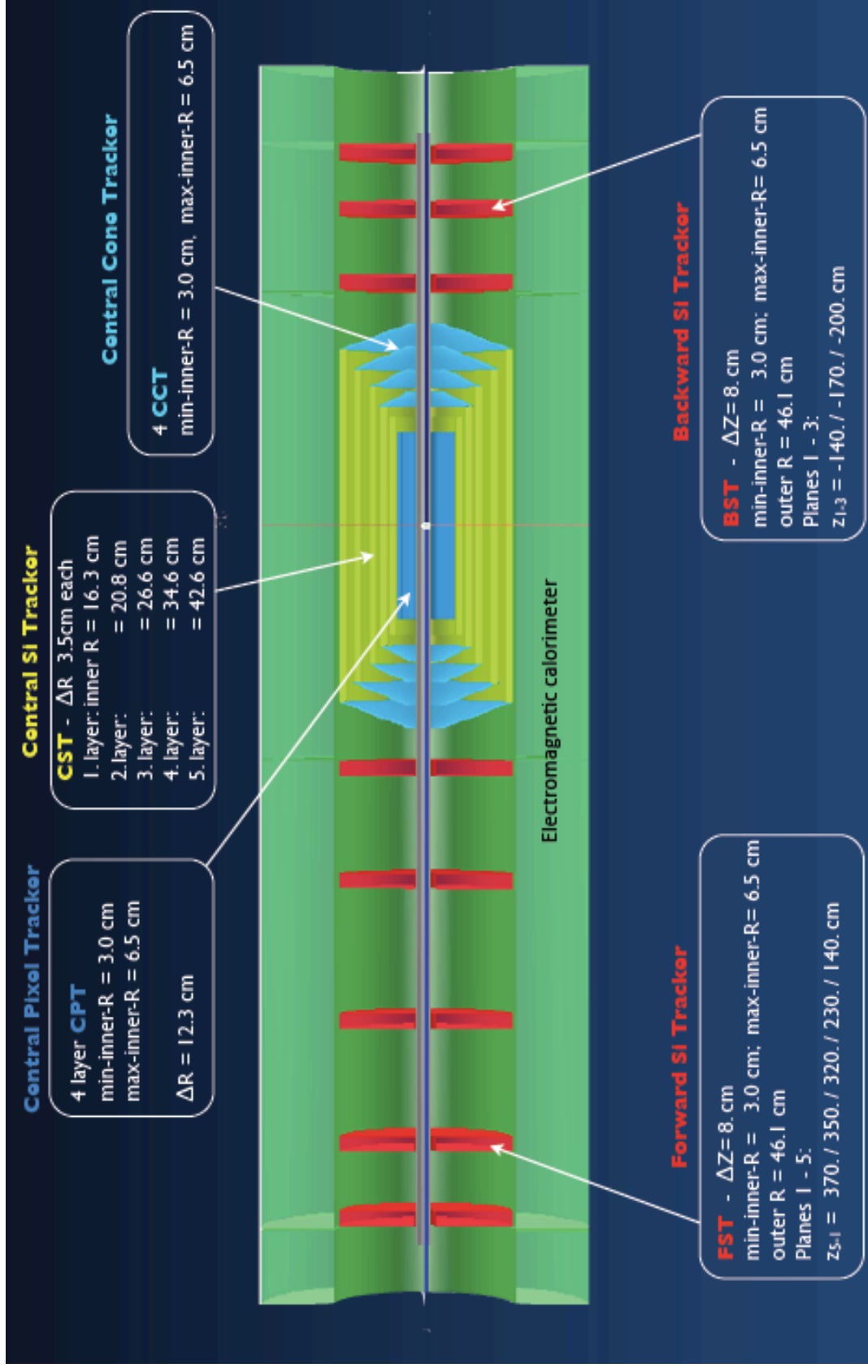

- Full angular coverage, long tracking region $\rightarrow 1^\circ$ acceptance
- Technologies under discussion (lots of ideas!)

A GEANT4 Simulated Low x Event

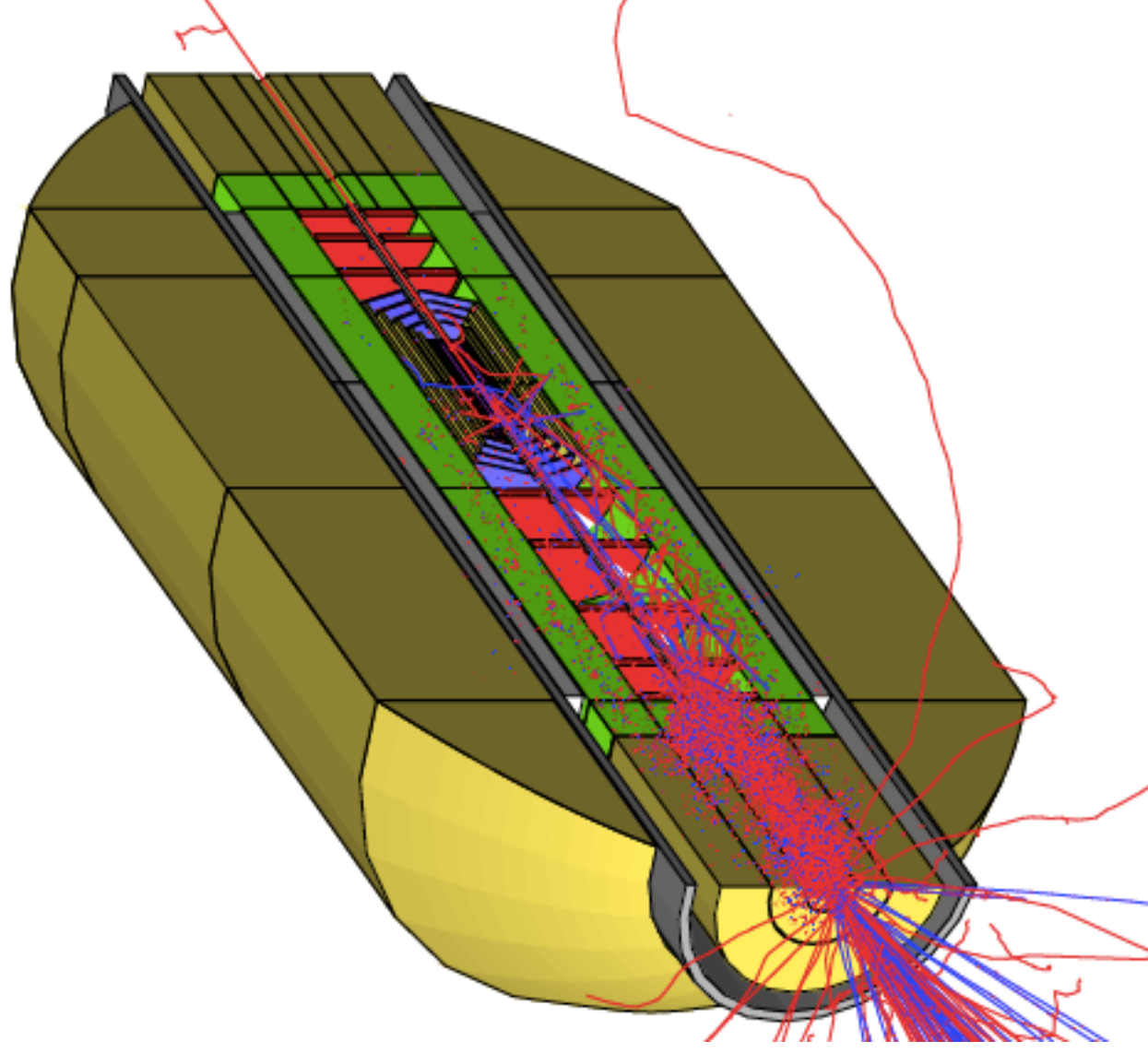

Searches For New Physics

- The (pp) LHC has much better discovery potential than the LHeC (unless electron beam energy can increase to > 500 GeV)

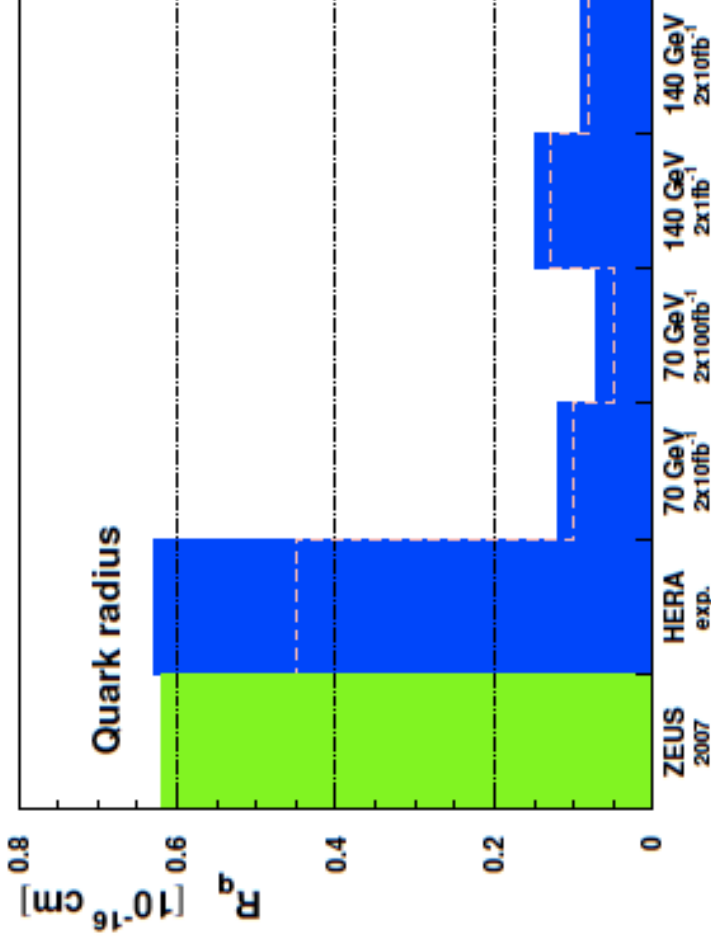

e.g. Expected quark compositeness limits below 10^{-19} m at LHeC

... big improvement on HERA, but already beaten by LHC in its first year

- However, LHeC is competitive with LHC in cases where initial state lepton is an advantage and offers cleaner final states
- Combined LHC / LHeC info can confirm and clarify new physics

Lepton-quark Resonances

- Leptoquarks appear in many extensions to SM... (eg R-parity violating SUSY) ... explain apparent symmetry between lepton and quark sectors.

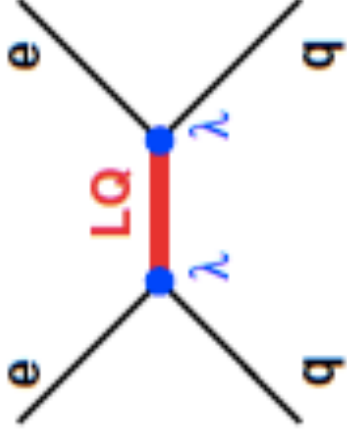

Yukawa coupling, λ

- Scalar or Vector color triplet bosons Carrying L, B and fractional Q, complex spectroscopy?

- (Mostly) pair produced in pp, single production in ep.

- LHeC discovery potential for masses $< 1.0 - 1.5$ TeV for 10 fb^{-1} - Comparable to LHC, but cleaner!

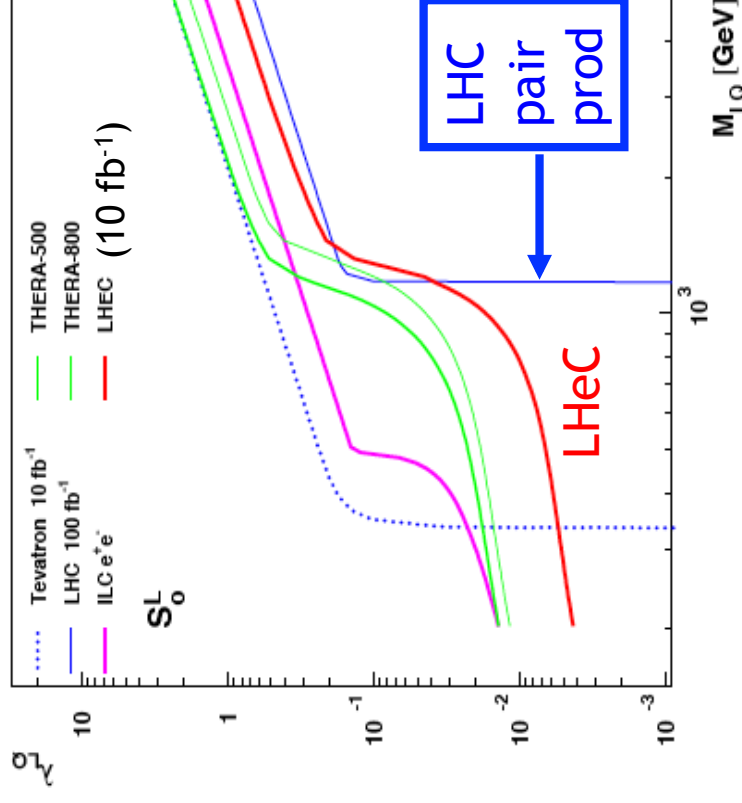

Determining Leptoquark Quantum Numbers

- Single production gives access to quantum numbers:
- fermion number (below)
- spin (decay angular distributions)
- chiral couplings (beam lepton polarisation asymmetry)

- Fermion number F from asymmetry in e^+e^- cross sections
- Much cleaner accessible in DIS

$$A = \frac{\sigma_{e^-} - \sigma_{e^+}}{\sigma_{e^-} + \sigma_{e^+}} \begin{cases} > 0 \text{ for } F=2 \\ < 0 \text{ for } F=0 \end{cases}$$

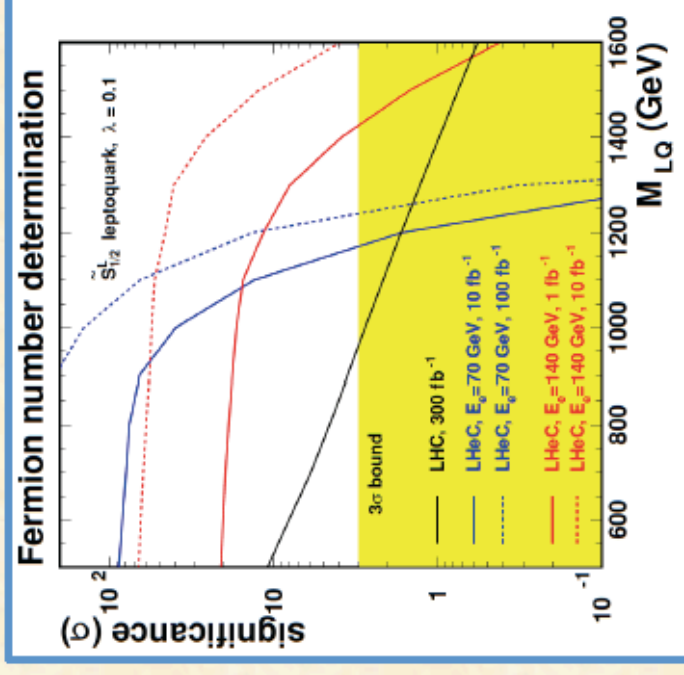
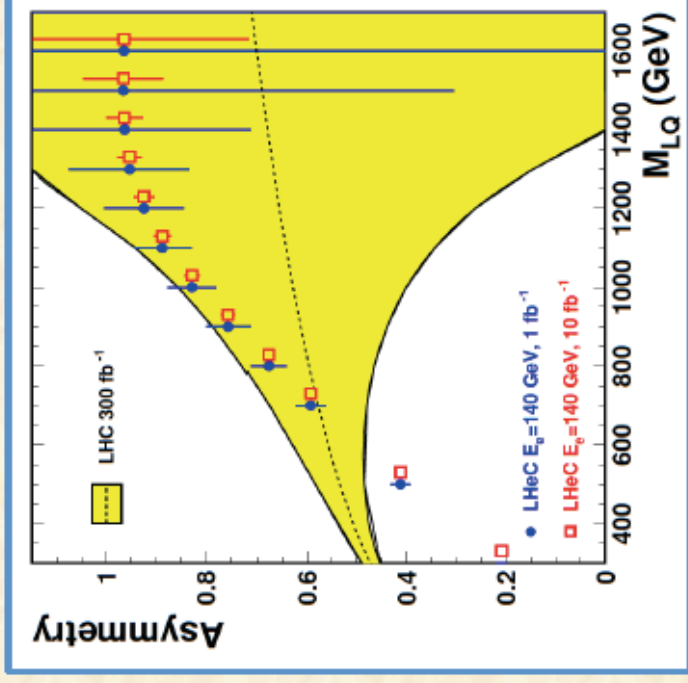
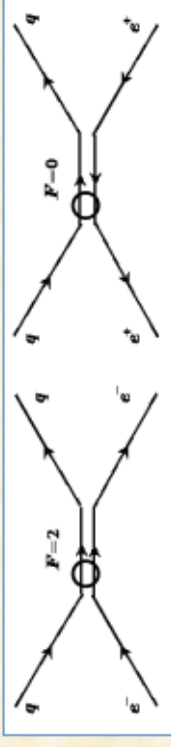

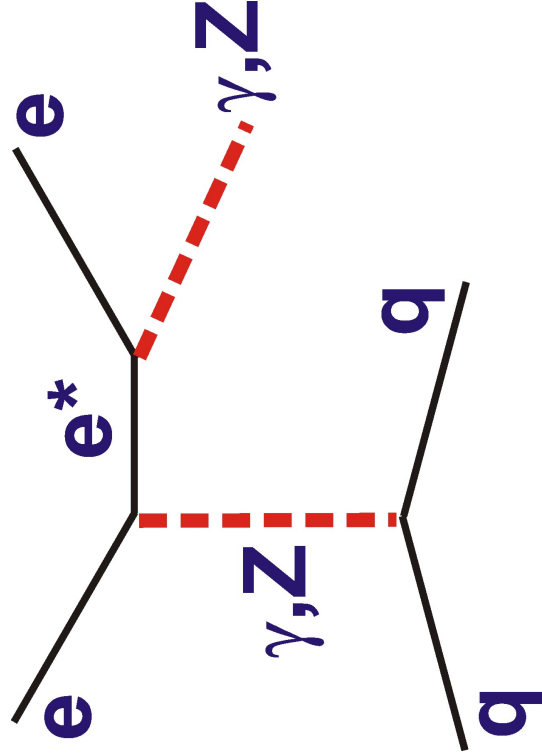
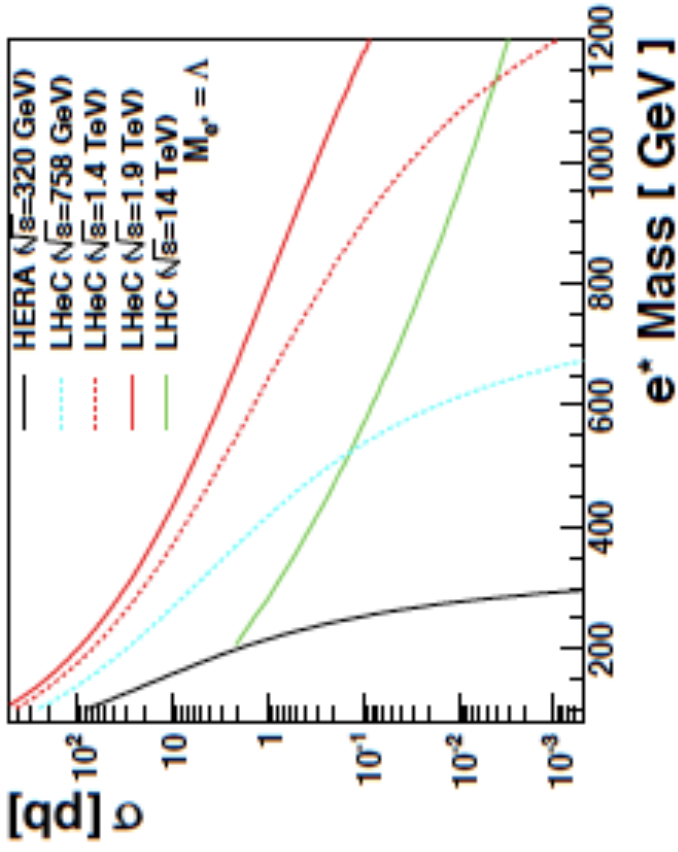

Excited Leptons

LHeC sensitivity with 1-10 fb⁻¹ competitive with LHC

Similarly, excited neutrinos

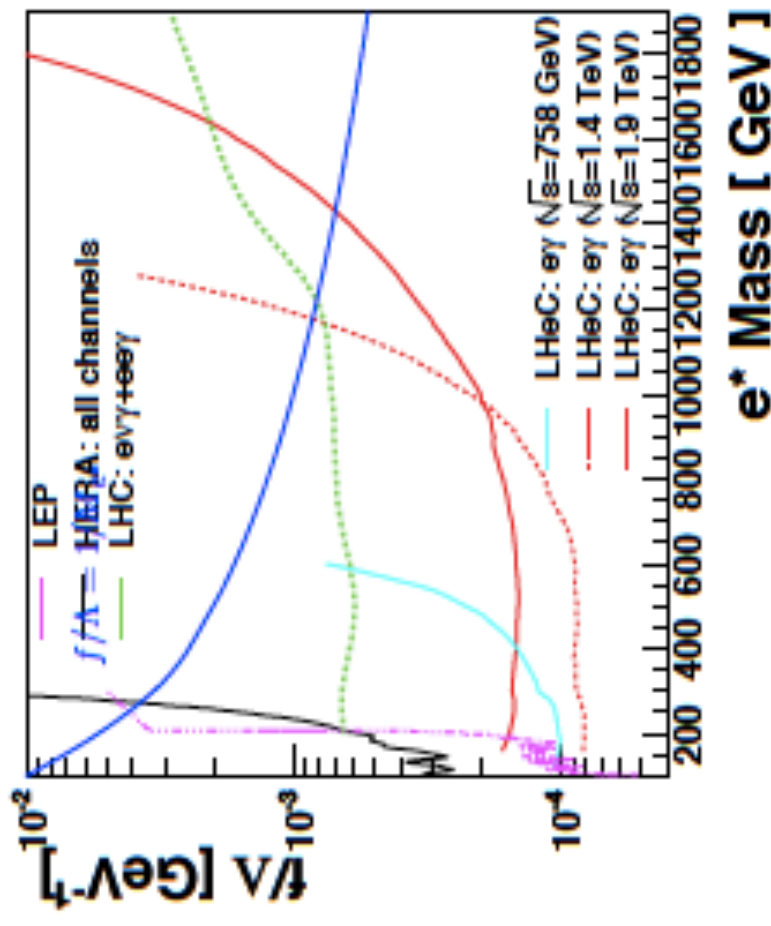

Anomalous WW \rightarrow H and H \rightarrow bb $\bar{\bar{b}}$ Couplings?

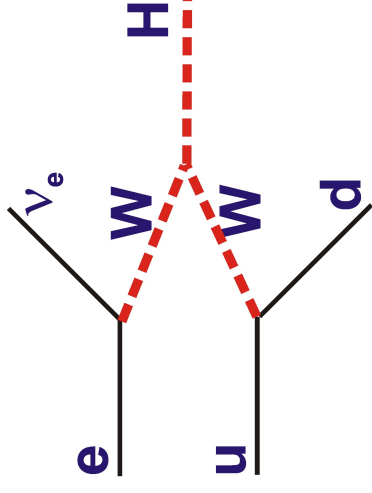
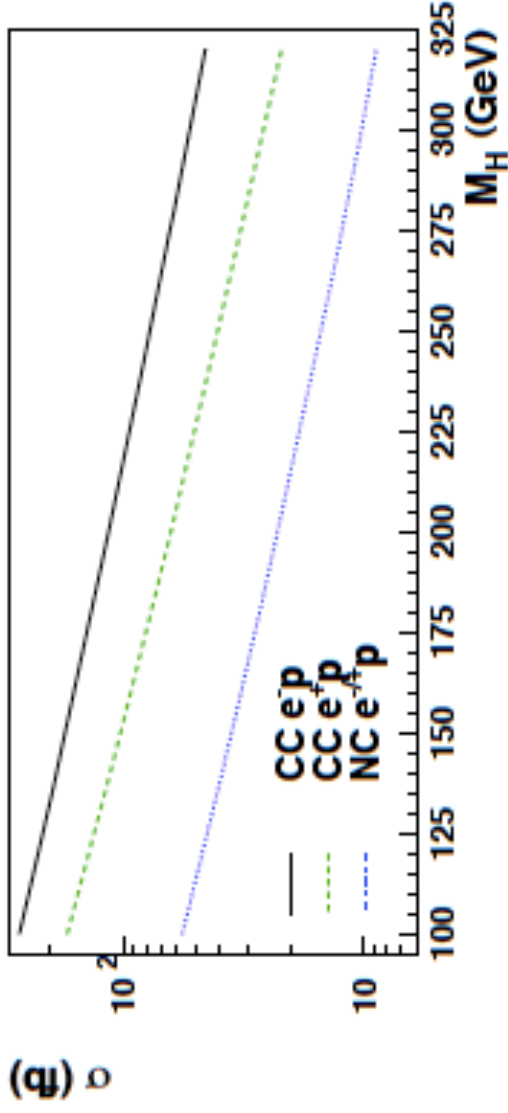

Sizeable CC (WW) x-sec
 \rightarrow Few 1000 SM
 events / yr before cuts

\rightarrow Clean signal: H + j + p_t^{miss}

First study with 2 b-tags
 Backgrounds (jets in NC, CC,
 top) suppressed with cuts on
 jet multiplicity, b-tags, event
 kinematics, missing p_t
 \sim 100 Standard Model

events / year (10 fb^{-1}) after cuts?

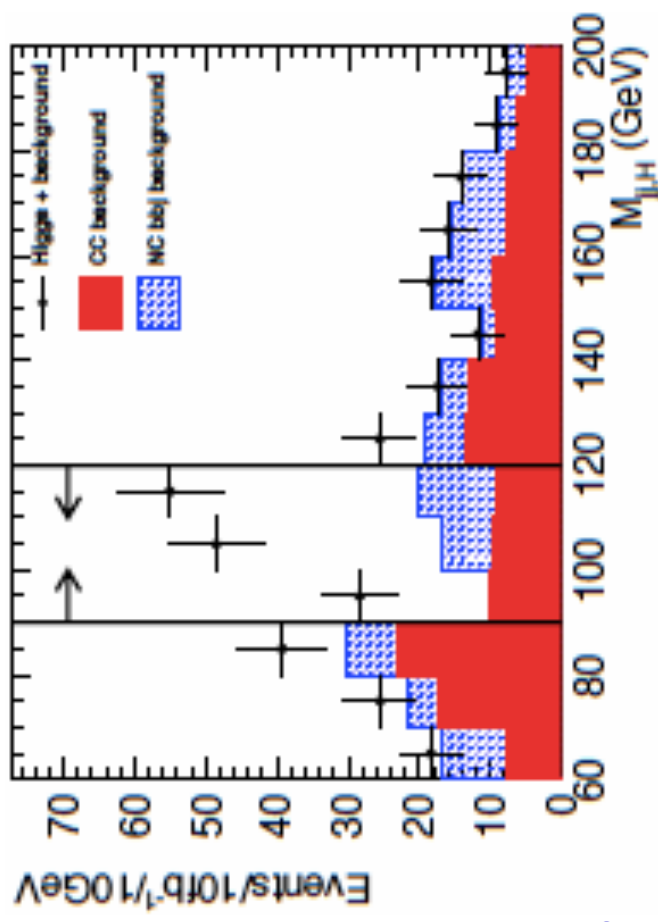

Complementarity between LHC and LHeC

Contact interaction term introduced in LHC pseudo-data for high mass Drell-Yan

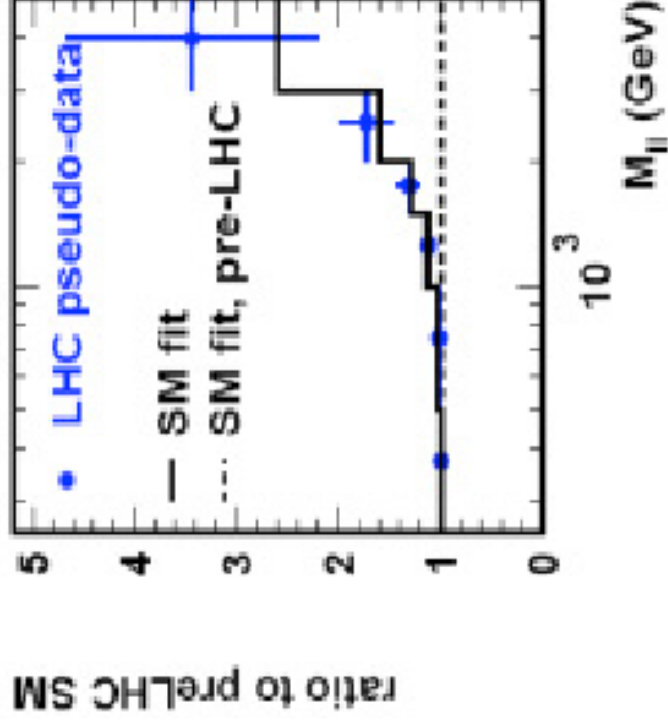
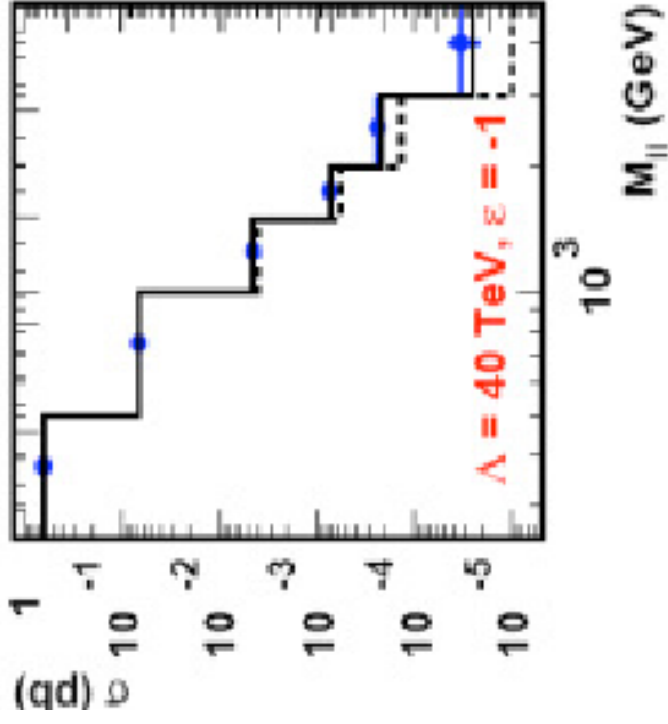
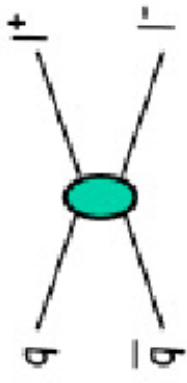

- Even if new physics looks rather different from SM, wide range of high x BSM effects can be accommodated in DGLAP fits due to poor current high x PDF constraints
- Better high x precision at high lumi LHeC could disentangle ...

LHeC Impact on Parton Densities

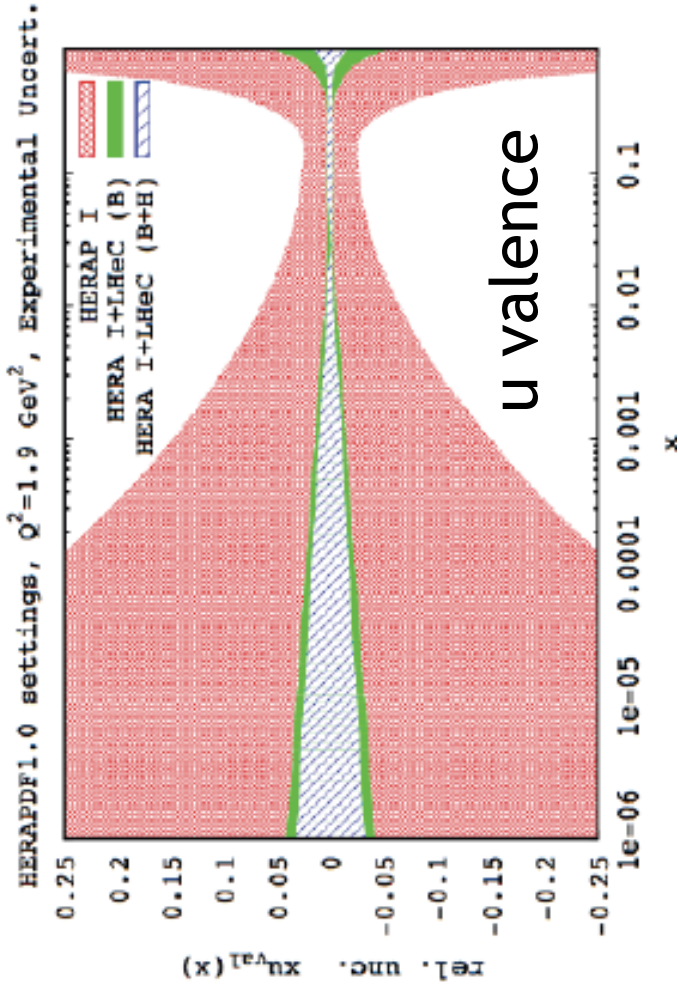
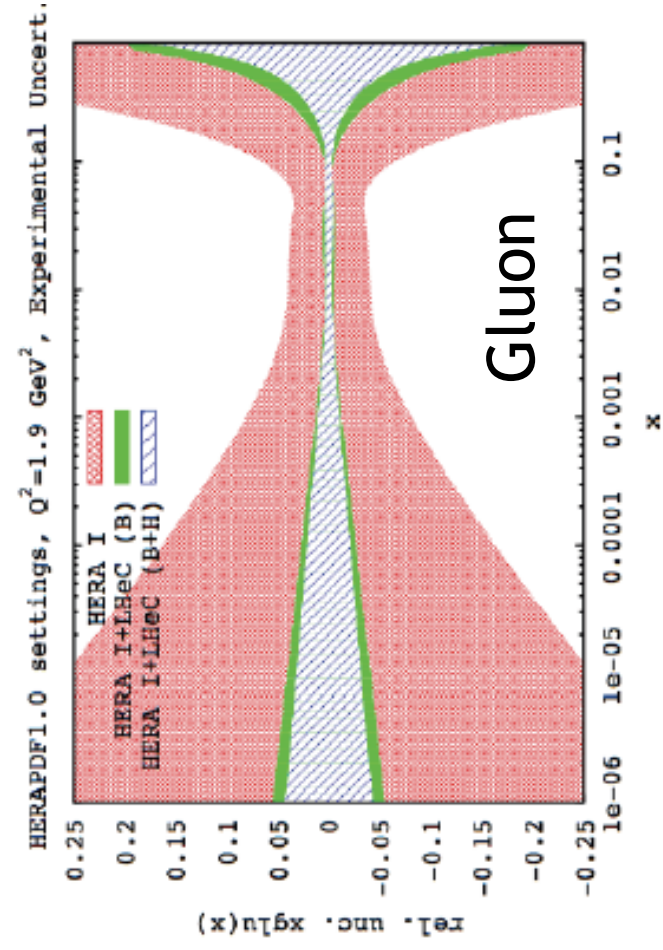

Full NC/CC sim (with systs giving per mille α_s) & NLO DGLAP fit using HERA technology...

... big impact for both low x (kinematic range) and high x (luminosity)

... full flavour decomposition possible

Cross Sections and Rates for Heavy Flavours

LHeC total cross sections (MC simulated)

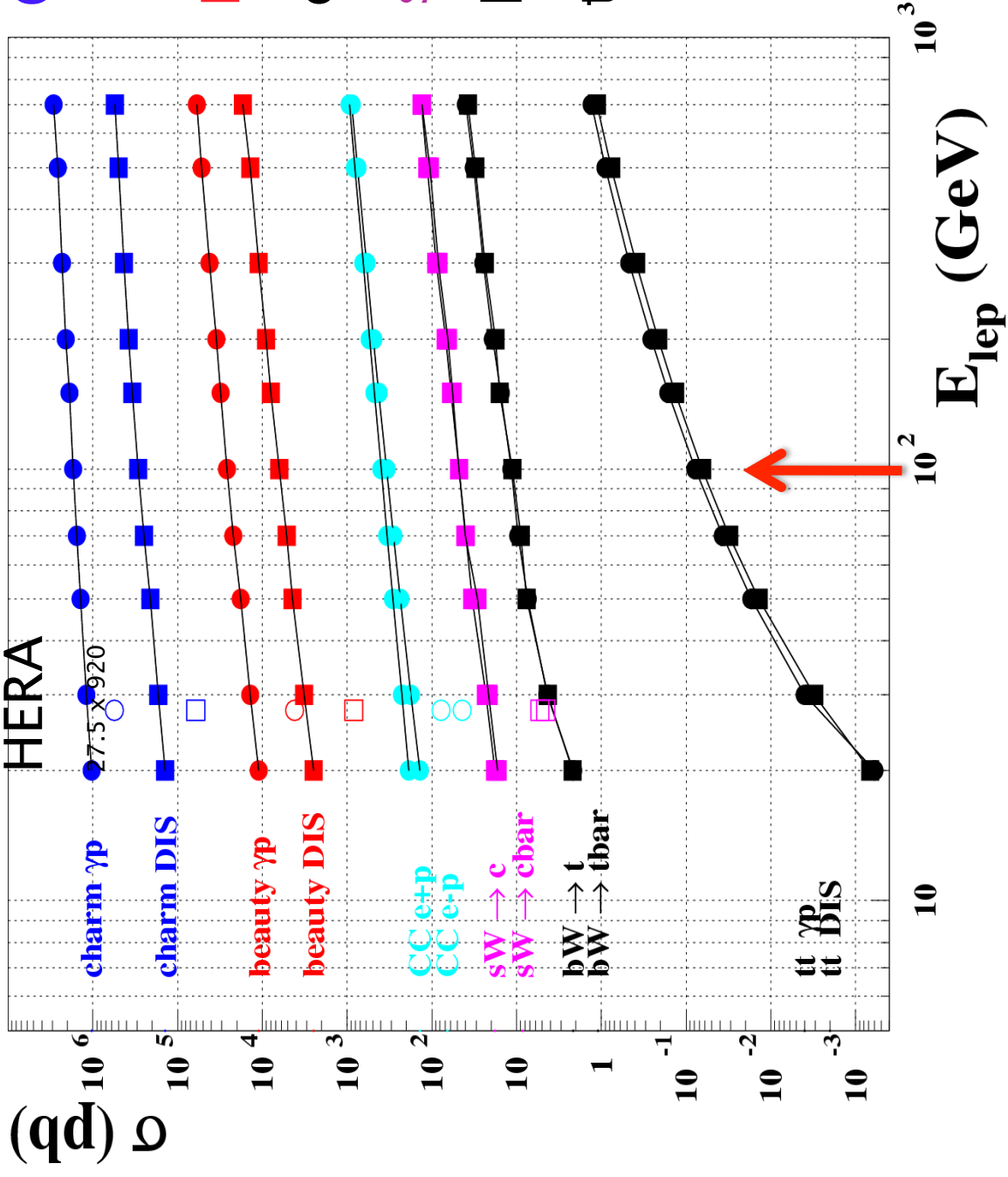

Charm [10^{10} / 10 fb^{-1}]

Beauty [10^8 / 10 fb^{-1}]

CC

$sW \rightarrow c$ [$4 \cdot 10^5$ / 10 fb^{-1}]

$bW \rightarrow t$ [10^5 / 10 fb^{-1}]

$ttbar$ [10^3 / 10 fb^{-1}]

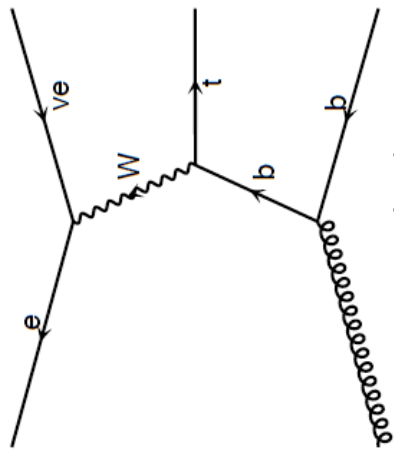

c.f. luminosity of $\sim 10 \text{ fb}^{-1}$ per year ...

Flavour Decomposition

Precision c, b measurements
 (modern Si trackers, beam spot $15 * 35 \mu\text{m}^2$, increased HF rates at higher scales).
Systematics at 10% level

→ beauty is a low x observable!
 → s, sbar from charged current
 → Similarly $Wb \rightarrow t$

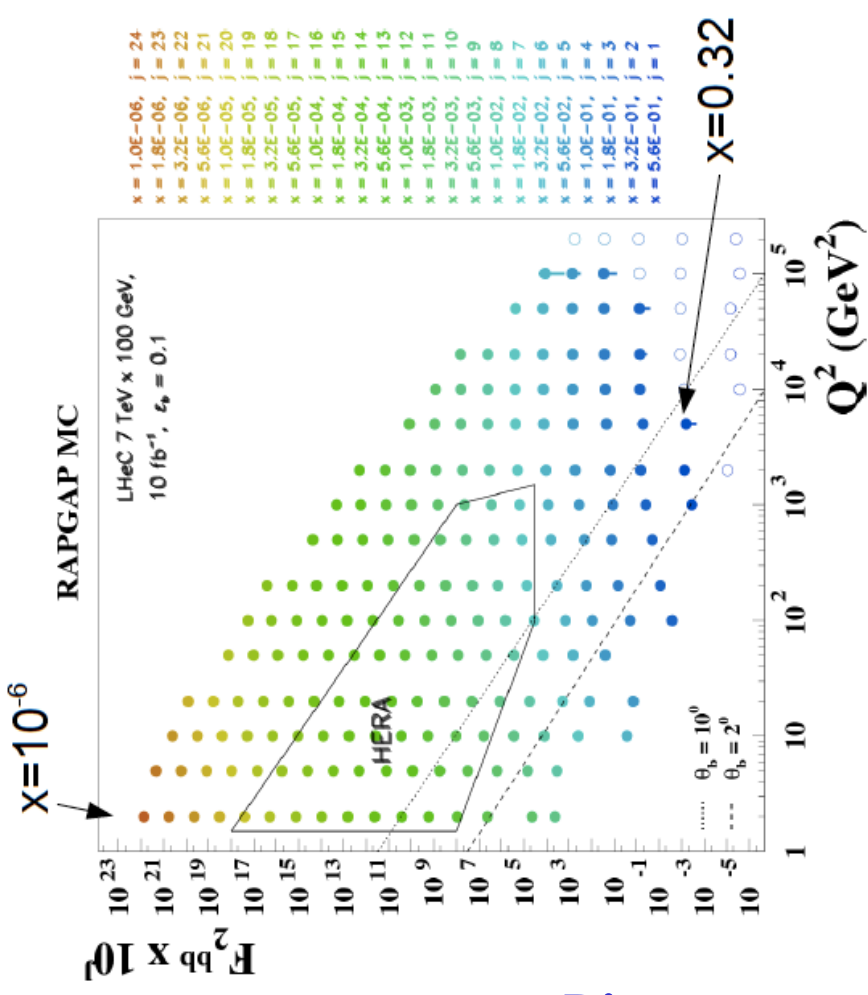
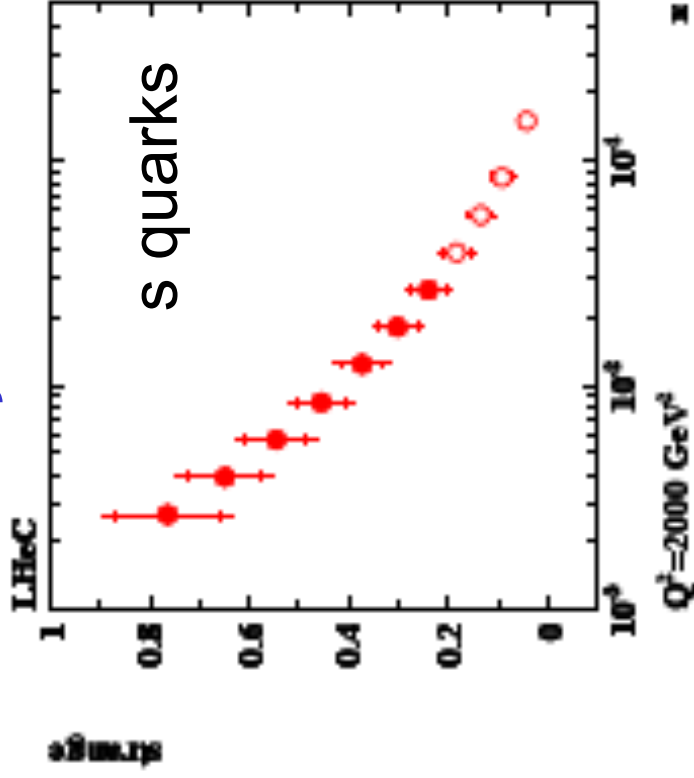

- LHeC 10° acceptance
- LHeC 1° acceptance

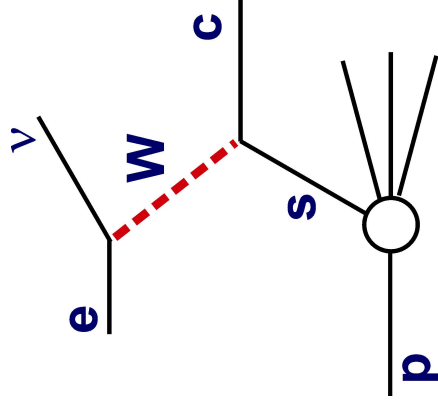

(Assumes 1 fb^{-1} and
 - 50% beauty, 10% charm efficiency
 - 1% uds \rightarrow c mistag probability.
 - 10% c \rightarrow b mistag)

PDFs & EW Couplings

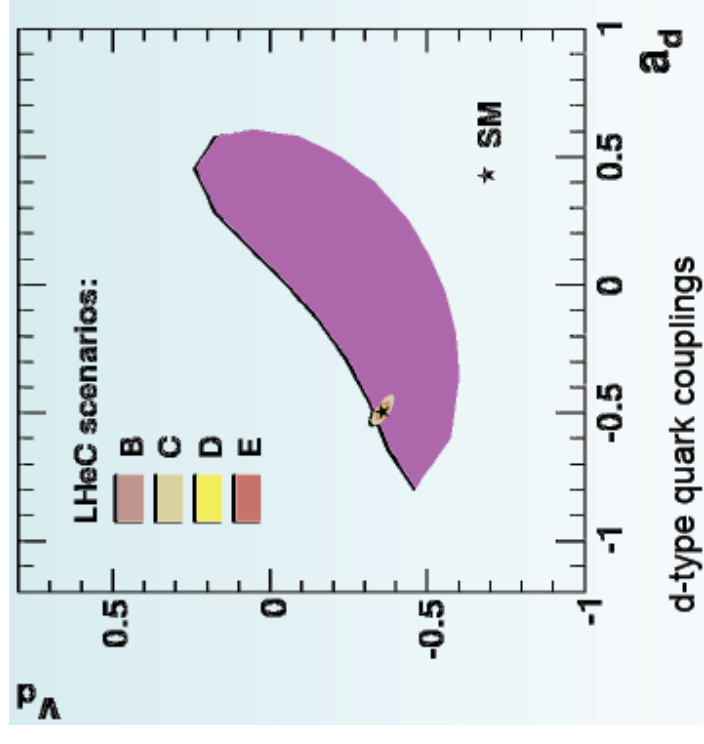
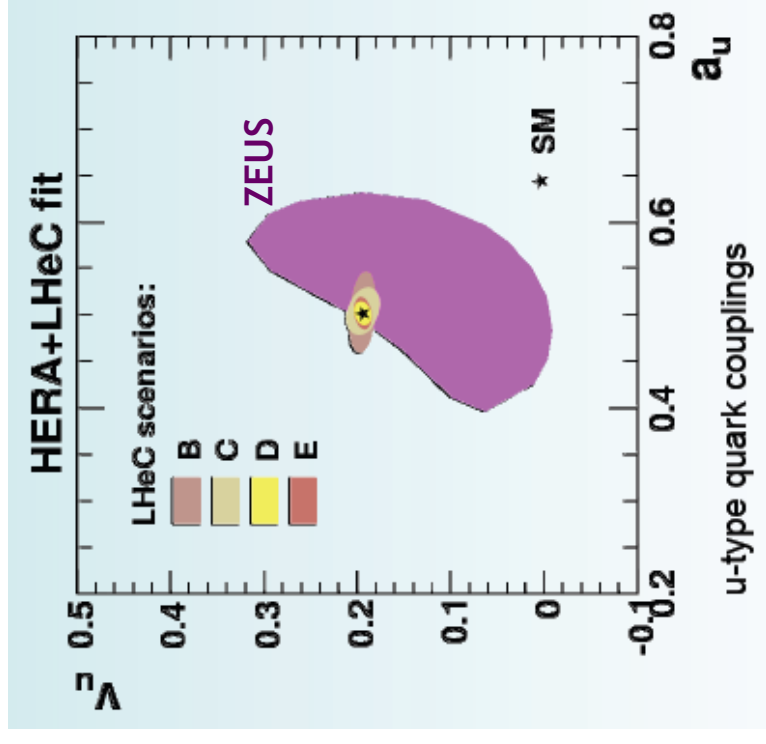
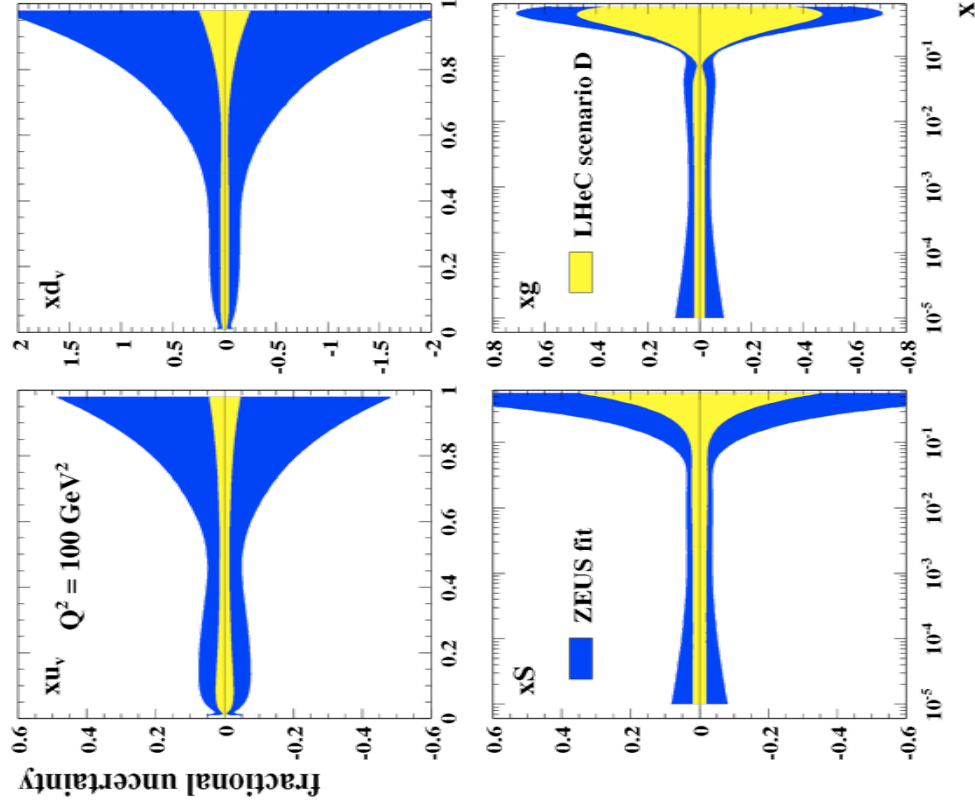

Using ZEUS fitting code, HERA + LHeC data ... EW couplings free
 $E_e = 100 \text{ GeV}$, $L = 10+5 \text{ fb}^{-1}$, $P = +/\text{-} 0.9$
 Also: Weak mixing angle at TeV scales

Inclusive Jets & QCD Dynamics

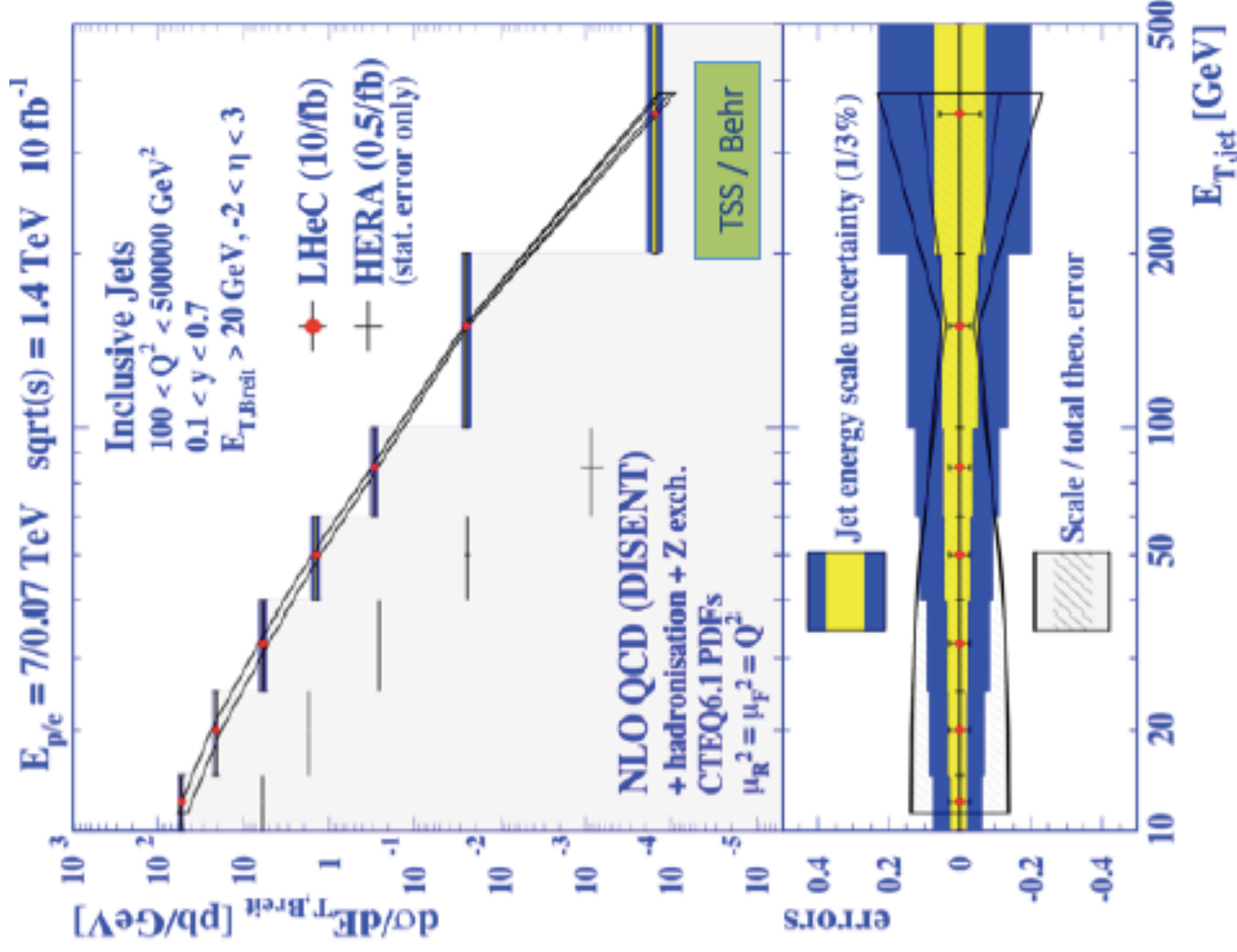

Also differential in Q^2 with high precision to beyond $Q^2 = 10^5 \text{ GeV}^2$

α_s up to scale $\sim 400 \text{ GeV}$

Detailed studies of QCD dynamics, including novel low x effects in regions not probed at HERA and (probably) not at LHC

Low-x Physics and Parton Saturation

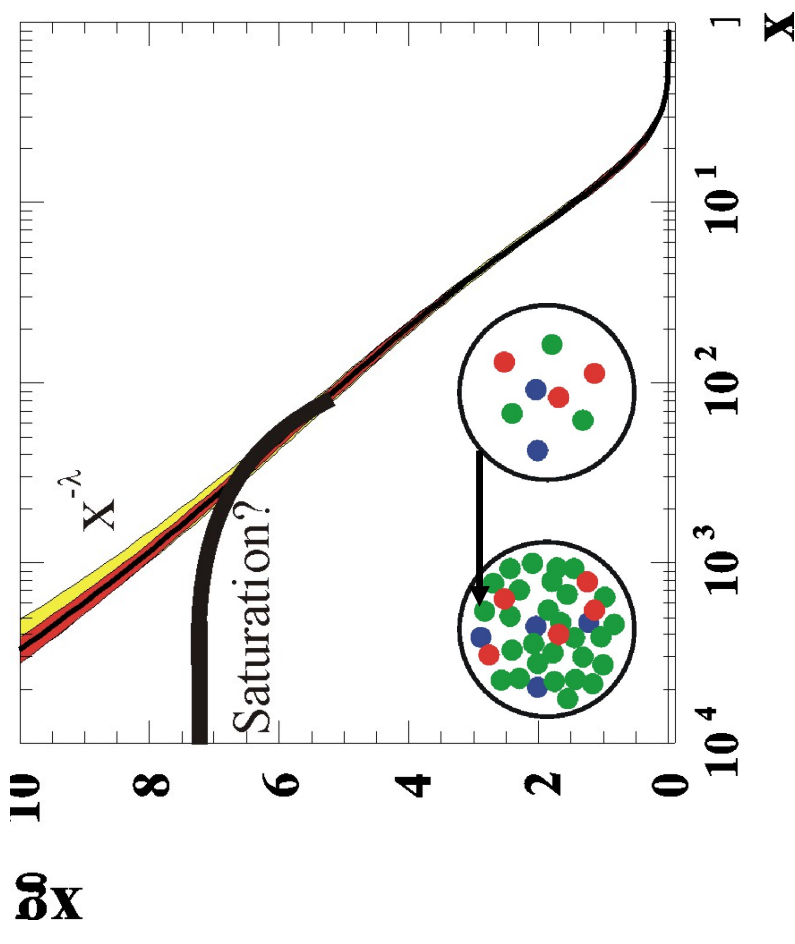
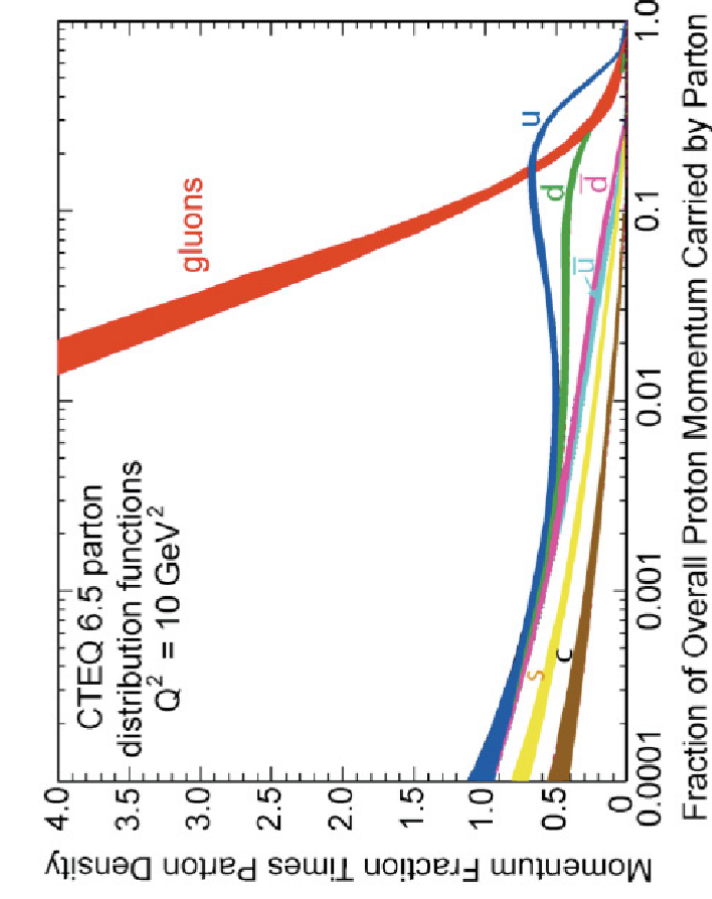

- Somewhere & somehow, the low x growth of cross sections must be tamed to satisfy unitarity ... non-linear effects
- Parton level language \rightarrow recombination $gg \rightarrow g$
- Saturation effects beyond x , A dependent saturation scale

$$Q_s^2 \sim xg(x)\alpha_s \sim cx^{-\lambda} A^{1/3}$$

- Weak hints at saturation effects @ HERA (but at very low Q^2)

Strategy for making the target blacker

LHeC delivers a 2-pronged approach:

- Enhance target 'blackness' by:
- 1) Probing lower x at fixed Q^2 in ep [evolution of a single source]
- 2) Increasing target matter in eA

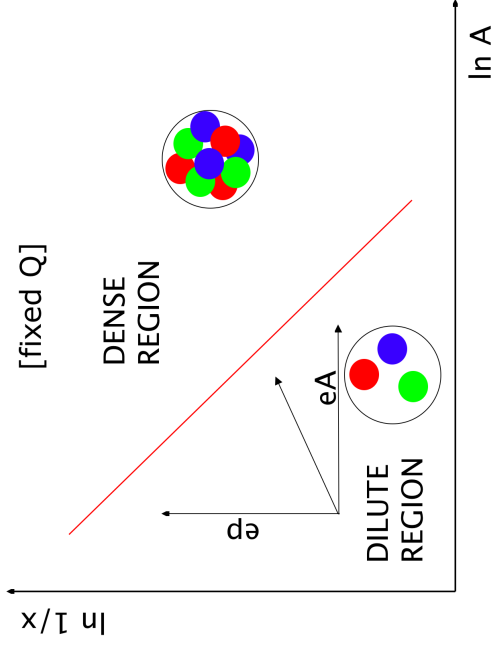

[overlapping many sources at fixed kinematics ... density ~ $A^{1/3}$ ~ 6 for Pb ... worth 2 orders of magnitude in x]

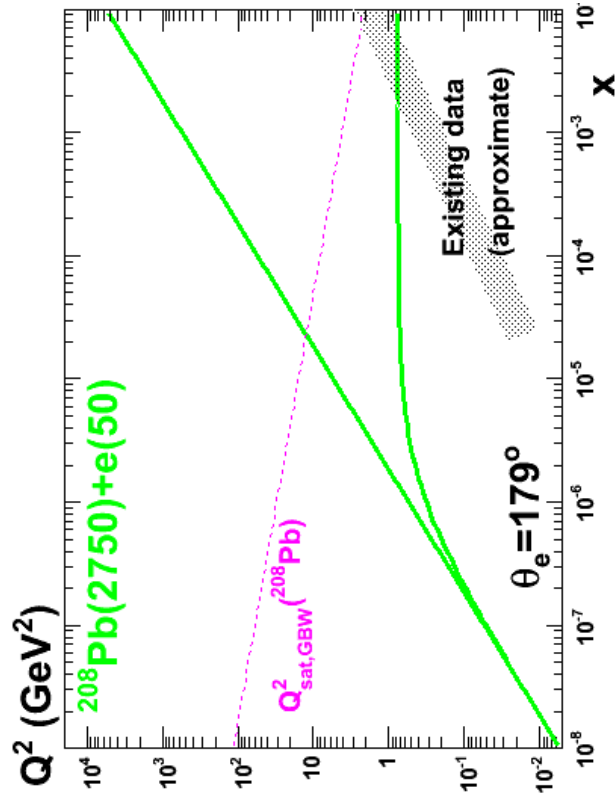
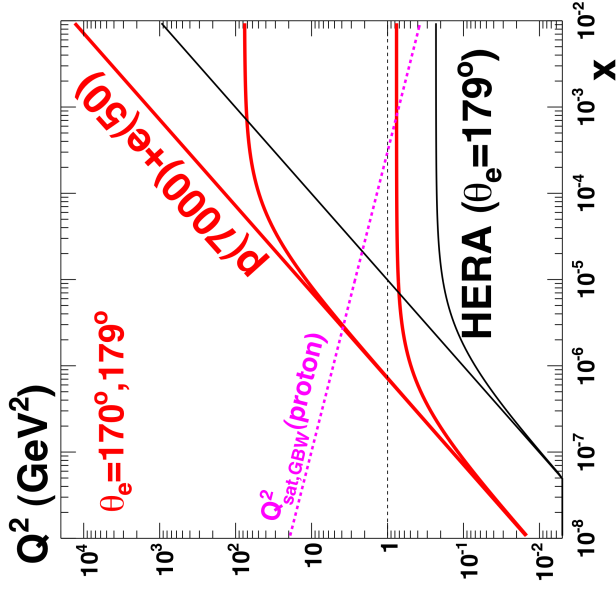

Extrapolating HERA models of F_2

With 1 fb⁻¹ (1 year at 10³² cm⁻² s⁻¹), F_2 stat. < 0.1%, syst, 1-3%
 F_L measurement to 8% with 1 year of varying E_e or E_p

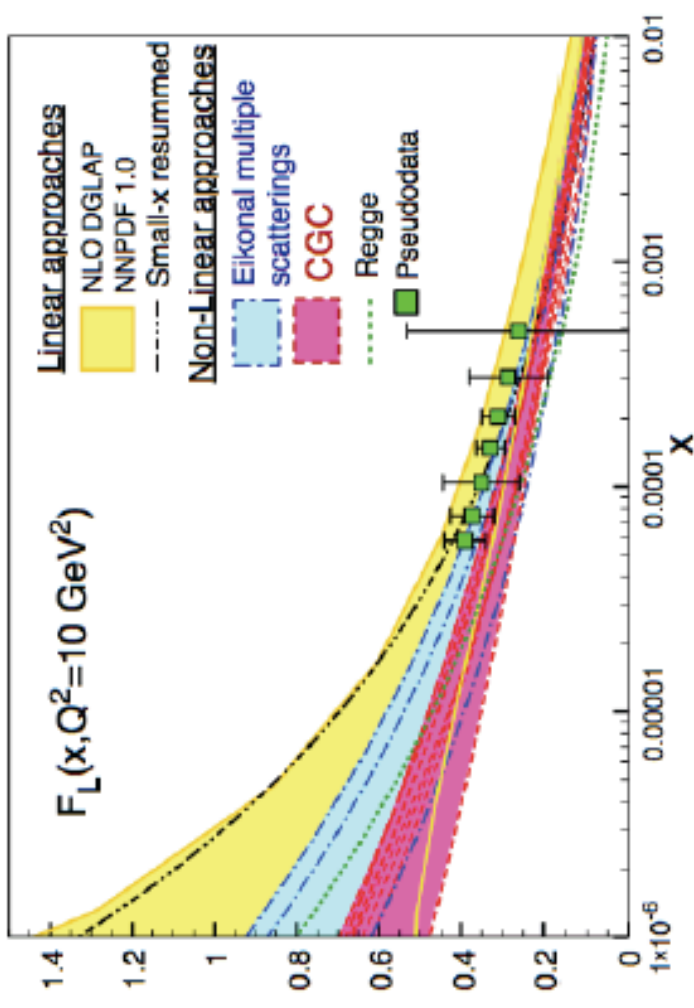
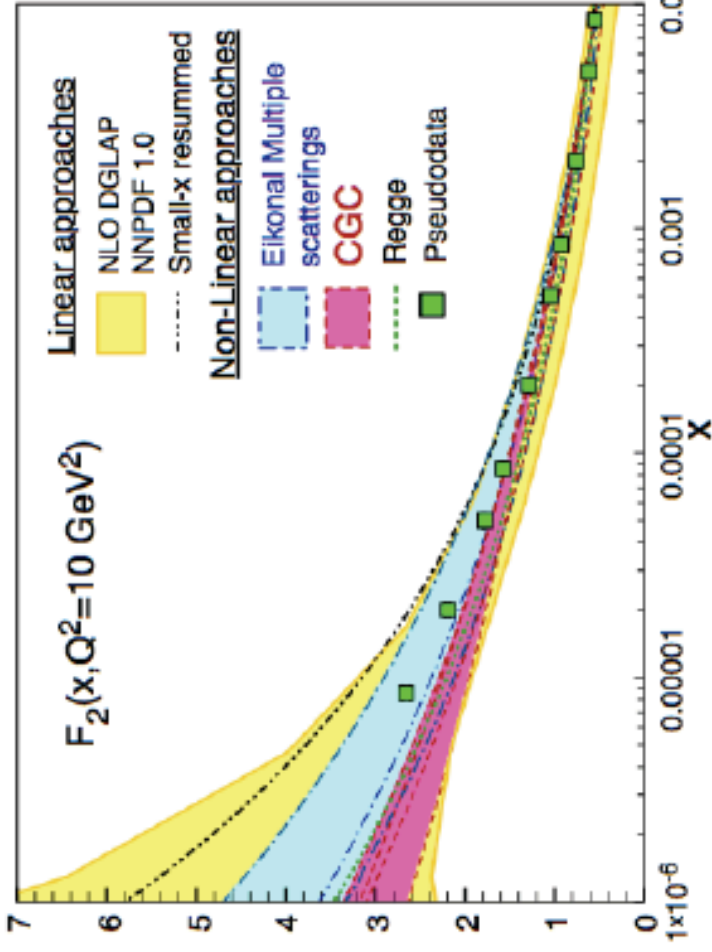

NLO DGLAP uncertainties explode @ low x and Q^2

- ‘Modern’ dipole models, containing saturation effects & low x behaviour derived from QCD give a much narrower range
- ... we should be able to distinguish between different models for the onset of saturation effects

Can Parton Saturation be Established in ep @ LHeC?

Simulated LHeC F_2 and F_L data based on a dipole model containing low x saturation (FS04-sat)...

... NNPDF (also HERA framework) DGLAP QCD fits cannot accommodate saturation effects if F_2 and F_L both fitted

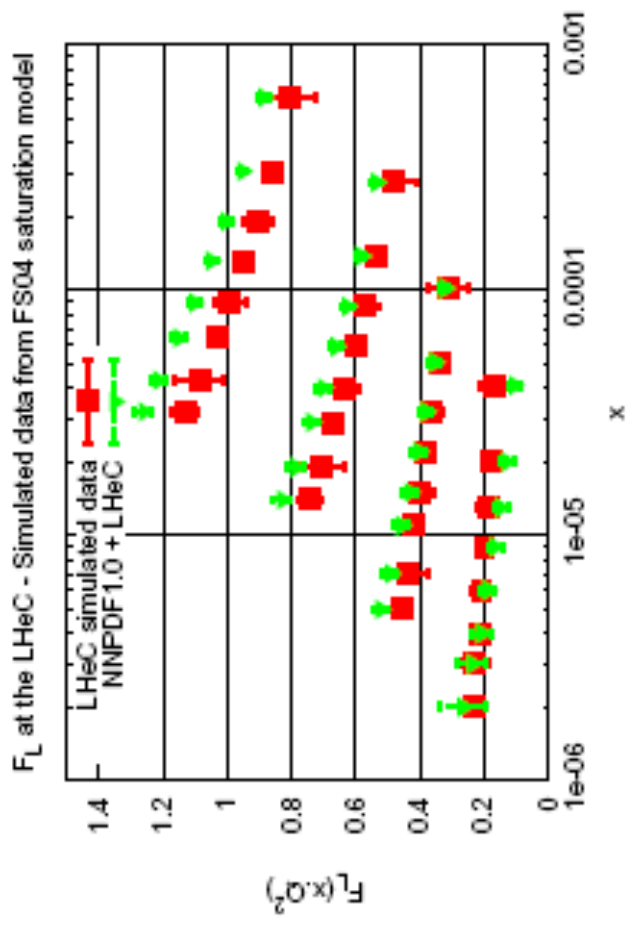
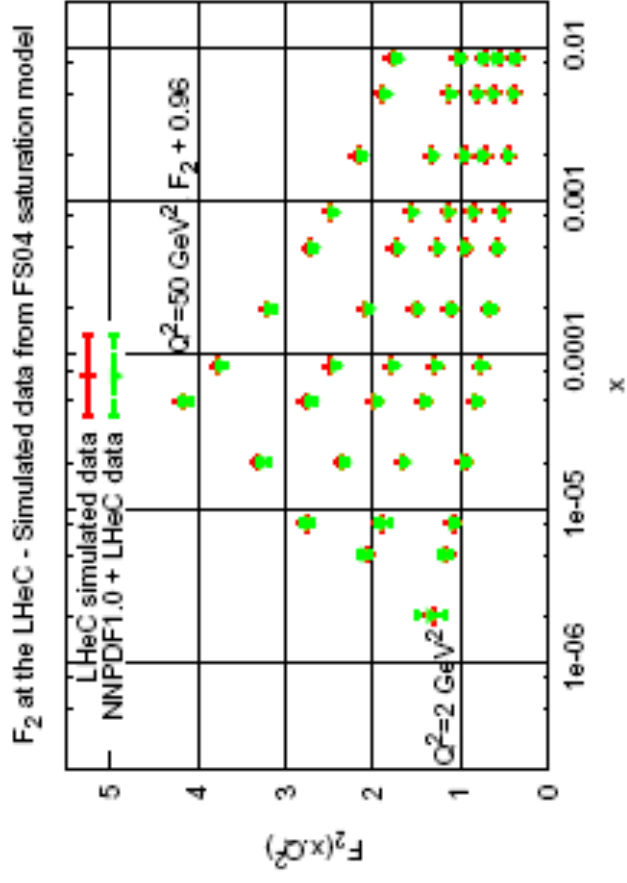

Conclusion: clearly establishing non-linear effects needs a minimum of 2 observables ... (F_2^c may work in place of F_L)...

Exclusive / Diffractive Channels and Saturation

- 1) [Low-Nussinov] interpretation as 2 gluon exchange enhances sensitivity to low x gluon
- 2) Additional variable t gives access to impact parameter (b) dependent amplitudes

→ Large t (small b) probes densest packed part of proton?

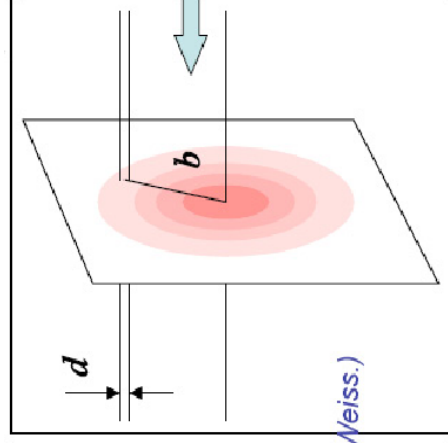

(figure from C. Weiss.)

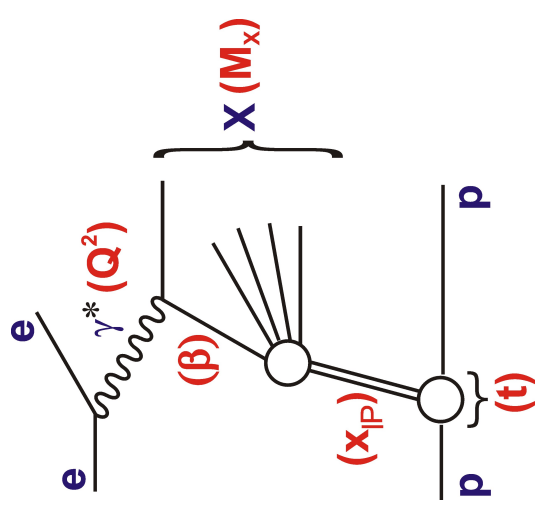
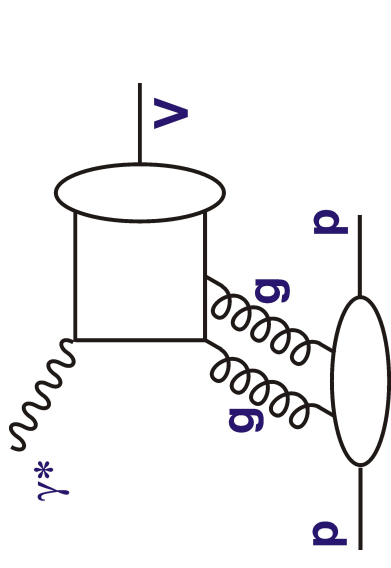

Simulation of J/ψ Photoproduction

- e.g. “b-Sat” Dipole model
- “eikonalised”: with impact-parameter dependent saturation
- “1 Pomeron”: non-saturating

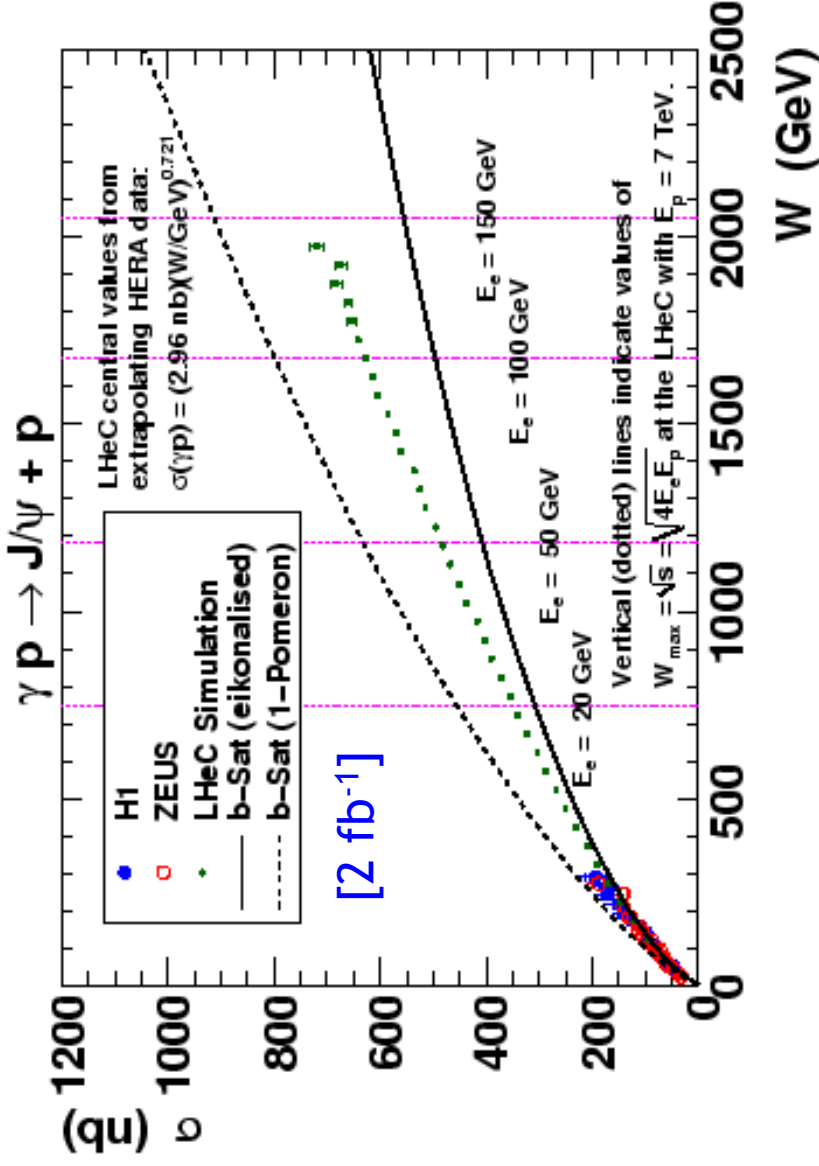
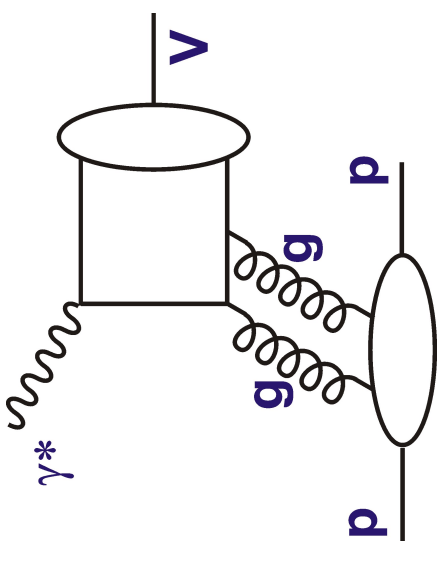

- Significant non-linear effects expected in LHeC kinematic range.

- Data shown are extrapolations of HERA power law fit for $E_e = 150 \text{ GeV}$...
 \rightarrow Satⁿ smoking gun?

What is Initial State of LHC AA Collisions?

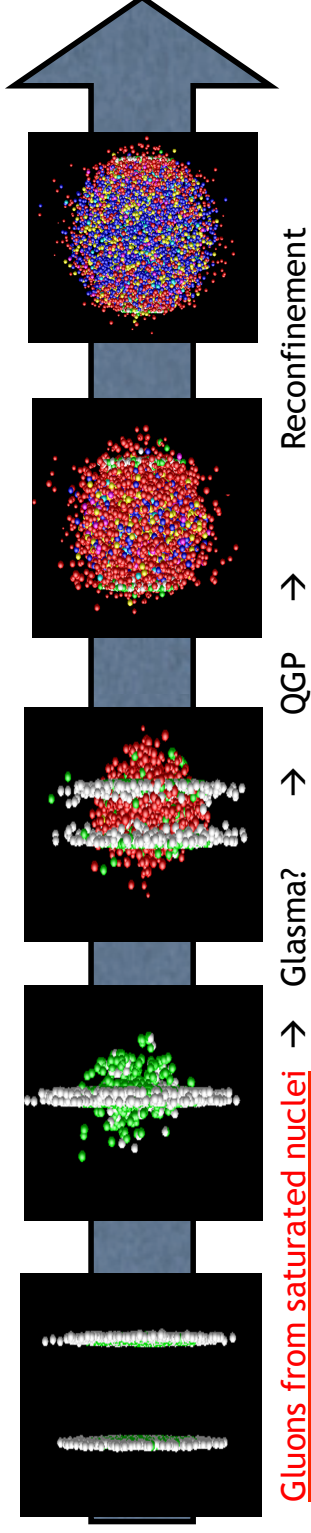

- Very limited x , Q^2 and A range for F_2^A so far (fixed target experiments covered $x > \sim 10^{-2}$)

- LHeC extends kinematic range by 3-4 orders of magnitude with very large A

[and eA potentially provides control for AA QGP signatures]

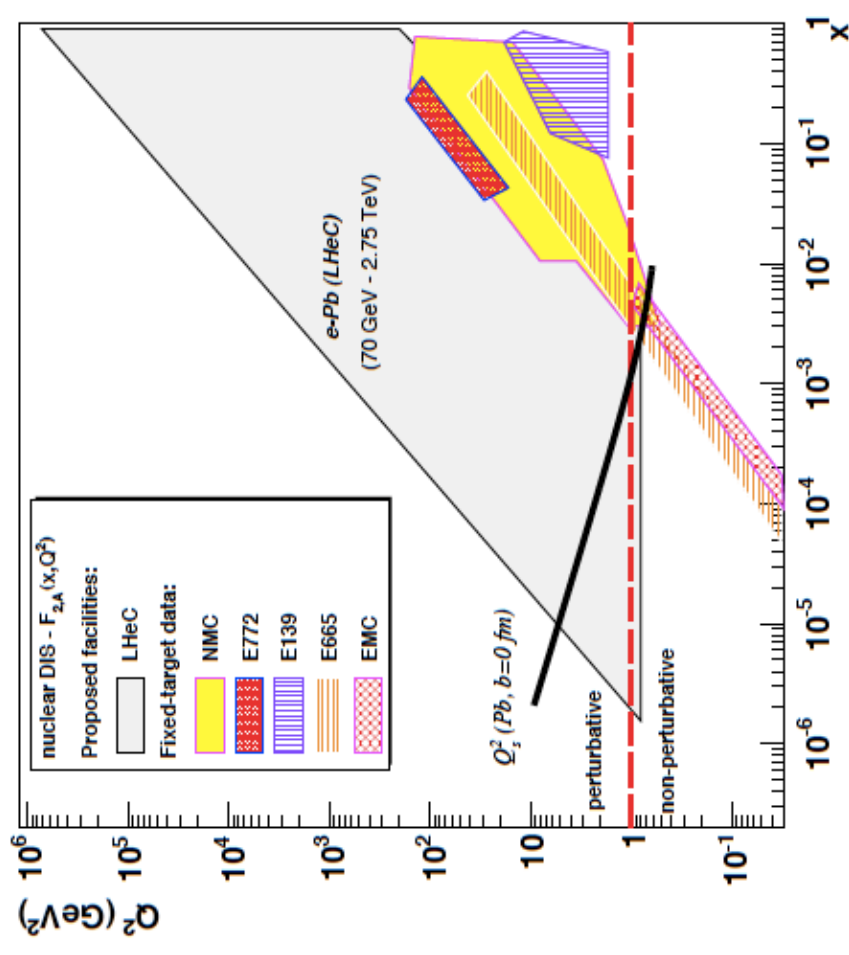

Current Knowledge: Nuclear Parton Densities

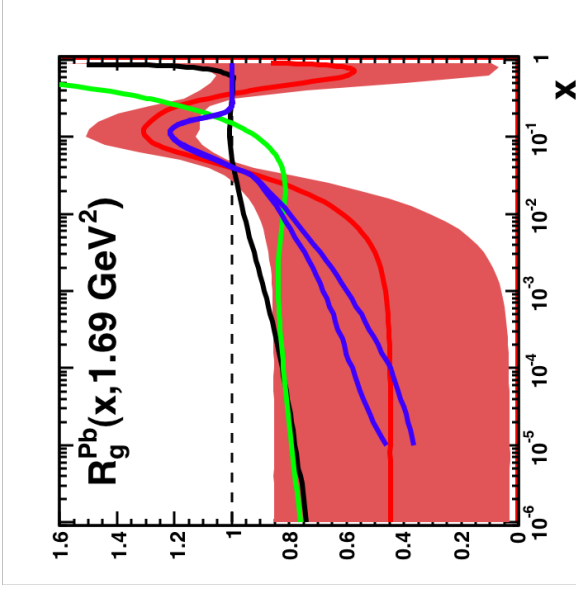
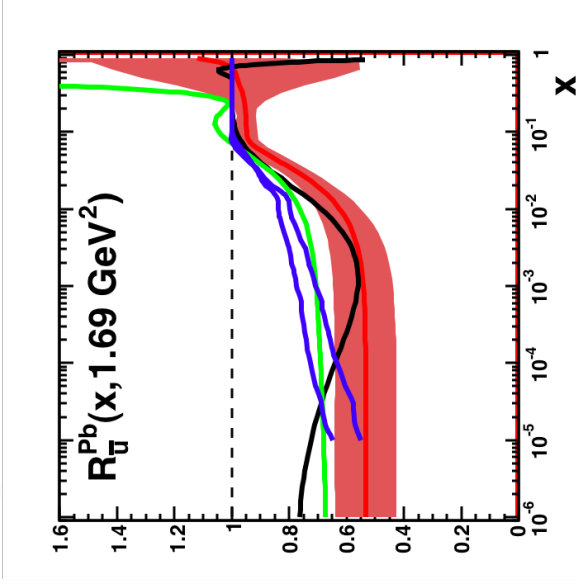
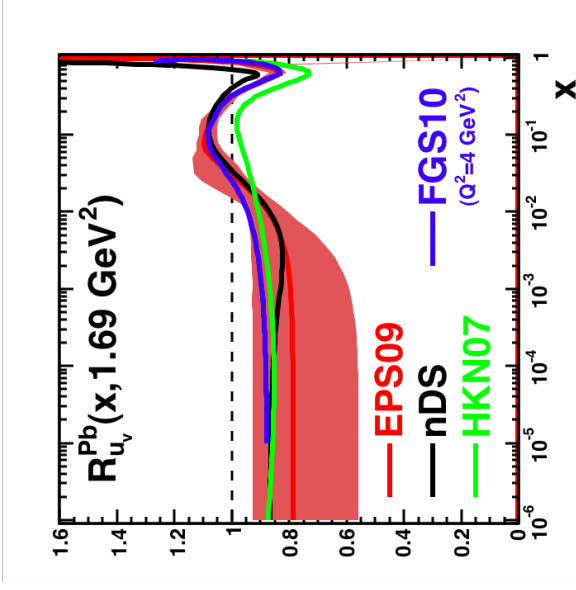

$$R_i = \text{Nuclear PDF } i / (A * \text{proton PDF } i)$$

- Nuclear parton densities don't scale with A due to Fermi motion, shadowing corrections ...
- All parton types poorly constrained for $x < 10^{-2}$
- Gluon density essentially unknown

Study of Impact of e-Pb LHC data

- LHeC ePb F_2 measurement has huge impact relative to current uncertainties
- Striking effect on quark sea and gluons in particular
- High x gluon uncertainty remains large

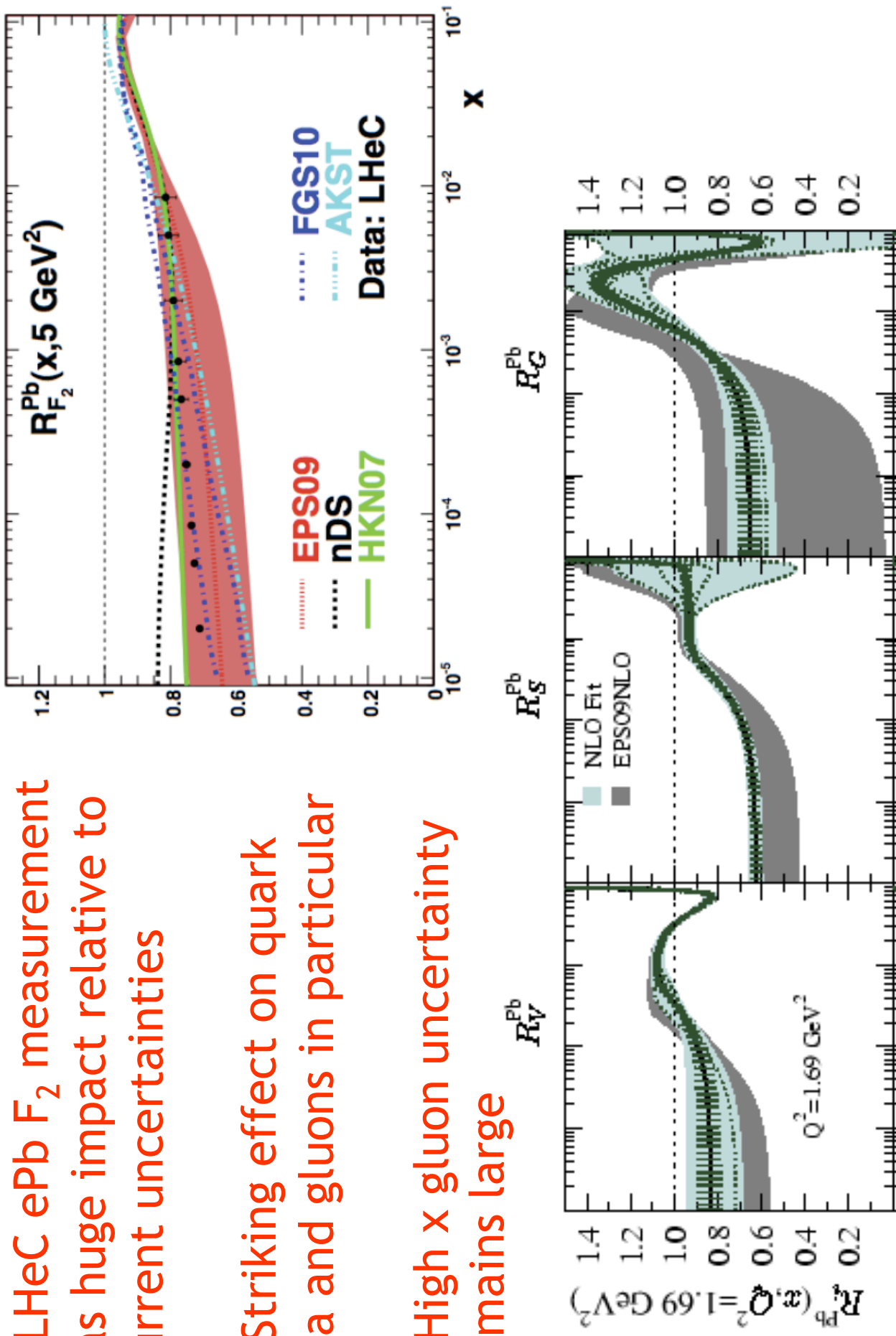

Schedule and Remarks

- Aim to start operation by 2022 [new phase of LHC]
→ cf HERA: Proposal 1984 - Operation 1992. LEP: Proposal 1983 - Operation 1989
- The major accelerator and detector technologies exist
- Cost is modest in major HEP project terms
- Steps: **Conceptual Design Report, 2012**
Evaluation within CERN / European PP/NP strategy
If positive, move towards a TDR 2013/14

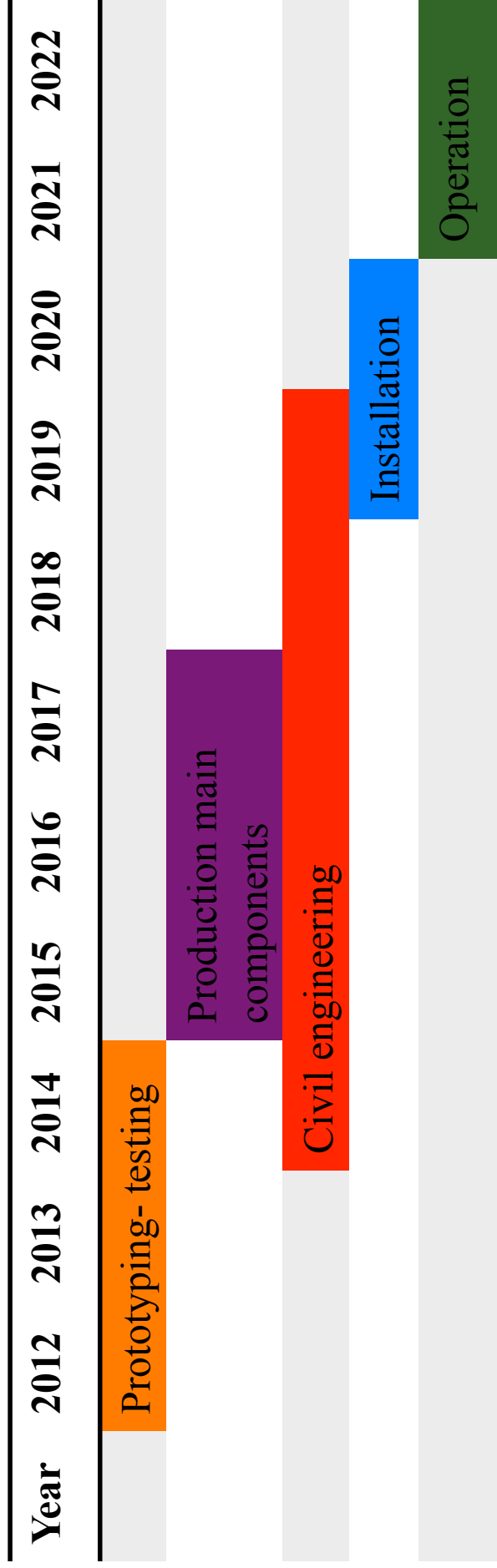

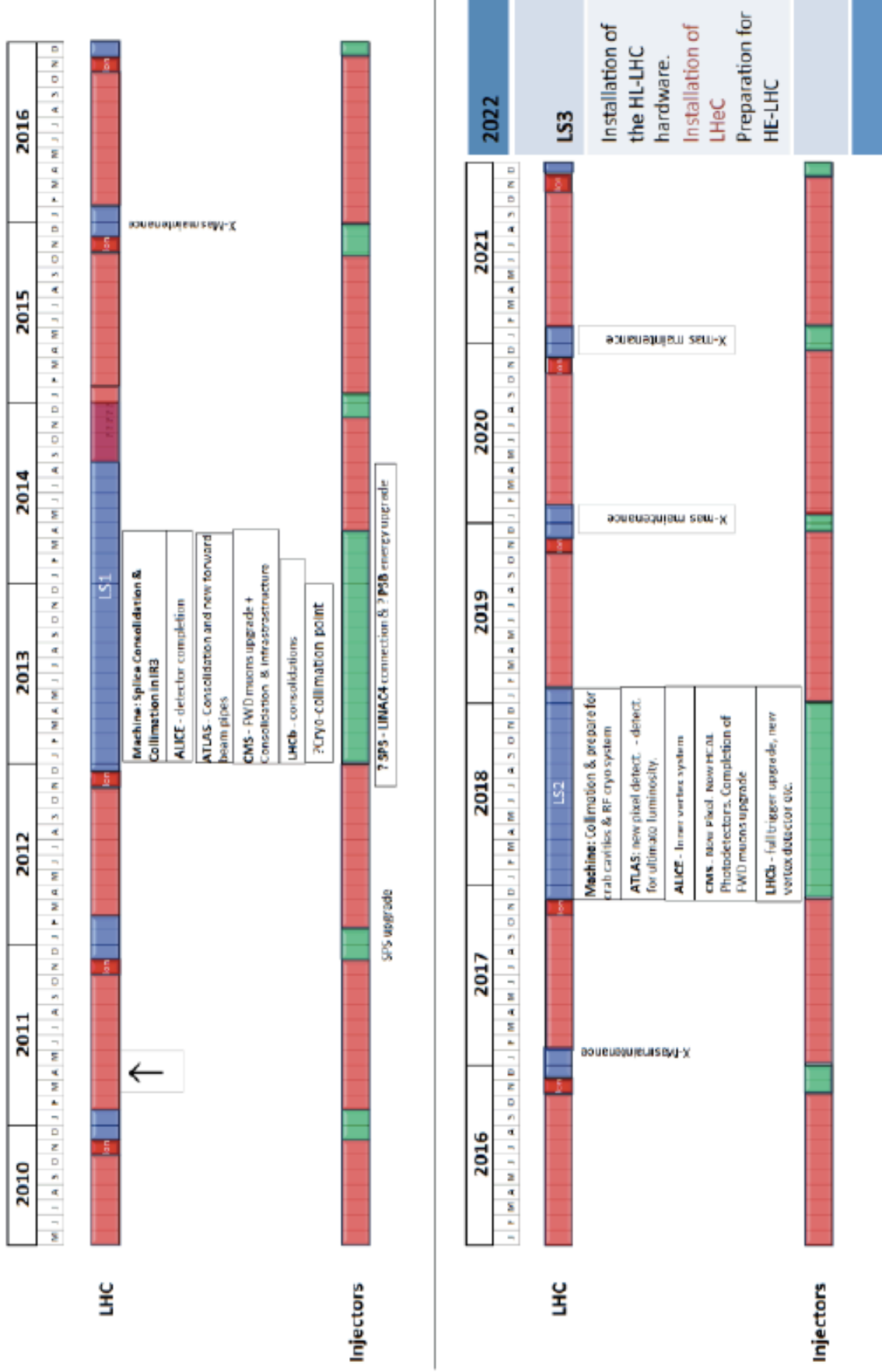

Figure 11.1: CERN medium term plan (MTP), draft as of July 2011

[Also appears in NuPeCC long range plan]

Summary

- LHC is a totally new world of energy and luminosity! LHeC proposal aims to exploit it for lepton-hadron scattering
 - ... ep complementing LHC and next generation ee facility for full Terascale exploration
- Ongoing ECFA/CERN/NuPECC workshop has gathered many accelerator, theory & experimental colleagues

→ Conceptual Design Report will be available soon

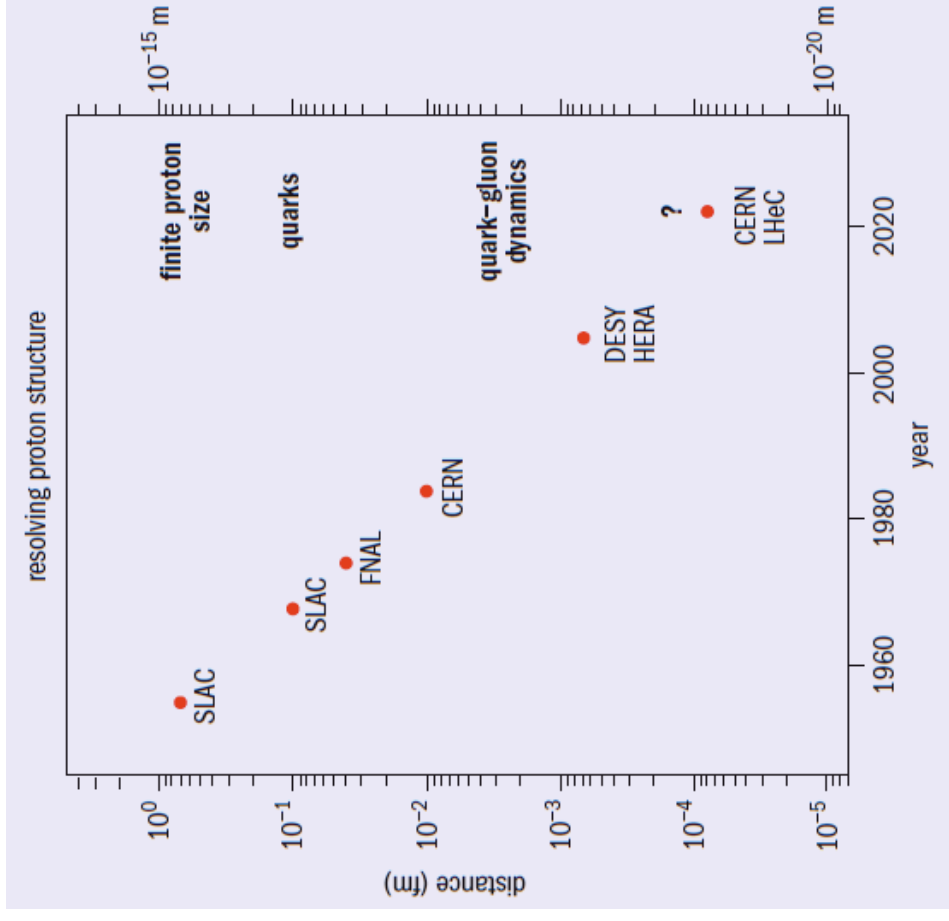

Fig. 1. Distance scales resolved in successive lepton-hadron scattering experiments since the 1950s, and some of the new physics revealed.

[More at <http://cern.ch/lhec>]

... with thanks to many colleagues working on LHeC ...

<http://cern.ch/lhec>



LHeC Study Group

J. Abelleira, Fernandez^{10,15}, C. Adolphsen³⁹, S. Alekhin^{40,11}, A.N. Akai⁰¹, H. Aksakal³⁰, P. Allport¹⁷, J.L. Albacete³⁷, V. Andreev²⁵, R.B. Appleby²³, N. Armesto³⁸, G. Azuelos²⁶, M. Bai⁴⁷, D. Barber¹¹, J. Bartels¹², J. Behr¹¹, O. Behnke¹¹, S. Belyaev¹⁰, I. BenZvi⁴⁷, N. Bernard¹⁶, S. Bertolucci¹⁰, S. Bettoni¹⁰, S. Biswal³², J. Bluemlein¹¹, H. Boettcher¹¹, H. Braun⁴⁸, S. Brodsky³⁹, A. Bogacz²⁸, C. Bracco¹⁰, O. Bruening¹⁰, E. Bulyak⁰⁸, A. Bumyatian¹¹, H. Burkhardt¹⁰, I.T. Cakir⁵⁴, O. Cakir⁵³, R. Calaga⁴⁷, E. Ciapala¹⁰, R. Ciftci⁰¹, A.K. Ciftci⁰¹, B.A. Cole²⁹, J.C. Collins⁴⁶, J. Dainton¹⁷, A. De Roeck¹⁰, D. d'Enterria¹⁰, A. Dudarev¹⁰, A. Eide⁴³, E. Eroglu⁴⁵, K.J. Eskola¹⁴, L. Favart⁰⁶, M. Fitterer¹⁰, S. Forte²⁴, P. Gambino⁴², T. Gehrmann⁵⁰, C. Glasman²², R. Godbole²⁷, B. Goddard¹⁰, T. Greenshaw¹⁷, A. Guffanti⁰⁹, V. Guzey²⁸, C. Gwenlan³⁴, T. Han³⁶, Y. Hao⁴⁷, F. Haug¹⁰, W. Herr¹⁰, B. Holzer¹⁰, M. Ishitsuka⁴¹, M. Jacquet³³, B. Jeanneret¹⁰, J.M. Jimenez¹⁰, H. Jung¹¹, J.M. Jowett¹⁰, H. Karadeniz⁵⁴, D. Kayran⁴⁷, F. Kocac⁴⁵, A. Kilic⁴⁵, K. Kimura⁴¹, M. Klein¹⁷, U. Klein¹⁷, G. Kramer¹², M. Korostelev²³, A. Kosmicki¹⁰, P. Kostka¹¹, H. Kowalski¹¹, D. Kuchler¹⁰, M. Kuze⁴¹, T. Lappi¹⁴, P. Laycock¹⁷, E. Levichev³¹, S. Levonian¹¹, V.N. Litvinenko⁴⁷, A. Lombardi¹⁰, C. Marquet¹⁰, B. Mellado⁰⁷, K.H. Mess¹⁰, S. Moch¹¹, I.I. Morozov³¹, Y. Muttoni¹⁰, S. Myers¹⁰, S. Nandi²⁶, P.R. Newman⁰³, T. Omori⁴⁴, J. Osborne¹⁰, Y. Papaphilippou¹⁰, E. Paoloni³⁵, C. Pascaud³³, H. Paukkunen³⁸, E. Perez¹⁰, T. Pieloni¹⁵, E. Pilicer⁴⁶, A. Polini⁰⁴, V. Pitsyn⁴⁷, Y. Pupkov³¹, V. Radescu¹³, S. Raychaudhuri²⁷, L. Rinolfi¹⁰, R. Rohini²⁷, J. Rojo²⁴, S. Russenschuck¹⁰, C.A. Salgado³⁸, K. Sampei⁴¹, E. Sauvan¹⁹, M. Sahin⁰¹, U. Schneekloth¹¹, A.N. Skrinsky³¹, T. Schoerner Sadenius¹¹, D. Schulte¹⁰, H. Spiesberger²¹, A.M. Stasto⁴⁶, M. Strikman⁴⁶, M. Sullivan³⁹, B. Surrow⁰⁵, S. Sultansoy⁰¹, Y.P. Sun³⁹, W. Smith²⁰, I. Tapan⁴⁵, P. Taelis⁰², E. Tassi⁵², H. Ten Kate¹⁰, J. Terron²², H. Thiesen¹⁰, L. Thompson²³, K. Tokushuku⁴⁴, R. Tomas Garcia¹⁰, D. Tommasini¹⁰, D. Trbojevic⁴⁷, N. Tsoupas⁴⁷, J. Tuckmantel¹⁰, S. Turkoz⁵³, K. Tywoniuk¹⁸, G. Unel¹⁰, J. Urakawa⁴⁴, P. Van Mechelen⁰², A. Variola³⁷, R. Veness¹⁰, A. Vivoli¹⁰, P. Vobly³¹, R. Wallny⁵¹, G. Watt¹⁰, G. Weiglein¹², C. Weiss²⁸, U.A. Wiedemann¹⁰, U. Wienands³⁹, F. Willeke⁴⁷, V. Yakimenko⁴⁷, A.F. Zarniecki⁴⁹, F. Zimmermann¹⁰, F. Zomer³³