

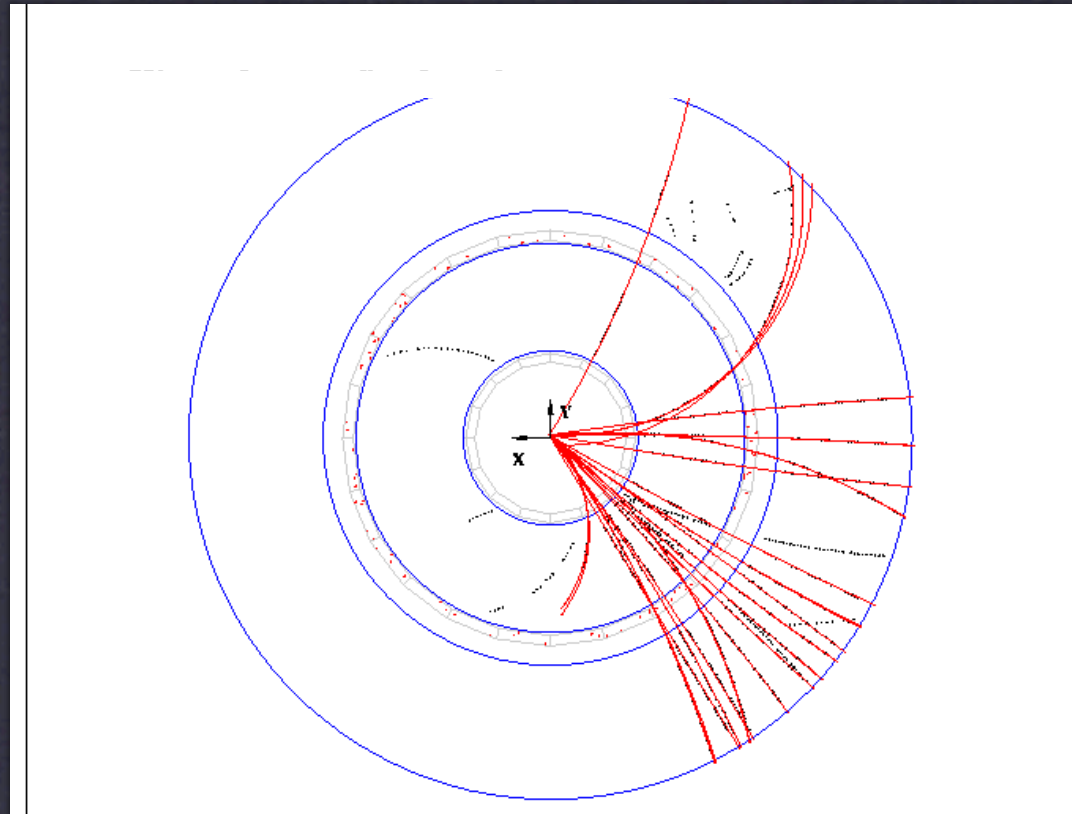

Queen Mary
University of London



NON-PERTURBATIVE

Particle Production from a HERA perspective

Daniel Traynor, Birmingham seminar

15/10/09

Overview

- * The Trouble With QCD.
- * HERA and the H1 experiment.
- * Fragmentation functions.
- * Strangeness production.
- * Bonus : More strangeness, Instantons, Pentaquarks, Glueballs

The Trouble With QCD

QED

TO CUT A LONG STORY SHORT. THE INVARIANCE OF THE QED LAGRANGIAN UNDER LOCAL GAUGE TRANSFORMATIONS REQUIRES THE EXISTENCE OF A GAUGE FIELD. THIS IS THE ELECTROMAGNETIC FIELD AND MEDIATES THE FORCE BETWEEN CHARGED PARTICLES. THE QUANTA OF THIS FIELD ARE THE MASSLESS PHOTONS

FIELD STRENGTH TENSOR

$$F_{\mu\nu} = \delta_{\mu}A_{\nu} - \delta_{\nu}A_{\mu}$$

SYMBOLICALLY THE QED LAGRANGIAN HAS THESE TERMS

U(1) SYMMETRY

ABELIAN

VECTOR FIELD A_{μ} (GAUGE FIELD) WHICH COUPLES TO CHARGE. IT IS A NUMBER

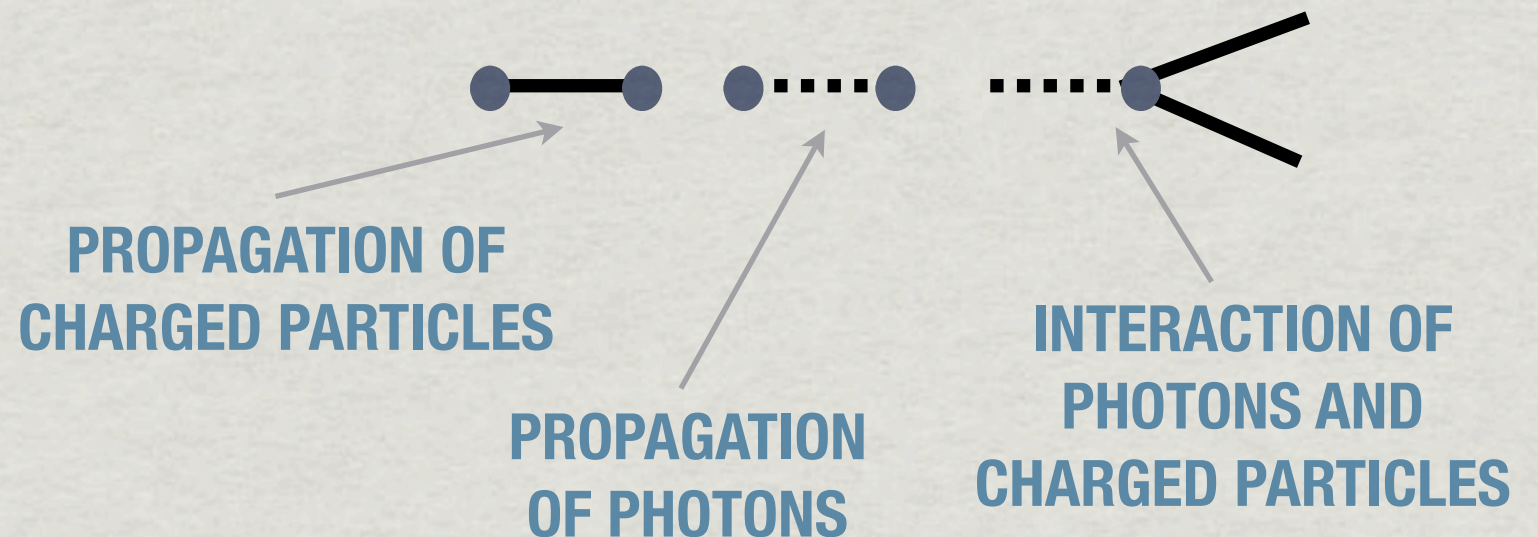

The Trouble With QCD

QCD

TO CUT A LONG STORY SHORT. THE INVARIANCE OF THE QCD LAGRANGIAN UNDER LOCAL GAUGE TRANSFORMATIONS REQUIRES THE EXISTENCE OF A GAUGE FIELD. THIS IS THE COLOUR FIELD AND MEDIATES THE FORCE BETWEEN COLOURED PARTICLES. THE QUANTA OF THIS FIELD ARE THE MASSLESS GLUONS

SU(3) SYMMETRY

NON-ABELIAN

VECTOR FIELD A_μ (GAUGE FIELD) WHICH COUPLES TO COLOUR. IT IS A MATRIX

FIELD STRENGTH TENSOR

$$F_{\mu\nu} = \delta_\mu A_\nu - \delta_\nu A_\mu - ig[A_\mu A_\nu - A_\nu A_\mu]$$

SELF INTERACTION TERM

SYMBOLICALLY THE QCD LAGRANGIAN HAS THESE TERMS

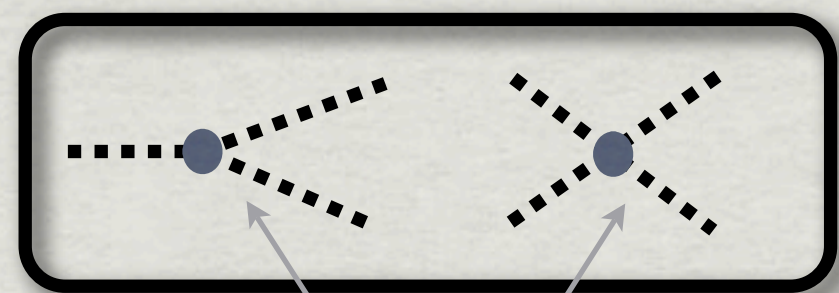

THREE AND FOUR GLUON VERTICES

The Trouble With QCD

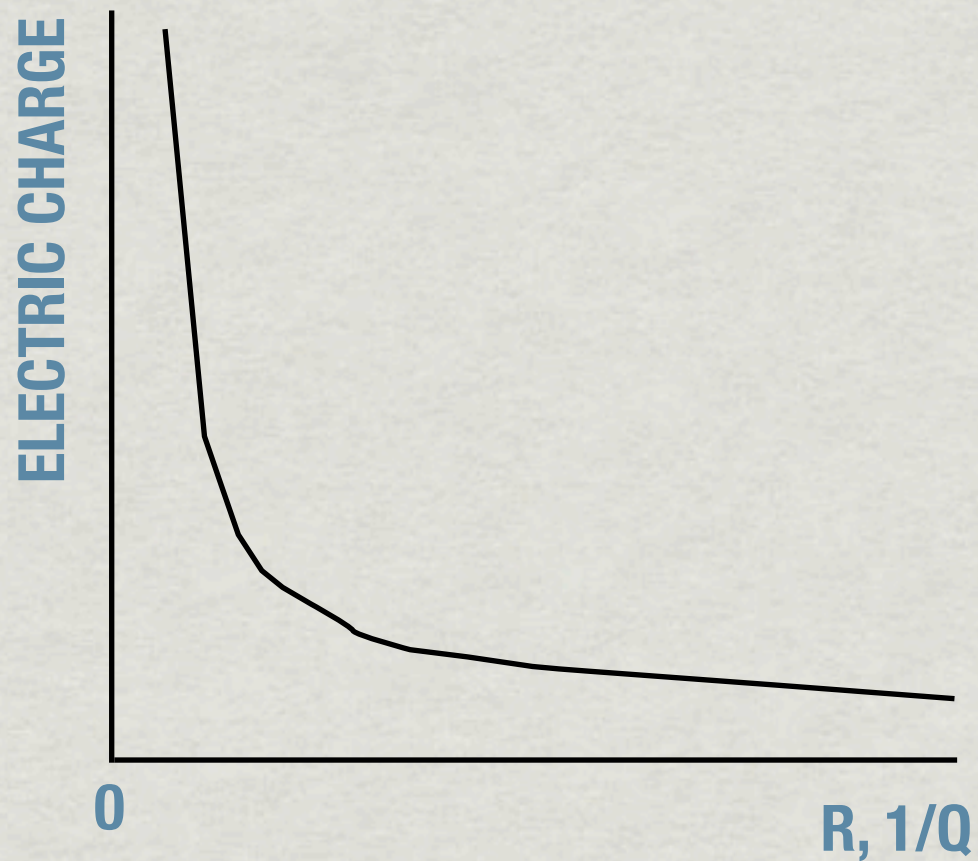

SCREENING OF ELECTRIC CHARGE

**IN QED HIGHER ORDER PROCESSES ARE
LESS IMPORTANT DUE TO THE
SMALLNESS OF α_{em} (1/137).**

The Trouble With QCD

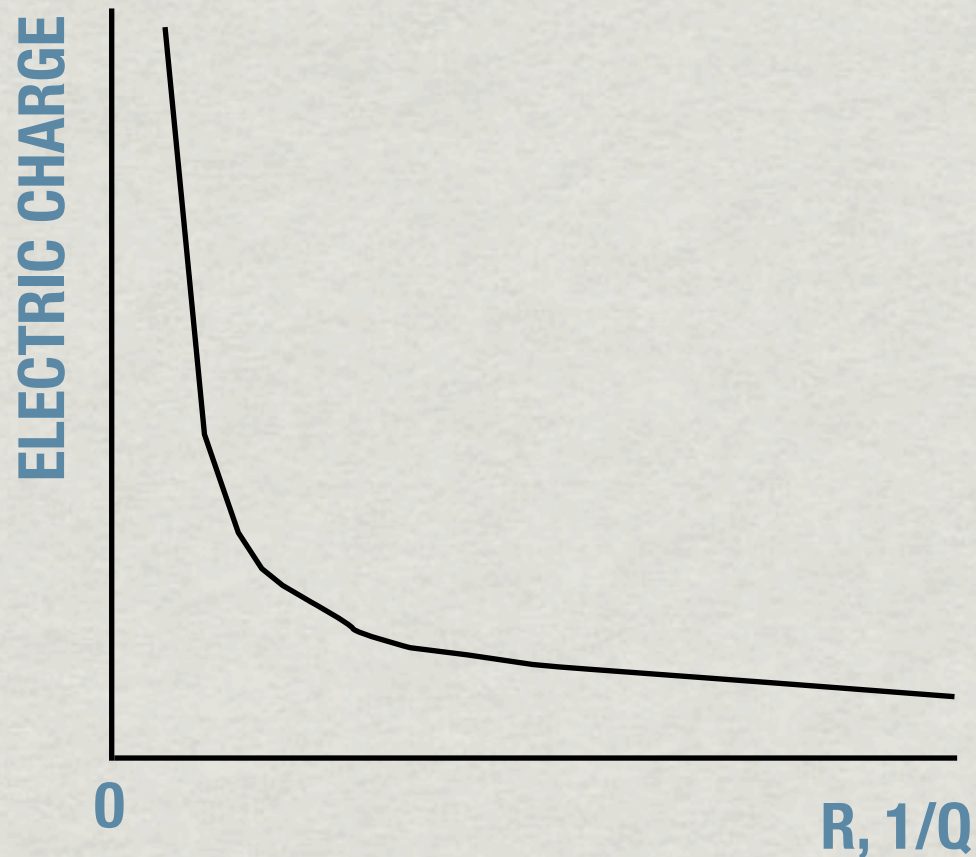

SCREENING OF ELECTRIC CHARGE

IN QED HIGHER ORDER PROCESSES ARE LESS IMPORTANT DUE TO THE SMALLNESS OF α_{em} (1/137).

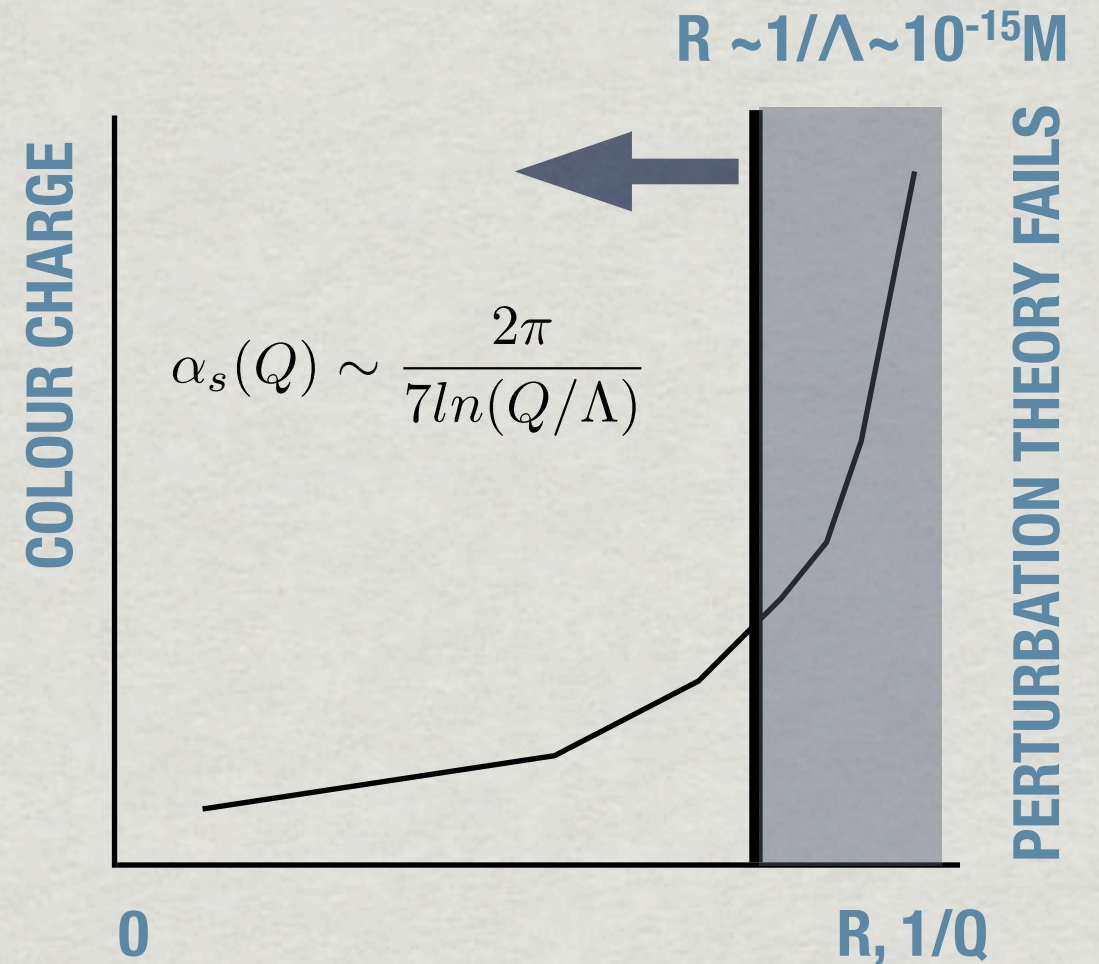

ANTI SCREENING OF COLOUR CHARGE

AT LARGE DISTANCES α_s BECOMES LARGE (~1) AND HIGHER ORDER PROCESSES BECOME MORE IMPORTANT

ASYMPTOTIC FREEDOM AT SMALL DISTANCES

THE PERTURBATIVE EXPANSION

QED

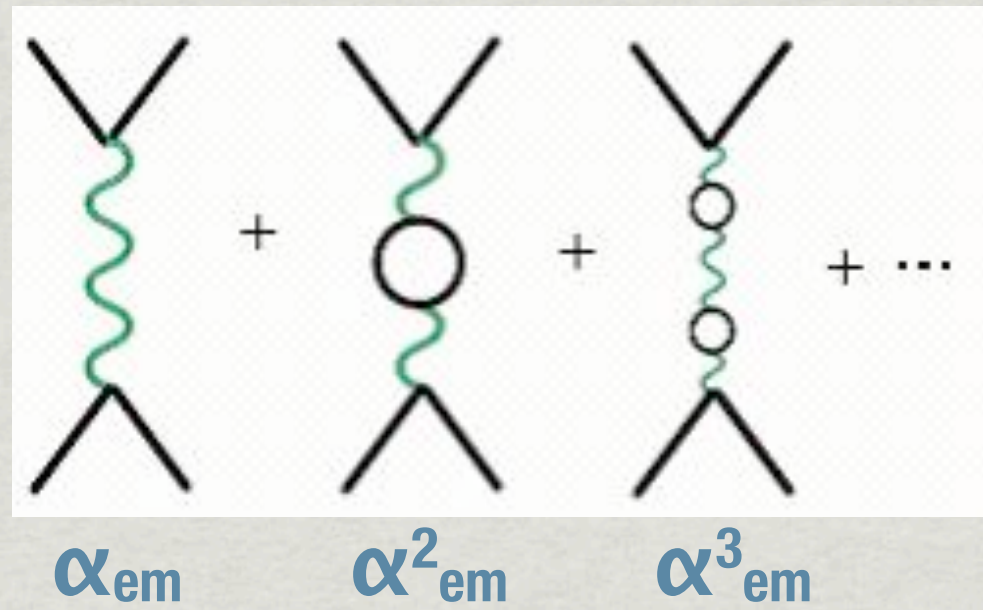

THE PERTURBATIVE EXPANSION

QED

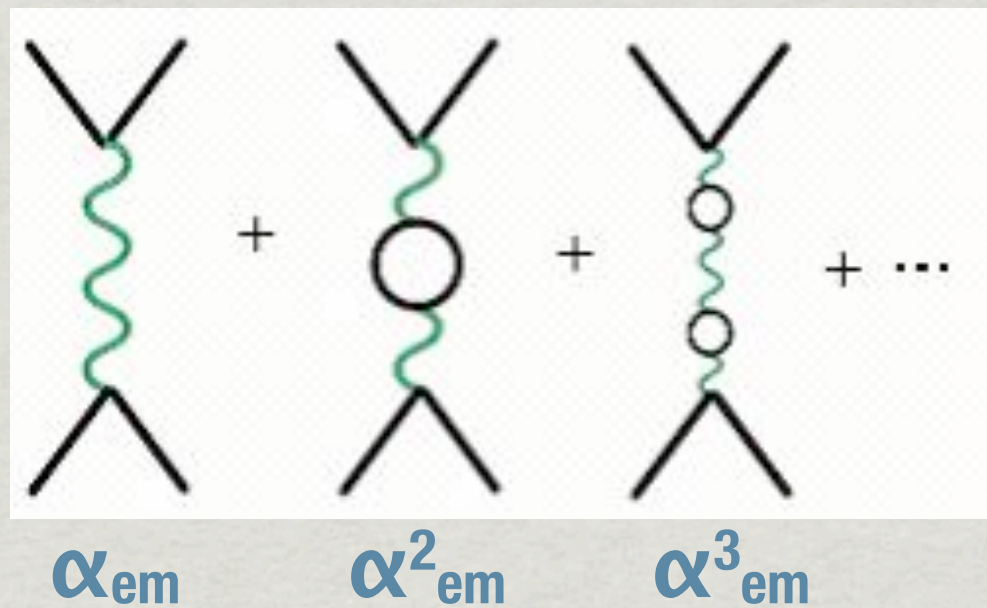

QCD

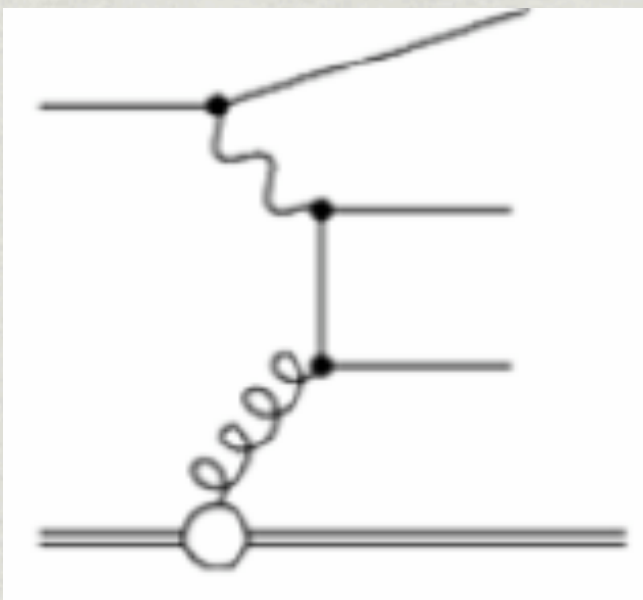

α_s

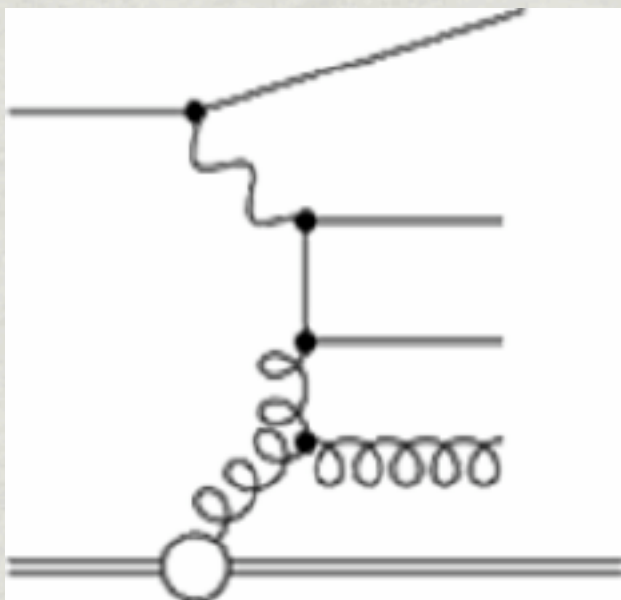

α^2_s

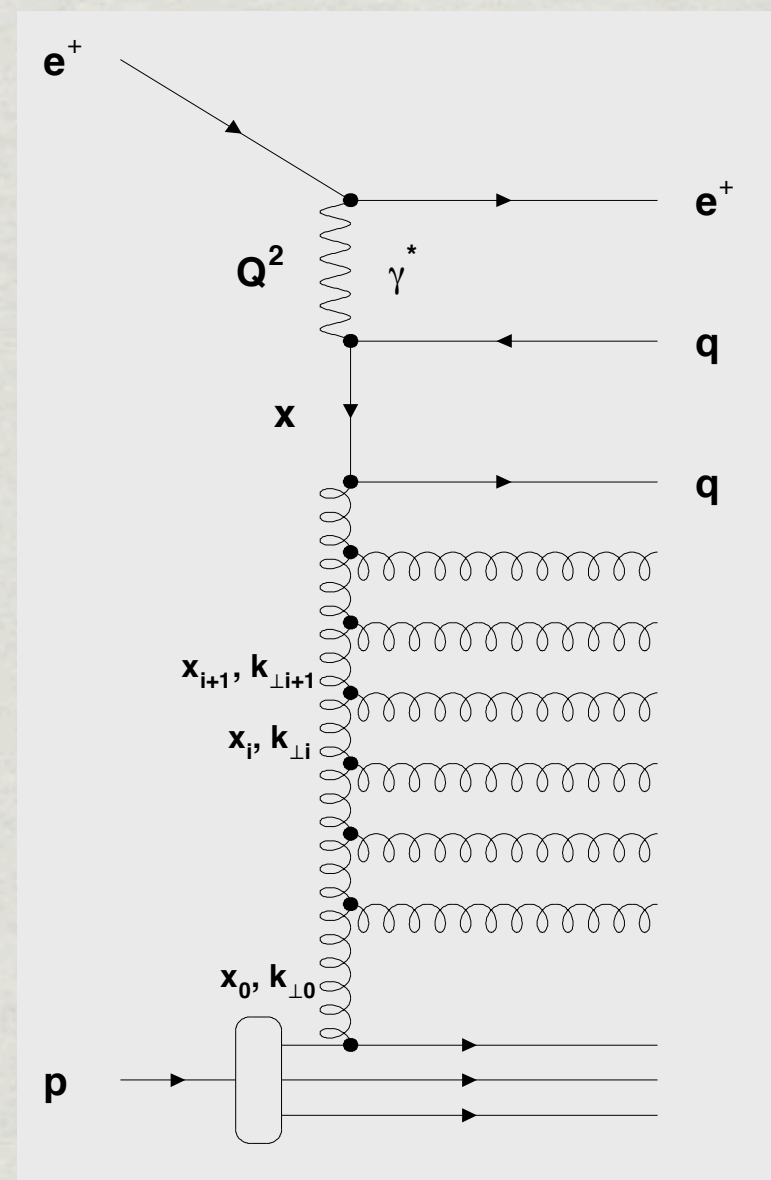

α^n_s

NLO time-like splitting functions (diagonal singlet)

α_s^2

$$\delta P_{ns,+}^{(1)}(x) \equiv P_{ns,+}^{(1)T}(x) - P_{ns,+}^{(1)S}(x) =$$

$$4C_F^2 \left(H_0(6(1-x)^{-1} - 5 - x) + H_{0,0}(-8(1-x)^{-1} + 6 + 6x) + (H_{1,0} + H_2)(-8(1-x)^{-1} + 4 + 4x) \right).$$

$q \rightarrow q(g)$

$$\delta P_{ps}^{(1)}(x) \equiv P_{ps}^{(1)T}(x) - P_{ps}^{(1)S}(x) =$$

$$8C_F n_f \left(-20/9 x^{-1} - 3 - x + 56/9 x^2 - (3 + 7x + 8/3 x^2) H_0 + 2(1+x) H_{0,0} \right).$$

$g \rightarrow qqg$

$$\delta P_{gg}^{(1)}(x) \equiv P_{gg}^{(1)T}(x) - P_{gg}^{(1)S}(x) =$$

$$8C_A^2 \left(p_{gg}(x) \left[11/3 H_0 - 4(H_{0,0} + H_{1,0} + H_2) \right] + [6(1-x) - 22/3(x^{-1} - x^2)] H_0 - 8(1+x) H_{0,0} \right) - 16/3 C_A n_f p_{gg}(x) H_0 + 8C_F n_f \left(20/9 x^{-1} + 3 + x - 56/9 x^2 + [4 + 6x + 4/3(x^{-1} + x^2)] H_0 + 2(1+x) H_{0,0} \right).$$

$g \rightarrow g(g)$

...

NLO time-like splitting functions (diagonal singlet)

α_s^2

$$\delta P_{ns,+}^{(1)}(x) \equiv P_{ns,+}^{(1)T}(x) - P_{ns,+}^{(1)S}(x) = 4C_F^2 \left(H_0(6(1-x)^{-1} - 5 - x) + H_{0,0}(-8(1-x)^{-1} + 6 + 6x) + (H_{1,0} + H_2)(-8(1-x)^{-1} + 4 + 4x) \right).$$

q → q(g)

$$\delta P_{ps}^{(1)}(x) \equiv P_{ps}^{(1)T}(x) - P_{ps}^{(1)S}(x) = 8C_F n_f \left(-20/9 x^{-1} - 3 - x + 56/9 x^2 - (3 + 7x + 8/3 x^2) H_0 + 2(1+x) H_{0,0} \right).$$

g → qqg

$$\delta P_{gg}^{(1)}(x) \equiv P_{gg}^{(1)T}(x) - P_{gg}^{(1)S}(x) = 8C_A^2 \left(p_{gg}(x) \left[11/3 H_0 - 4(H_{0,0} + H_{1,0} + H_2) \right] + [6(1-x) - 22/3(x^{-1} - x^2)] H_0 - 8(1+x) H_{0,0} \right) - 16/3 C_A n_f p_{gg}(x) H_0 + 8C_F n_f \left(20/9 x^{-1} + 3 + x - 56/9 x^2 + [4 + 6x + 4/3(x^{-1} + x^2)] H_0 + 2(1+x) H_{0,0} \right).$$

g → g(g)

...

NNLO time-like splitting functions (diagonal singlet)

α_s^3

$$\delta P_{ps,+}^{(2)}(x) \equiv P_{ps,+}^{(2)T}(x) - P_{ps,+}^{(2)S}(x) = +16C_F^2 \left(p_{qq}(x) \left[311/24 H_0 + 4/3 H_0 \zeta_2 - 169/9 H_{0,0} + 8 H_{0,0} \zeta_2 - 22 H_{0,0,0} - 268/9 H_{1,0} + 8 H_{1,0} \zeta_2 - 44/3 H_{1,0,0} - 268/9 H_2 + 8 H_2 \zeta_2 - 44/3 H_{2,0} - 44/3 H_3 \right] + (1+x) \left[-4 H_{0,0} \zeta_2 + 25/2 H_{0,0,0} + H_{2,0} + 2 H_3 \right] - (1-x) \left[325/18 H_0 + 50/3 H_{1,0} + 50/3 H_2 \right] + (3-5x) H_0 \zeta_2 - (173/18 - 691/18 x) H_{0,0} \right) + 16C_F^2 (C_A - 2C_F) \left(p_{qq}(x) \left[151/24 H_0 + H_0 \zeta_3 + 13/6 H_0 \zeta_2 - 169/18 H_{0,0} + 8 H_{0,0} \zeta_2 - 13/2 H_{0,0,0} - 8 H_{0,0,0,0} - 134/9 H_{1,0} + 4 H_{1,0} \zeta_2 - 22/3 H_{1,0,0} - 6 H_{1,0,0,0} - 134/9 H_2 + 4 H_2 \zeta_2 - 22/3 H_{2,0} - 2 H_{2,0,0} - 22/3 H_3 - 2 H_{3,0} - 6 H_4 \right] + p_{qq}(-x) \left[-8 H_{-3,0} + 8 H_{-2,0} \zeta_2 + 8 H_{-2,-1,0} + 3 H_{-2,0} - 14 H_{-2,0,0} - 4 H_{-2,2} + 8 H_{-1,-2,0} + 16 H_{-1,-1,0,0} + 8 H_{-1,0} \zeta_2 + 6 H_{-1,0,0} - 18 H_{-1,0,0,0} - 4 H_{-1,2,0} - 8 H_{-1,3} - 7 H_0 \zeta_3 + 3/2 H_0 \zeta_2 - 8 H_{0,0} \zeta_2 - 9/2 H_{0,0,0} + 8 H_{0,0,0,0} + 2 H_{3,0} + 6 H_4 \right] - (1+x) \left[4 H_{-2,0} + 8 H_{-1,0,0} \right] + (1-x) \left[4 H_{-3,0} + 4 H_{-2,0,0} - 88/9 H_0 + 3 H_0 \zeta_3 - 28/3 H_{1,0} - 28/3 H_2 \right] - 4 x H_0 \zeta_2 - (50/9 - 184/9 x) H_{0,0} - 4 x H_{0,0} \zeta_2 + (11/2 + 35/2 x) H_{0,0,0} + 8 x H_{0,0,0,0} \right) + 16C_F^2 n_f \left(p_{qq}(x) \left[-11/12 H_0 - 2/3 H_0 \zeta_2 + 11/9 H_{0,0} + 2 H_{0,0,0} + 20/9 H_{1,0} + 4/3 H_{1,0,0} + 20/9 H_2 + 4/3 H_2,0 + 4/3 H_3 \right] - (1+x) H_{0,0,0} + (1-x) \left[13/9 H_0 + 4/3 H_{1,0} + 4/3 H_2 \right] + (8/9 - 28/9 x) H_{0,0} \right).$$

$$\delta P_{ps}^{(2)}(x) \equiv P_{ps}^{(2)T}(x) - P_{ps}^{(2)S}(x) = +8C_A C_F n_f \left(269/6 x^{-1} + 14 + 113/2 x - 346/3 x^2 + \zeta_2(172 + 167x + 8x^2)/3 + \zeta_3(12x^{-1} - 13 + 65x - 28x^2) - 2(1+x) \left[16\zeta_2^2 + 4H_{-1,0,0} + 9H_{3,0} + 4H_{3,1} + 10\zeta_2 H_2 - 12H_{2,0,0} - 2H_{2,1,0} - 6H_{2,2} - H_4 \right] + 8/3(x^{-1} + x^2) \left[4H_{-1,0,0} + \zeta_2 H_0 \right] - 2(1-x) \left[8(H_{-3,0} + H_{-2,0,0}) + 5\zeta_2 H_1 - 9\zeta_2 H_0 + 25/12 H_{1,0} - 6H_{1,0,0} - H_{1,1,0} - 3H_{1,2} + H_{2,1} \right] + 8/3(x^{-1} - x^2) \left[6H_{1,0,0} + H_{1,1,0} + 3H_{1,2} - 5\zeta_2 H_1 - H_2 - H_{2,1} \right] + 2/3(4x^{-1} + 27 - 63x + 28x^2) H_{-2,0} - 2/3(20x^{-1} - 27 + 9x + 56x^2) H_{-1,0} + (89/9 x^{-1} + 55 + 1021/6 x + 2297/18 x^2 - 46\zeta_3 - 22x\zeta_3) H_0 - (8/9 x^{-1} + 293/6 + 370/3 x + 538/9 x^2 + 2\zeta_2(1-7x)) H_{0,0} - 32x H_{0,0,0,0} + (5 - 16/3 x^{-1} + 85x) H_{0,0,0} - 1/6(115x^{-1} + 362 - 292x - 185x^2) H_1 - (6x^{-1} + 48 + 59x + 22x^2) H_2 - 2(5 + x - 8/3 x^2) H_{2,0} + 4(2/3 x^{-1} + x + 2x^2) H_3 \right) + 8C_A C_F n_f^2 \left(-217/18 - 55/3 x^{-1} + 122/9 x + 101/6 x^2 + \zeta_3(16x^{-1} + 36 + 24x) - \zeta_2(127 + 188x + 128x^2)/3 + 2(1+x) \left[16\zeta_2^2 + 17\zeta_2 H_0 + 8\zeta_2 H_1 - 7\zeta_2 H_{0,0} + 10\zeta_2 H_2 + 9H_{2,0} - 12H_{2,0,0} - 2H_{2,1,0} - 6H_{2,2} + 9H_{3,0} + 4H_{3,1} - H_4 \right] + 2(1-x) \left[5\zeta_2 H_1 + 2H_{2,0} + 139/12 H_{1,0} - 6H_{1,0,0} - H_{1,1,0} - 3H_{1,2} + H_{2,1} \right] + 8/3(x^{-1} - x^2) \left[5\zeta_2 H_1 + 5/3 H_{1,0} - 6H_{1,0,0} - H_{1,1,0} - 3H_{1,2} + 2H_{2,0} + H_{2,1} \right] - (527 + 2473x + 811x^2 + 72\zeta_2)/18 H_0 + (62 + 81/2 x + 208/9 x^2) H_{0,0} + (6 + 18x - 8x^2) H_{0,0,0} + (385/18 x^{-1} + 190/3 - 143/3 x - 667/18 x^2) H_1 + (28/9 x^{-1} + 71 + 46x + 248/9 x^2) H_2 - 4/3(4x^{-1} - 6 - 3x + 8x^2) H_3 \right) + 8C_F n_f^2 \left(2/9(23x - 2x^{-1} - 20 - x^2) + 2(1+x) \left[\zeta_3 - \zeta_2 H_0 - H_1 + H_{2,0} + H_3 - H_{0,0,0} \right] - (1-x) \left[H_1 - H_{1,0} \right] + 4/3(x^{-1} - x^2) H_{1,0} + 2/9(3 + 18x + 10x^2) H_0 - (7 + x - 4x^2)/3 H_{0,0} - (20x^{-1} - 56x^2)/9 H_1 + (3 + 7x + 8/3 x^2) (\zeta_2 - H_2) \right).$$

$$\delta P_{gg}^{(2)}(x) \equiv P_{gg}^{(2)T}(x) - P_{gg}^{(2)S}(x) = +16C_A^2 \left(p_{gg}(x) \left[(1025/54 - 11/3 \zeta_2 - 2\zeta_3) H_0 - 49/3 H_{0,0} - 33 H_{0,0,0} + 16 H_{0,0,0,0} - (268/9 - 8\zeta_2) (H_{1,0} + H_2) - 44/3 (H_{1,0,0} + H_{2,0} + H_3) + 12 H_{1,0,0,0} + 4 H_{2,0,0} + 4 H_{3,0} + 12 H_4 \right] + p_{gg}(-x) \left[+16 H_{-3,0} - 16 \zeta_2 H_{-2} - 16 H_{-2,-1,0} - 22/3 H_{-2,0} + 28 H_{-2,0,0} + 8 H_{-2,2} - 16 H_{-1,-2,0} - 32 H_{-1,-1,0,0} - 16 \zeta_2 H_{-1,0} - 44/3 H_{-1,0,0} + 36 H_{-1,0,0,0} + 8 H_{-1,2,0} + 16 H_{-1,3} + (14\zeta_3 - 11/3 \zeta_2) H_0 + 16 \zeta_2 H_{0,0} + 11 H_{0,0,0} - 16 H_{0,0,0,0} - 4 H_{3,0} - 12 H_4 \right] + (1+x) \left[-24 H_{-2,0} - 48 H_{-1,0,0} + 14/3 H_2 + 28/3 H_3 \right] + (1-x) \left[32(H_{-3,0} + H_{-2,0,0}) - (881/36 - 24\zeta_3) H_0 - 27(H_{1,0} + H_2) - 44/3(x^{-1} + x^2) \left[2H_{-2,0} + 4H_{-1,0,0} - H_{2,0} - 2H_3 \right] + (x^{-1} - x^2) \left[+2261/54 H_0 + 134/9(H_{1,0} + H_2) \right] - (44x^{-1} + 86 + 14x + 132x^2)/3 \zeta_2 H_0 + (536x^{-1} + 425 + 515x + 752x^2 + 288\zeta_2)/9 H_{0,0} + (88x^{-1} - 10 + 8x + 44x^2) H_{0,0,0} + 64x H_{0,0,0,0} \right) + 16C_A^2 n_f \left(p_{gg}(x) \left[- (158/27 - 2/3 \zeta_2) H_0 - 4/9 H_{0,0} + 6 H_{0,0,0} + 40/9 (H_{1,0} + H_2) + 8/3 (H_{1,0,0} + H_{2,0} + H_3) \right] + 2/3 p_{gg}(-x) \left[2H_{-2,0} + 4H_{-1,0,0} + \zeta_2 H_0 - 3H_{0,0,0} \right] - \frac{4}{3}(1+x) \left[\zeta_2 H_0 - H_{2,0} - 2H_3 \right] - (1-x) \left[173/9 H_0 + 2(H_{1,0} + H_2) \right] + (x^{-1} - x^2) \left[913/54 H_0 + 26/9 (H_{1,0} + H_2) \right] + 4/9(35x^{-1} + 21 + 48x) H_{0,0} + 4(1 + 4x) H_{0,0,0} \right) + \frac{16}{27} C_A n_f^2 \left(p_{gg}(x) \left[10 H_0 + 12 H_{0,0} \right] + 12(1+x) H_{0,0} + (13(x^{-1} - x^2) - 9 + 9x) H_0 \right).$$

$$+8C_A C_F n_f \left(-2p_{gg}(x) H_0 - 269/6 x^{-1} - 14 - 113/2 x + 346/3 x^2 - \zeta_2(172 + 167x + 8x^2)/3 + \zeta_3(12x^{-1} - 13 + 65x - 28x^2) + 2(1+x) \left[16\zeta_2^2 + 2H_{-2,0} - 4H_{-1,0,0} + 17\zeta_2 H_0 + 4/3 \zeta_2 H_1 - 3\zeta_2 H_{0,0} + 10\zeta_2 H_2 - 12H_{2,0,0} - 2H_{2,1,0} - 6H_{2,2} + 4H_{3,1} + 9H_{3,0} - H_4 \right] + 8/3(x^{-1} + x^2) \left[4H_{-1,0,0} + \zeta_2 H_0 \right] - 2(1-x) \left[8(H_{-3,0} + H_{-2,0,0}) + 18H_{-2,0} + 9\zeta_2 H_0 + 6\zeta_2 H_1 + 4\zeta_2 H_{0,0} - 145/12 H_{1,0} \right] + \left[\frac{8}{3}(x^{-1} - x^2) + 2(1-x) \right] \left[3H_{-2,0} - 11/3 H_{1,0} + 5\zeta_2 H_1 - 6H_{1,0,0} - H_{1,1,0} - 3H_{1,2} + H_{2,1} \right] + (40x^{-1} - 54 + 18x + 112x^2)/3 H_{-1,0} - (59x^{-1} + 45 + 1081/6 x + 157/2 x^2) H_0 - (464x^{-1} + 329/2 - 146x - 66x^2)/9 H_{0,0} - (80/3 x^{-1} - 17 + 15x) H_{0,0,0} - 32x H_{0,0,0,0} + (115x^{-1} + 362 - 292x - 185x^2)/6 H_1 - 1/9(34x^{-1} - 546 - 417x - 286x^2) H_2 + (8x^{-1} + 10 - 14x - 24x^2)/3 H_{2,0} - 8/3(x^{-1} + 5 + 13/2 x + 3x^2) H_3 \right) + 8C_F^2 n_f \left(217/18 + 55/3 x^{-1} - 122/9 x - 101/6 x^2 - \zeta_3(16x^{-1} + 36 + 24x) + \zeta_2/3(127 + 188x + 128x^2) - 2(1+x) \left[16\zeta_2^2 + \zeta_2 H_0 + 10\zeta_2 H_2 + 17\zeta_2 H_3 - 12H_{2,0,0} - 2H_{2,1,0} - 6H_{2,2} + 9H_{3,0} + 4H_{3,1} - H_4 \right] - \left[\frac{8}{3}(x^{-1} - x^2) + 2(1-x) \right] \left[5\zeta_2 H_1 + 3H_{1,0} - 6H_{1,0,0} - 3H_{1,2} - H_{1,1,0} + H_{2,1} \right] + (4x^{-1} + 283/6 + 239/2 x + 739/18 x^2 - 8\zeta_2 - 20\zeta_2 x - 16/3 \zeta_2 x^2) H_0 - (18 + 97/2 x + 16x^2) H_{0,0} - (6 - 6x + 8x^2) H_{0,0,0} - (385x^{-1} + 1140 - 858x - 667x^2)/18 H_1 + 53/6(1-x) H_{1,0} - (20/3 x^{-1} + 45 + 72x + 24x^2) H_2 - (32/3 x^{-1} + 14 + 6x) H_{2,0} - (16/3 x^{-1} - 8 - 12x) H_3 \right) + 8/9 C_F n_f^2 \left(4x^{-1} + 40 - 46x + 2x^2 - 9\zeta_2(3 + 7x + 8/3 x^2) - 6(1+x) \left[3\zeta_3 + \zeta_2 H_0 + 3H_{0,0,0} - H_{2,0} - 5H_3 \right] - (92/3 x^{-1} - 6 + 48x - 32/3 x^2) H_0 - (16x^{-1} + 83 + 101x + 28x^2) H_{0,0} + (20x^{-1} + 27 + 9x - 56x^2) H_1 + (4x^{-1} + 3 - 3x - 4x^2) H_{1,0} + (16x^{-1} + 39 + 51x + 8x^2) H_2 \right).$$

S.M., Vogt '07
2007

The Trouble With QCD

FACTORISATION

SPLIT THE THEORY INTO PARTS;
SHORT DISTANCES WHERE PREDICTIONS CAN
BE MADE

LARGE DISTANCES WHERE APPROXIMATIONS
HAVE TO BE MADE

QUARKS MUST FRAGMENT INTO
HADRONS WITH UNIT PROBABILITY

CONFINEMENT HAPPENS IN THE REGION WHERE
PERTURBATION THEORY FAILS

WE HAVE TO USE MODELS OF WHAT WE THINK IS
HAPPENING BUT BASED ON QCD. THESE MODELS
CAN HAVE DIFFERENT ASSUMPTIONS AND A
VARIETY OF PARAMETERS.

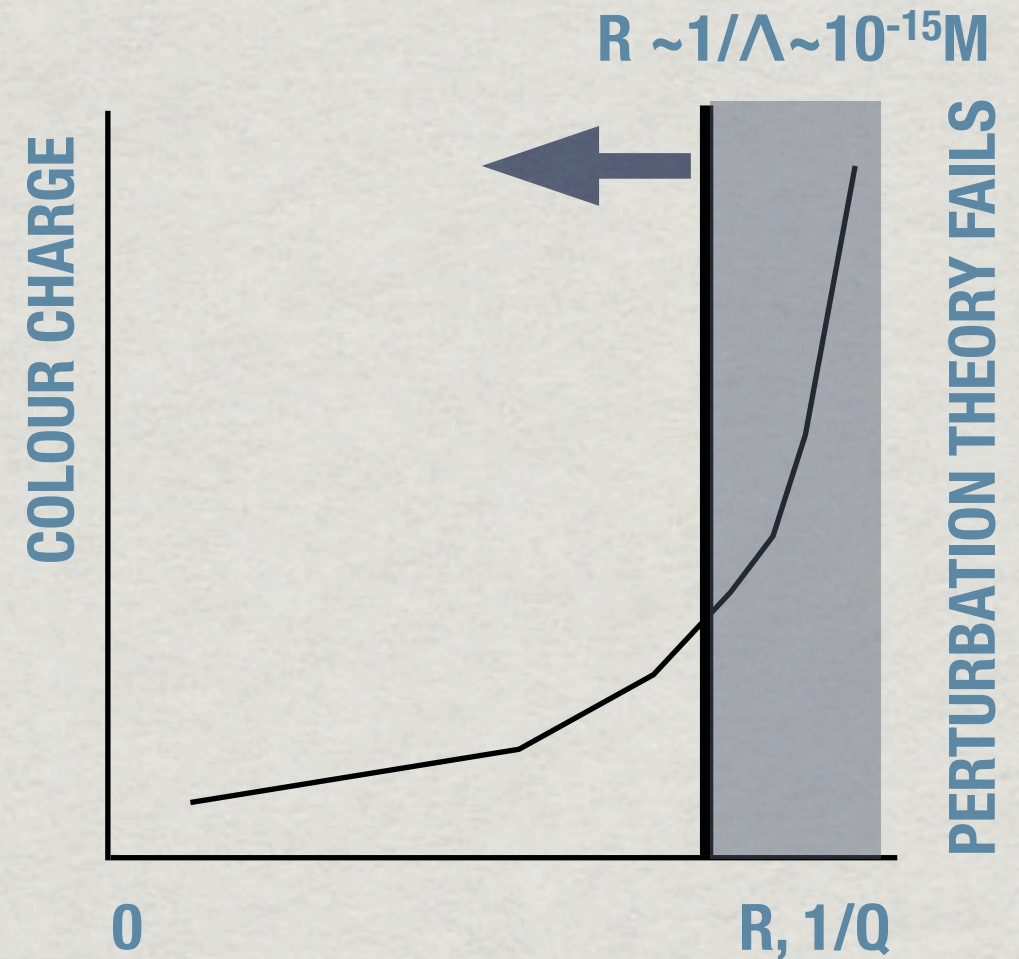

THESE ASSUMPTIONS AND
PARAMETERS NEED TO BE
CONFRONTED WITH AND TUNED TO
DATA

Working QCD Model

STARTING SCALE
GIVEN BY HARD
SCALE Q

PROBABILITY OF PARTON EMISSION
GIVEN BY THE "QCD" SPLITTING
FUNCTIONS, REDUCING Q

AT SOME FIXED VALUE "Q₀" THE
EVOLUTION IS STOPPED AND
THE PARTONS ARE HADRONISED

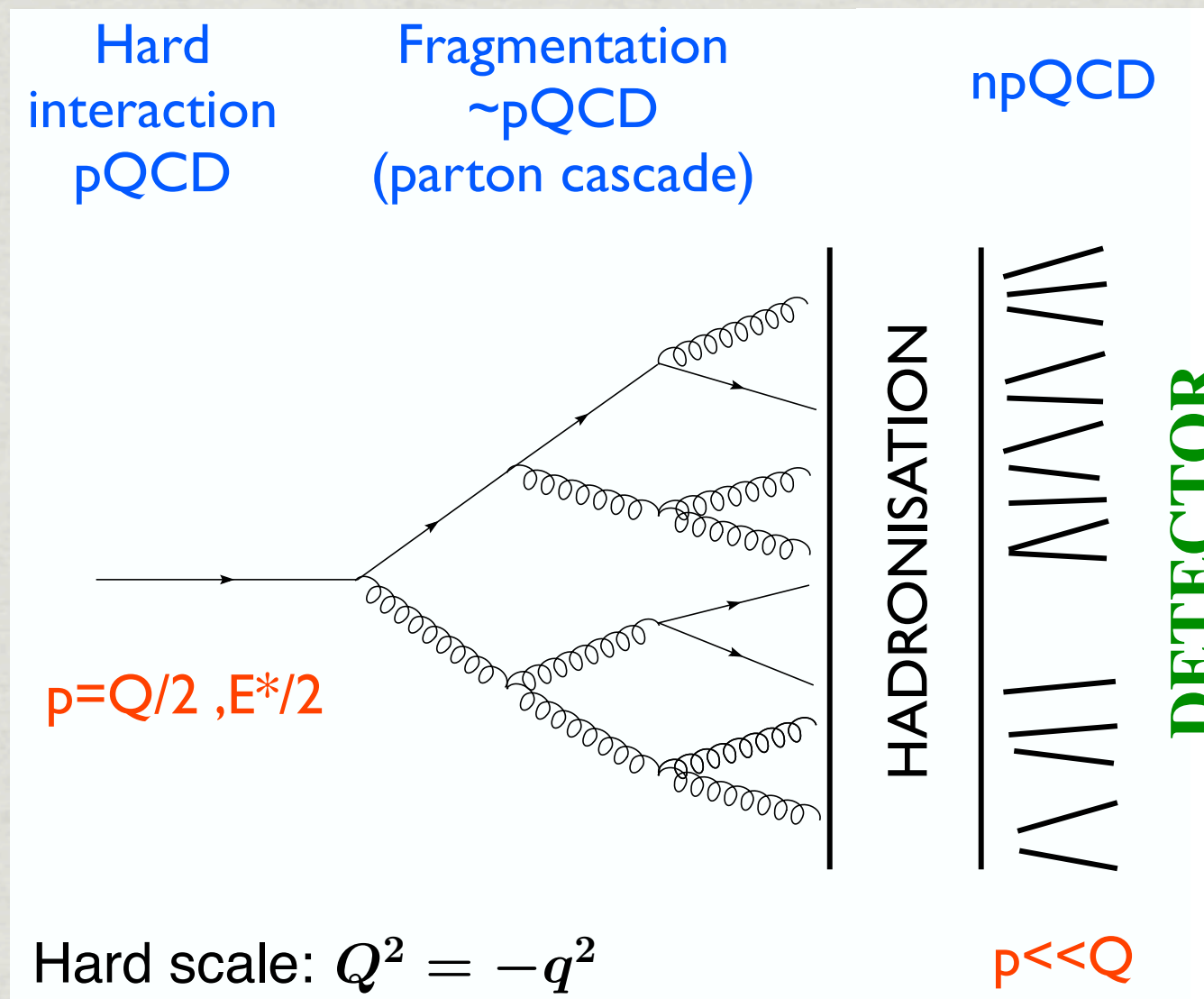

LO , NLO ME

DGLAP, BFKL, CCFM, MLLA ETC..

LPHD, STRING, CLUSTER

Universality of Fragmentation

VACUUM

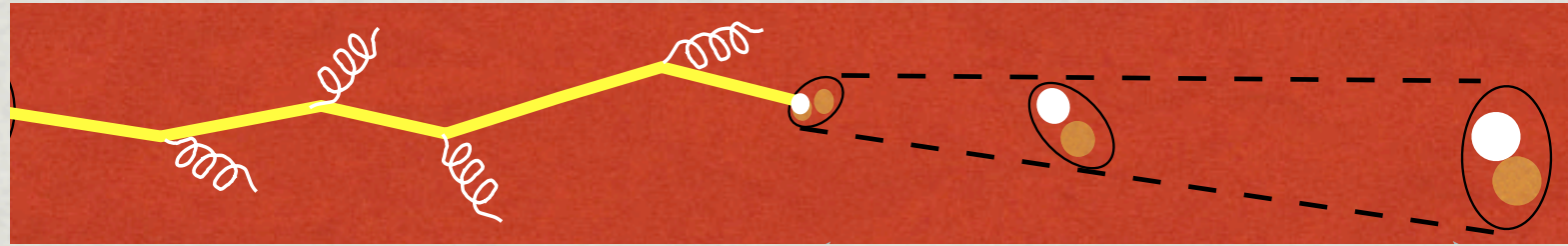

PETRA,
SLC,LEP

COMPLEXITY



MEDIUM

Universality of Fragmentation

VACUUM

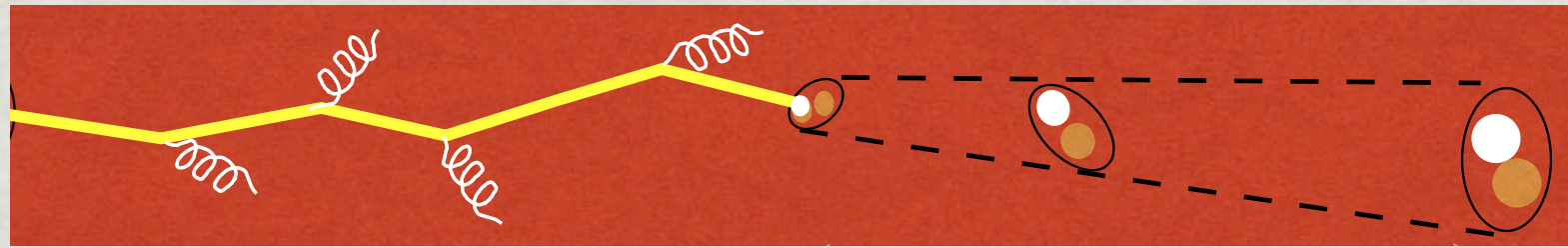

PETRA,
SLC,LEP

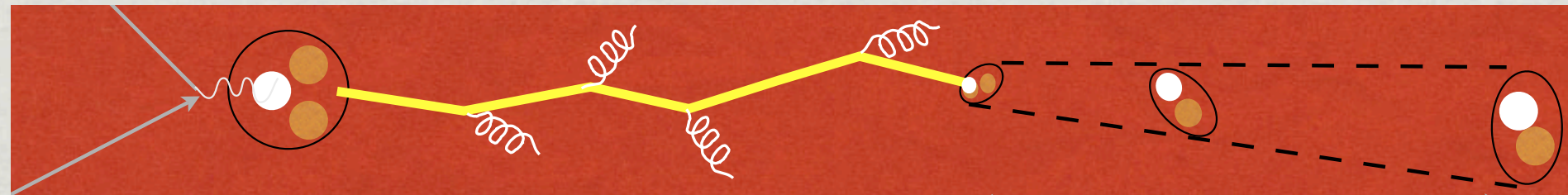

HERA

COMPLEXITY



MEDIUM

Universality of Fragmentation

VACUUM

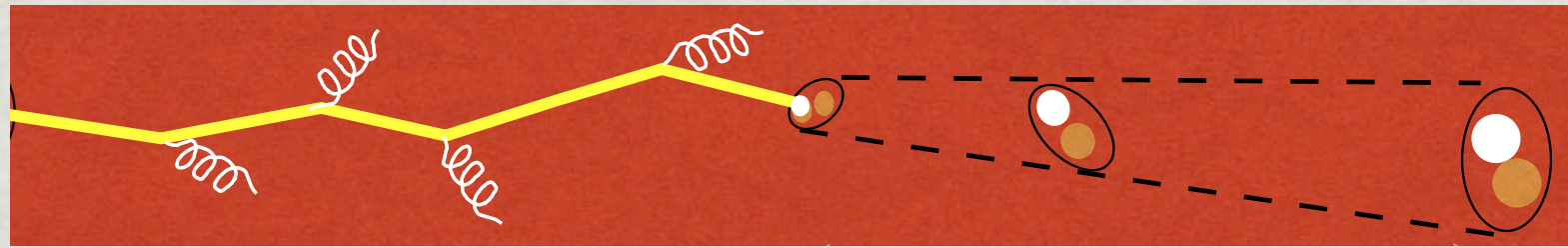

PETRA,
SLC,LEP

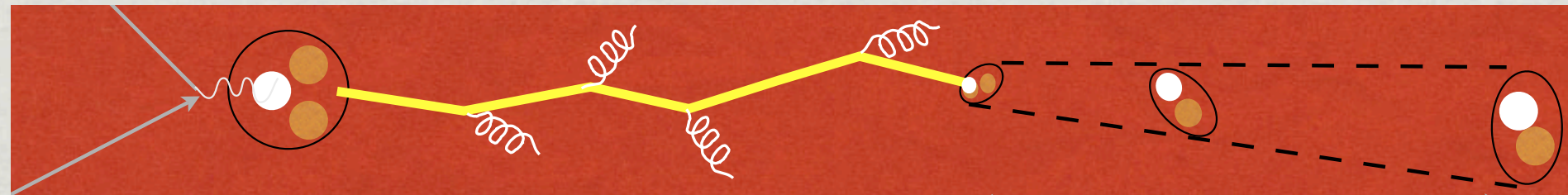

HERA

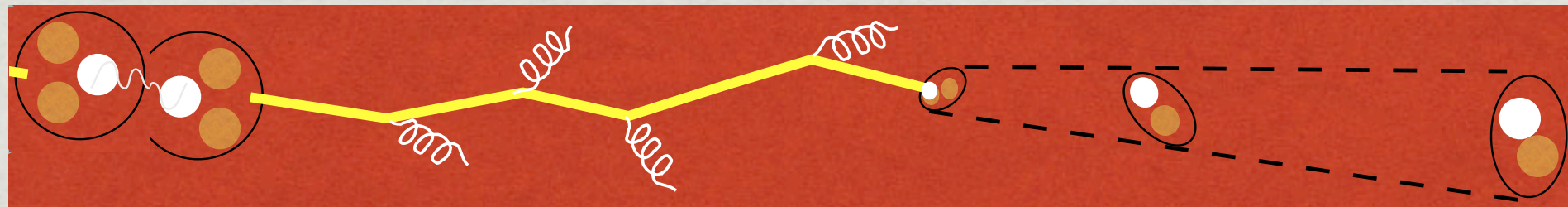

TEVATRON
RHIC,LHC

COMPLEXITY

MEDIUM

Universality of Fragmentation

VACUUM

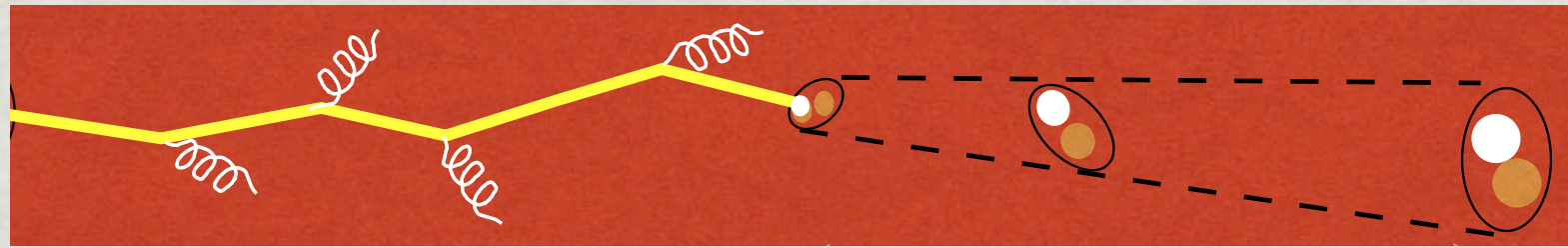

PETRA,
SLC,LEP

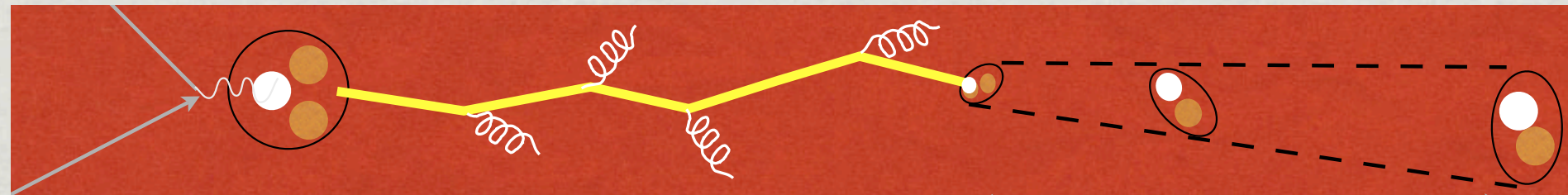

HERA

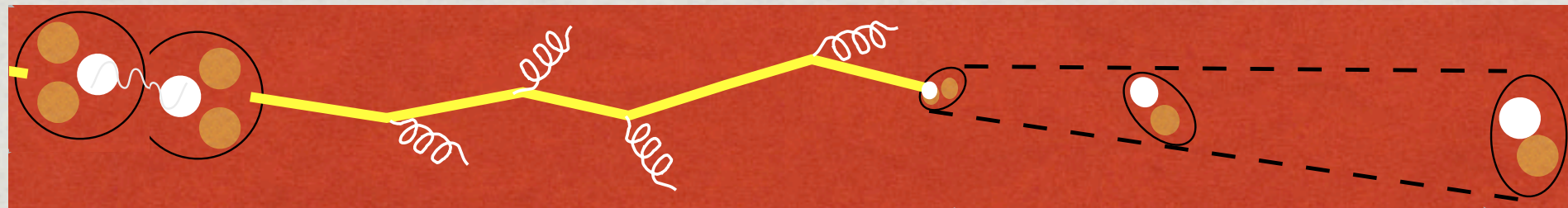

TEVATRON
RHIC,LHC

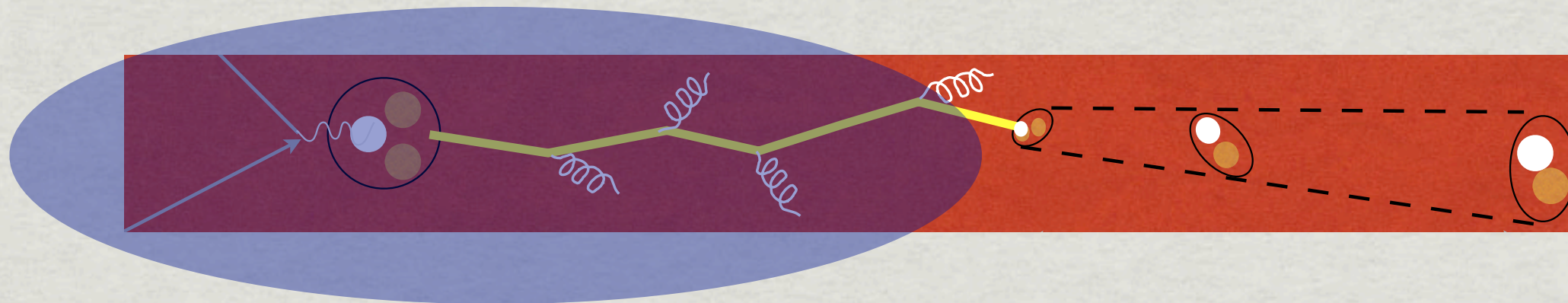

HERMES
CLAS

COMPLEXITY

MEDIUM

Universality of Fragmentation

VACUUM

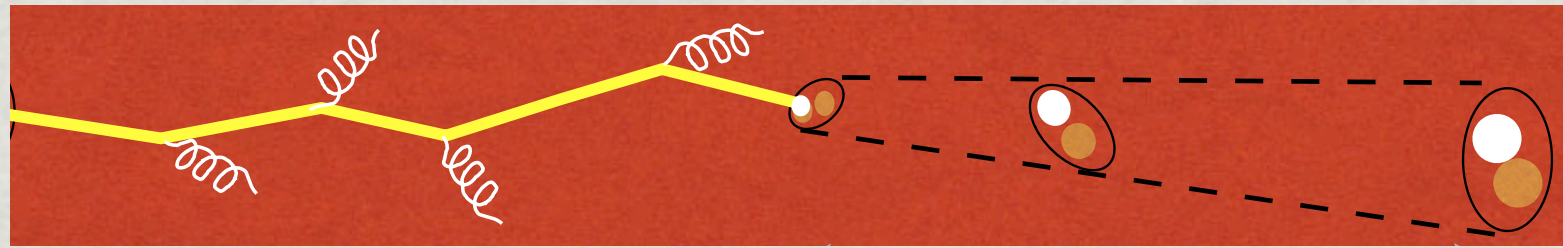

PETRA,
SLC,LEP

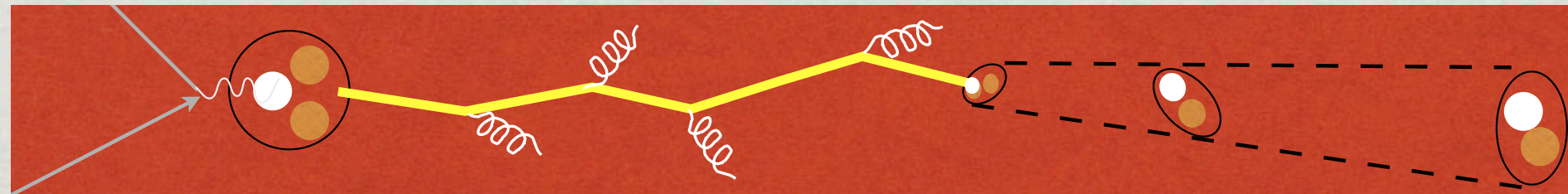

HERA

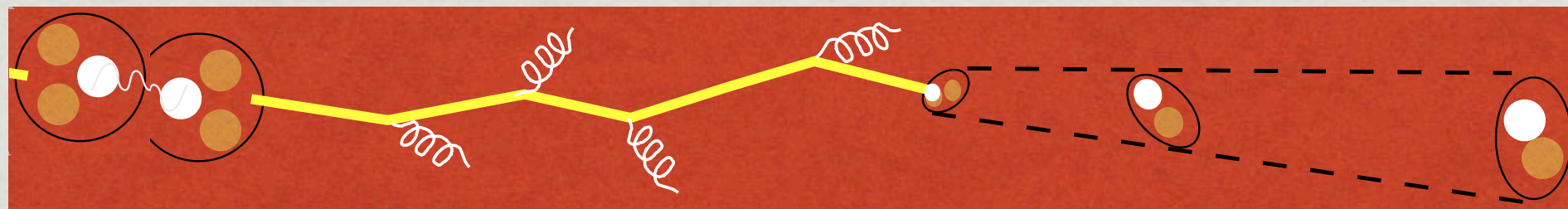

TEVATRON
RHIC,LHC

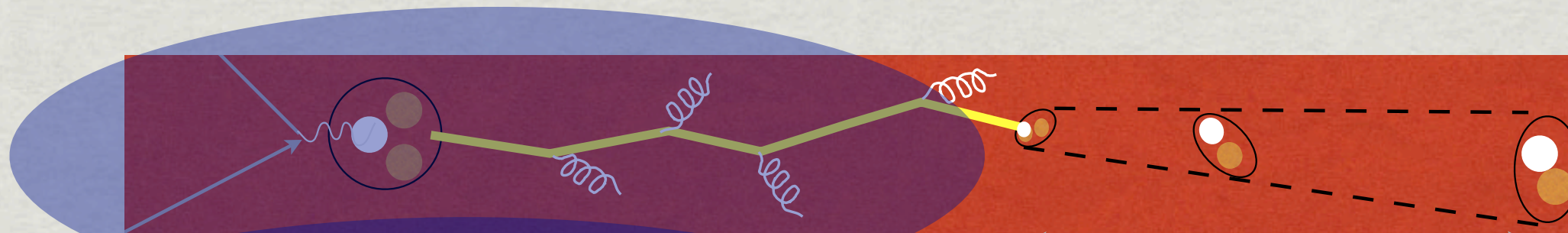

HERMES
CLAS



RHIC
LHC

COMPLEXITY

MEDIUM

HERA & Hamburg

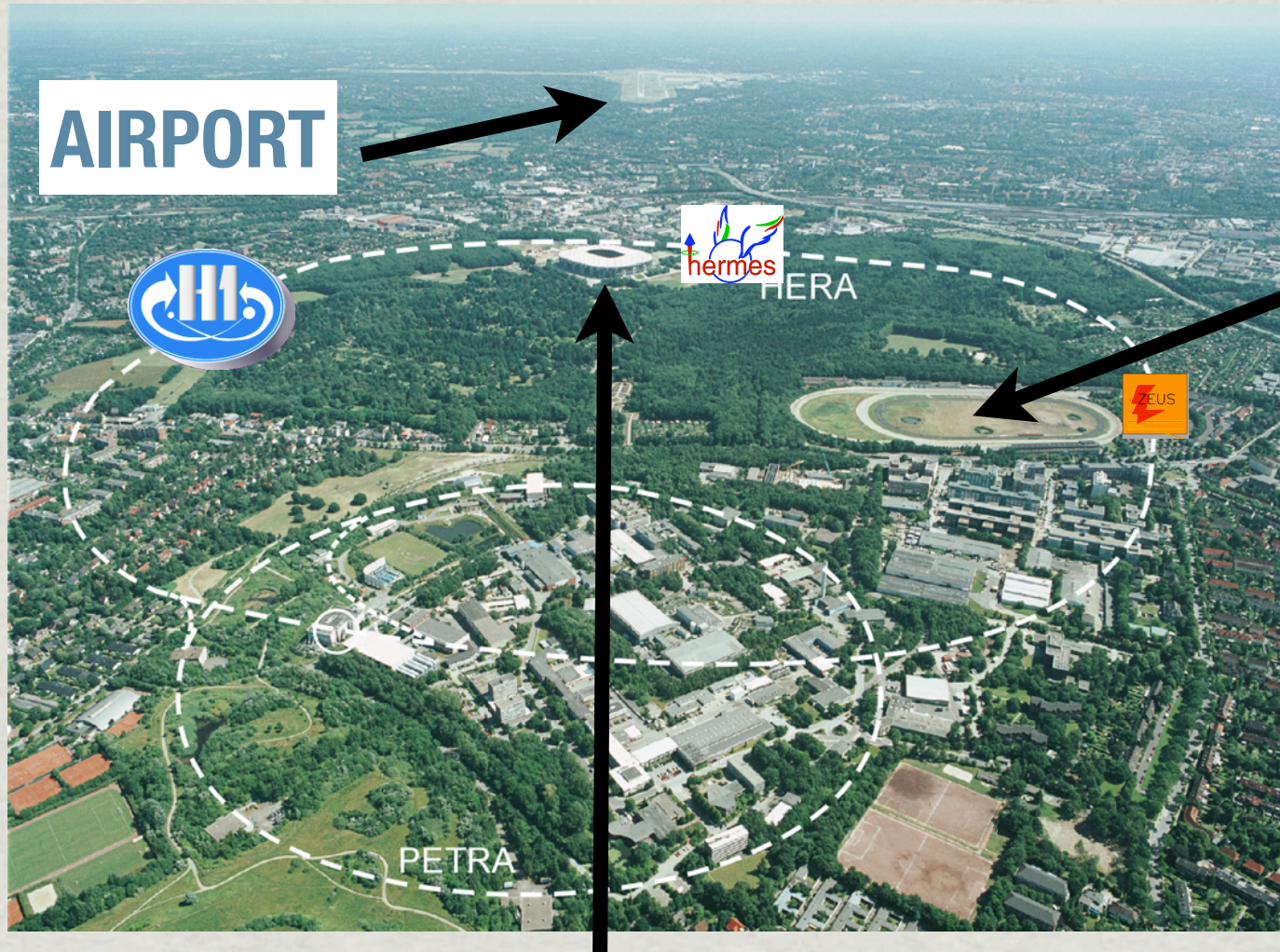

TRABRENNEN



HSV STADIUM

HERA & Hamburg

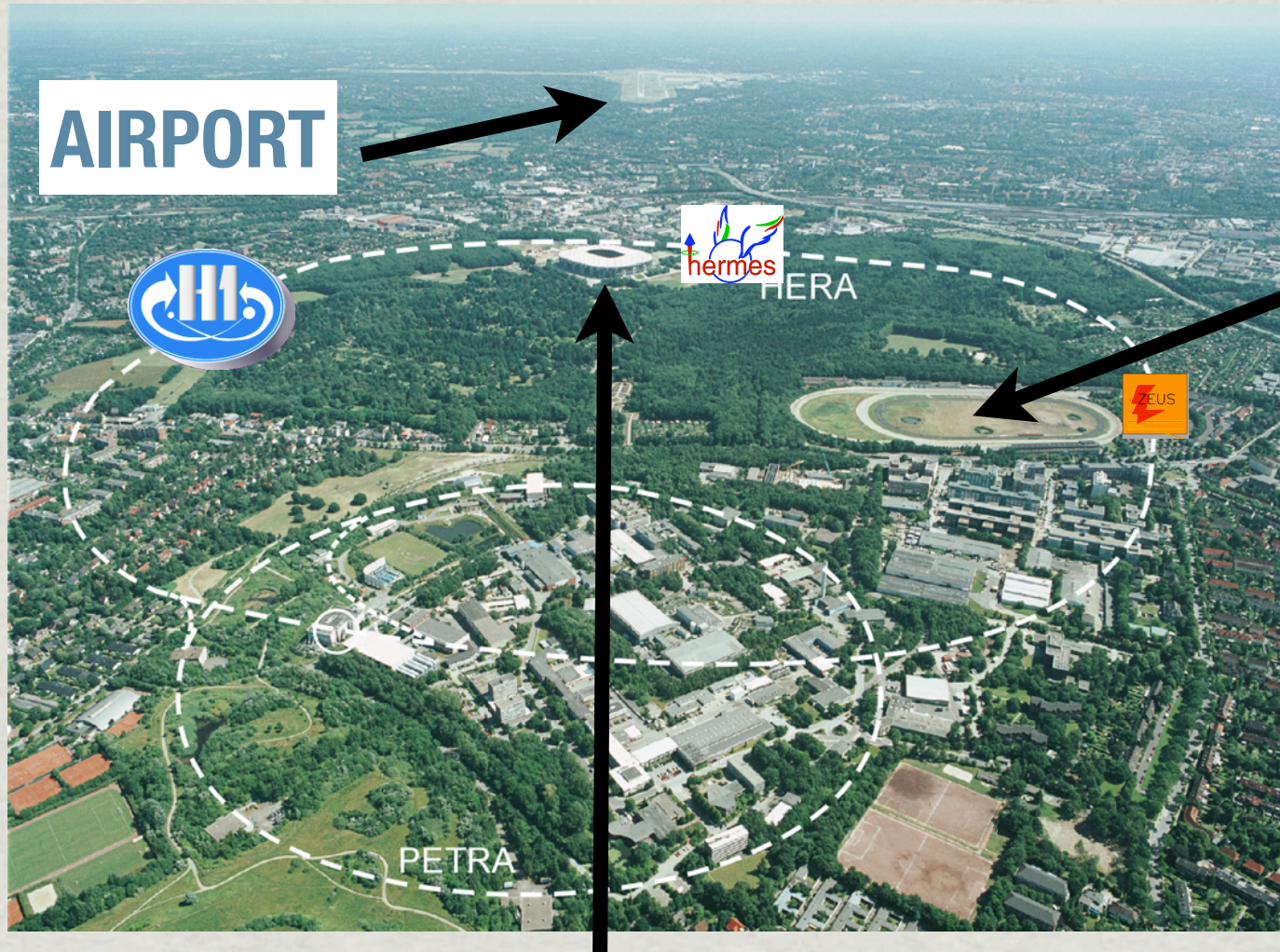

TRABRENNEN



HSV STADIUM

HERA & Hamburg

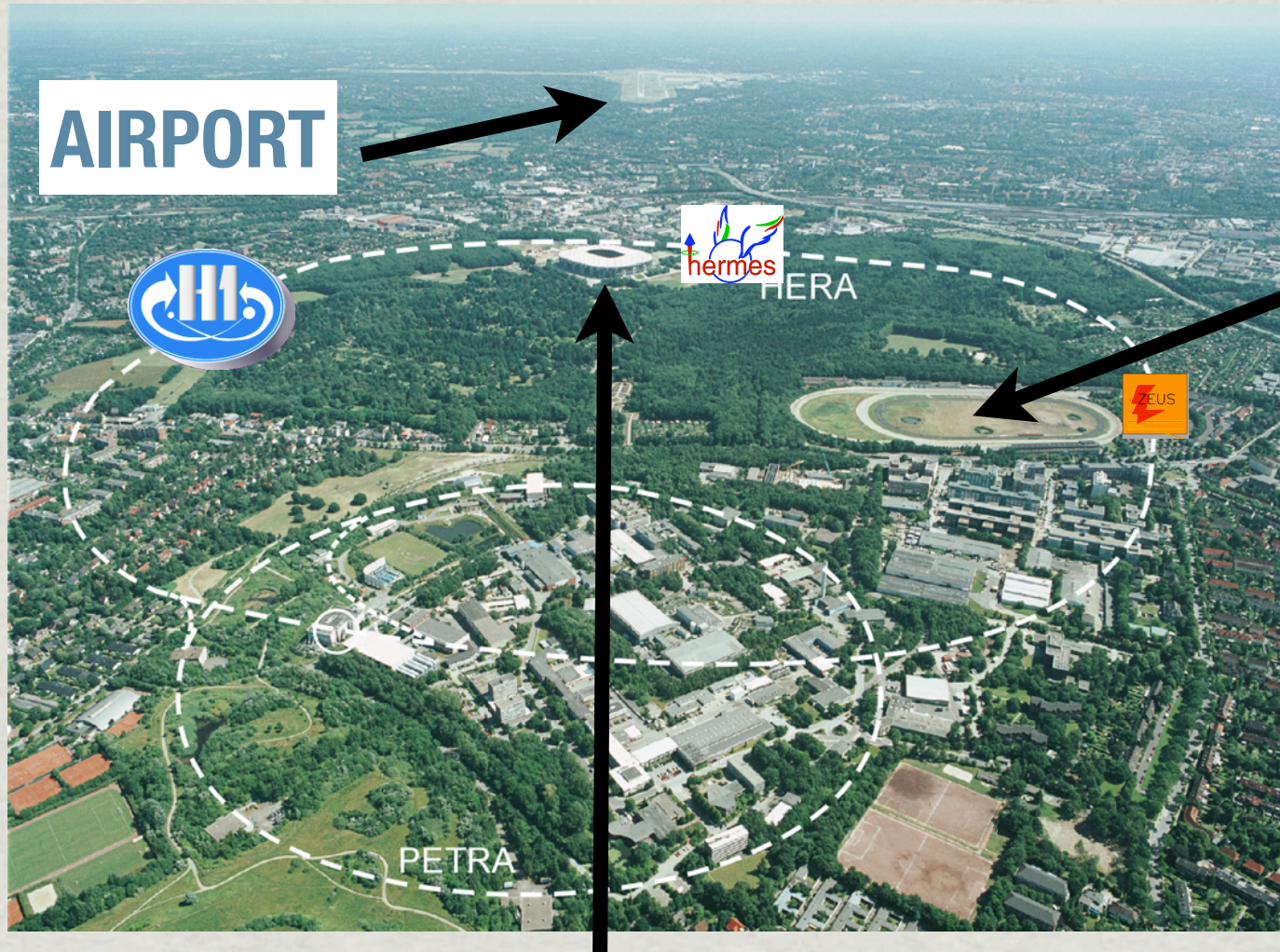

TRABRENNEN



HSV STADIUM

HERA & Hamburg

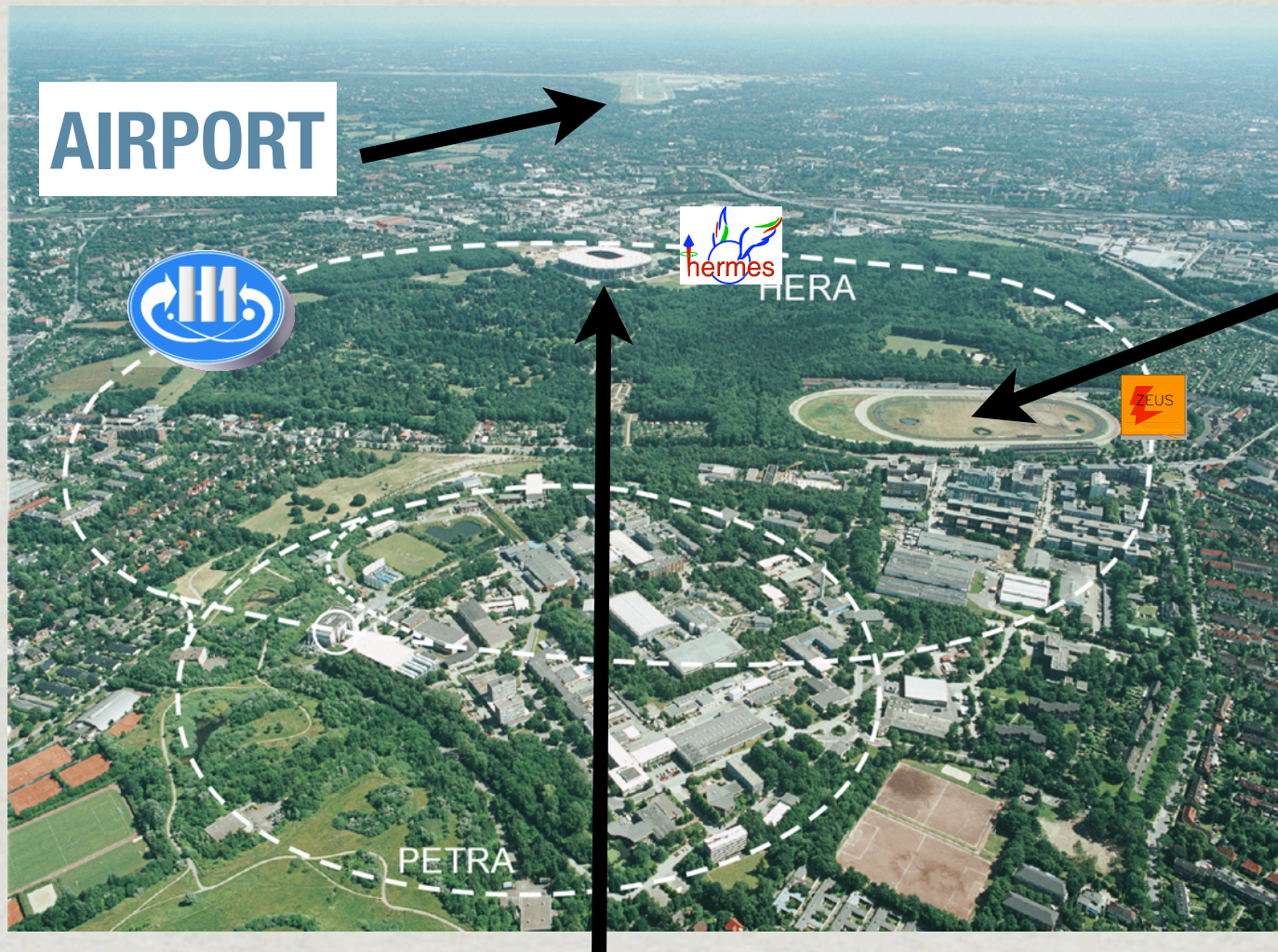

TRABRENNEN



HSV STADIUM



HERA machine & physics

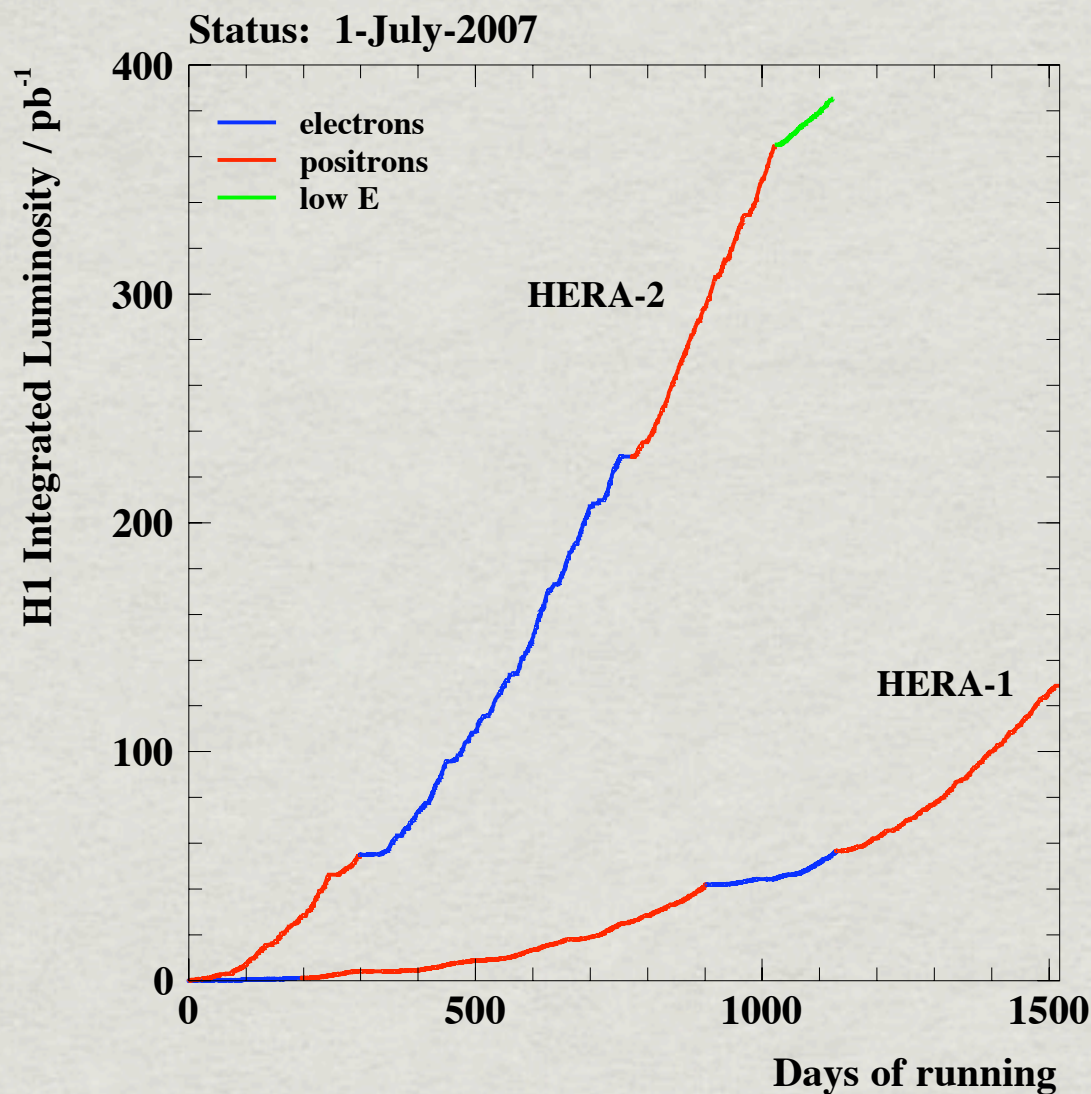
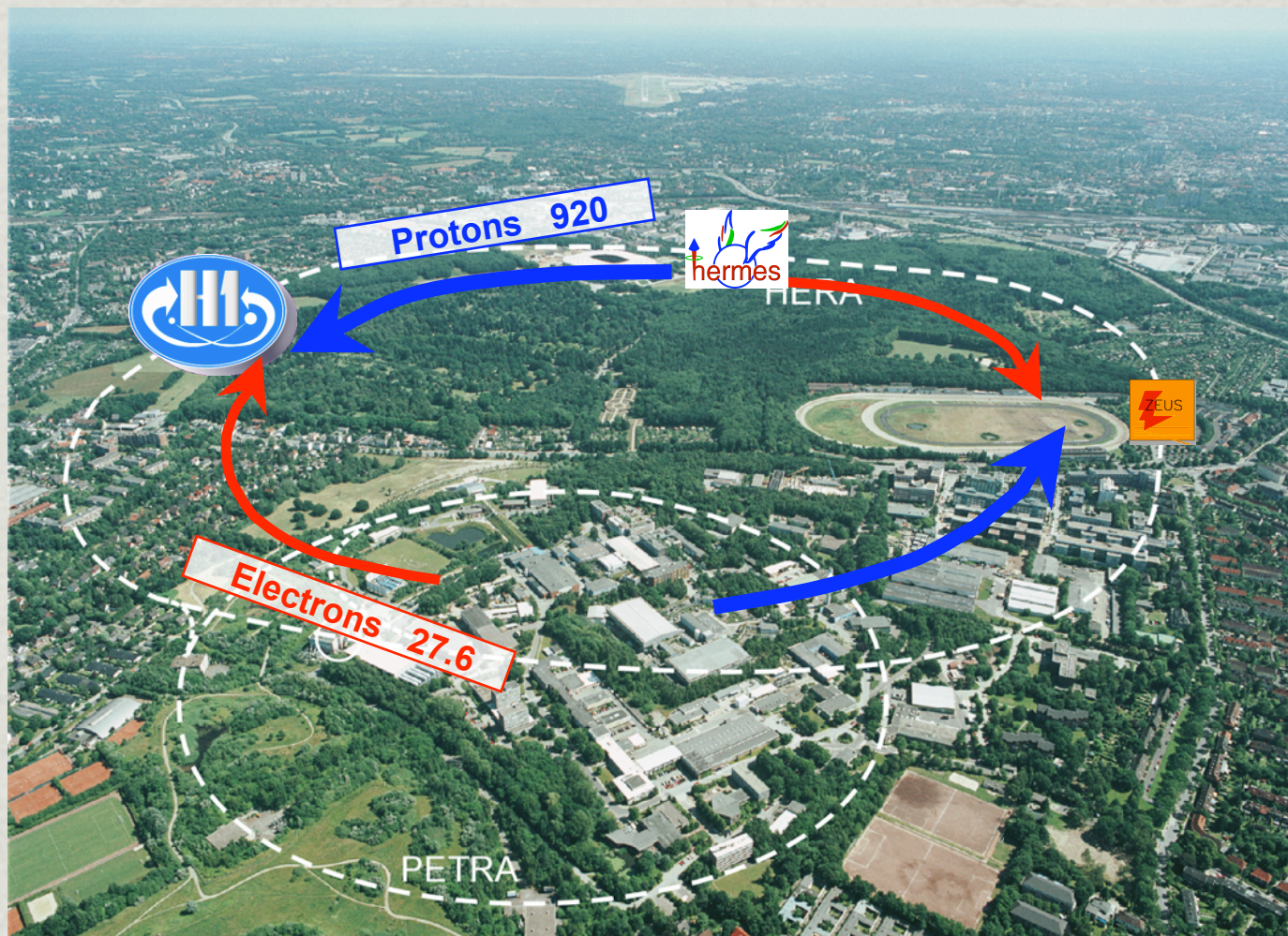

1992 - 2007

$\sim 0.5 \text{ fb}^{-1}$ PER EXPERIMENT

+ LOW ENERGY PROTON RUN TO MEASURE F_L

The H1 Detector

ASYMMETRIC BEAM ENERGIES =
ASYMMETRIC DETECTOR

920 GEV
PROTONS

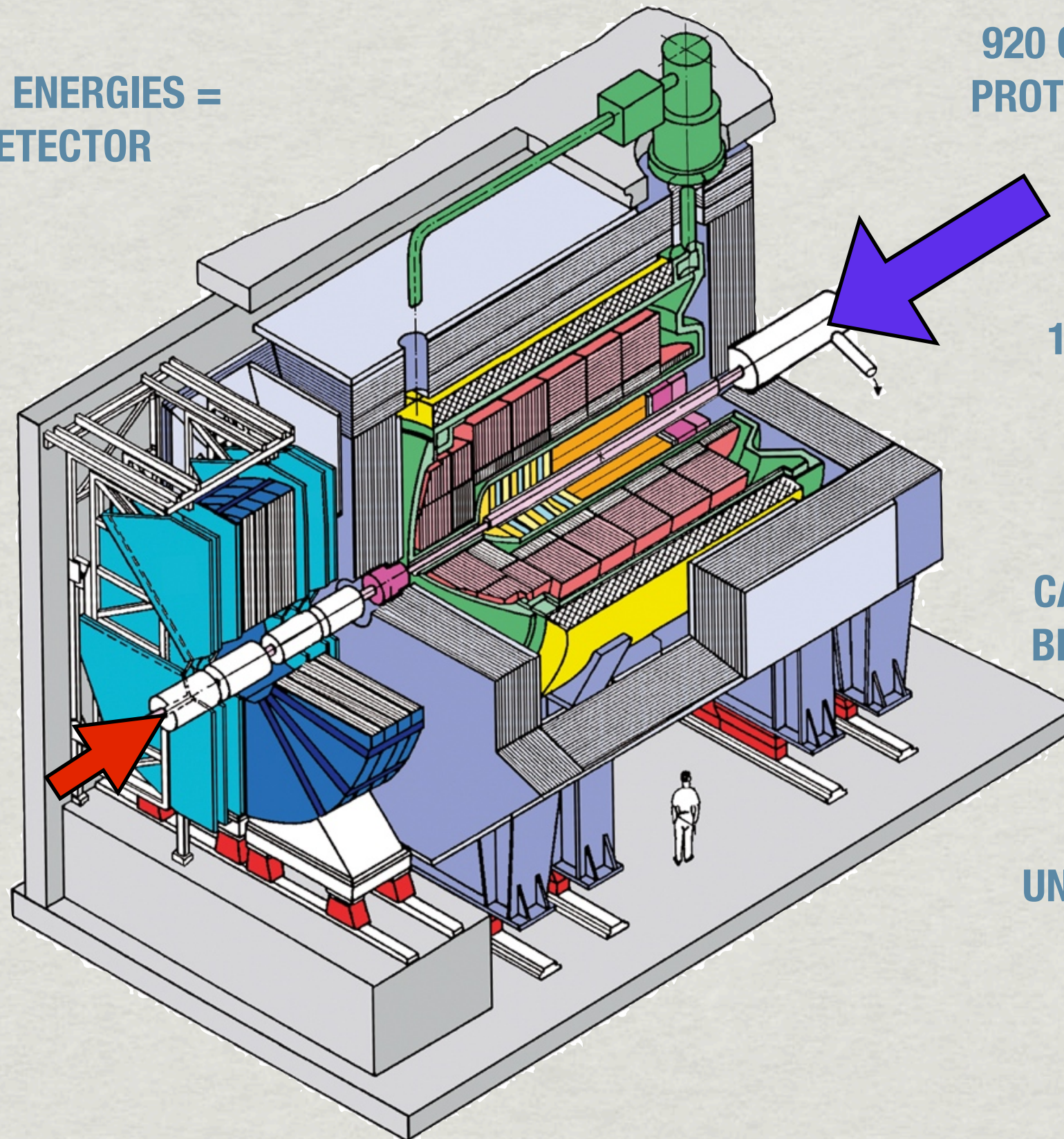

1.16 T SOLENOID,
RADIUS 2.7 M
(ALEPH LIKE)

COIL OUTSIDE
CALORIMETER FOR
BEST RESOLUTION!

27.5 GEV
ELECTRONS

UNIFORM FIELD FOR
TRACKING
(CENTRAL AND
FORWARD)!

The H1 Detector

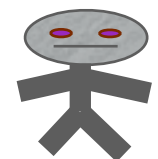
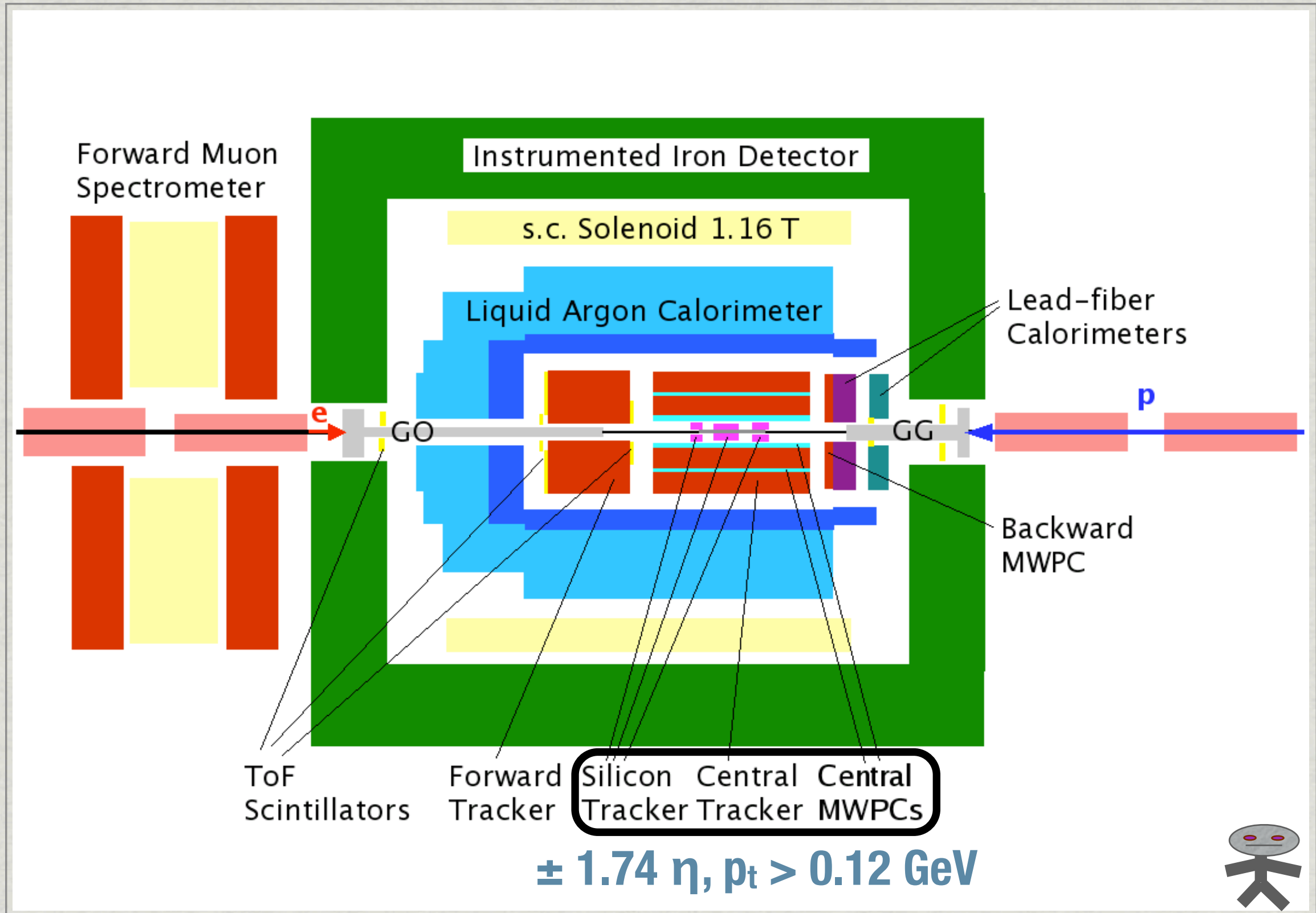

DIS

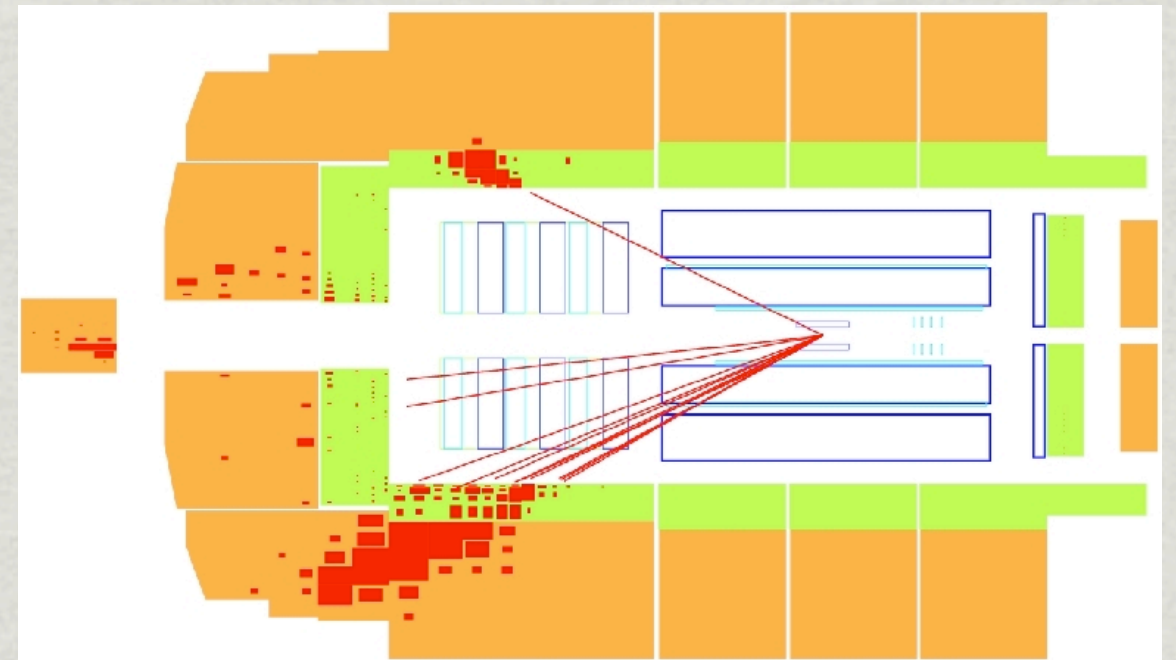
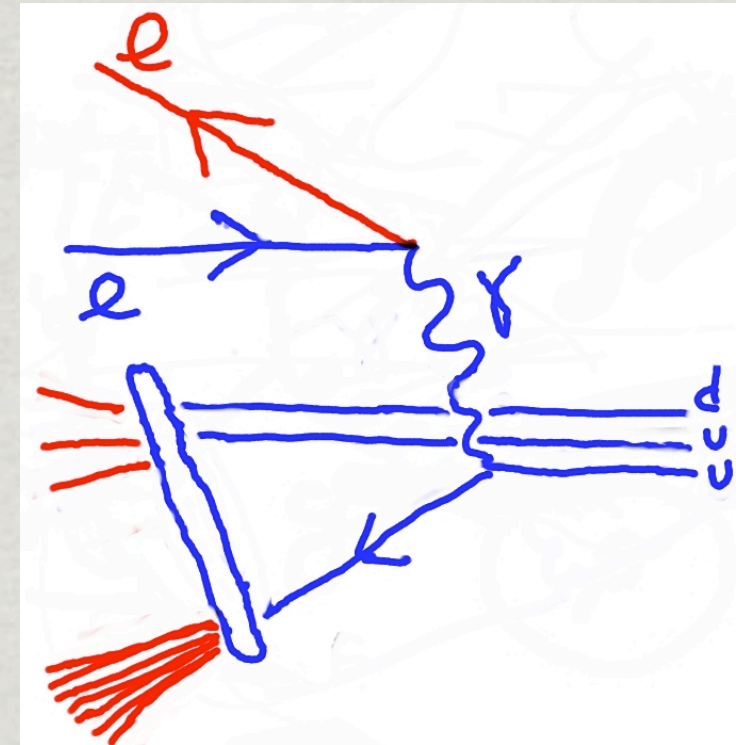
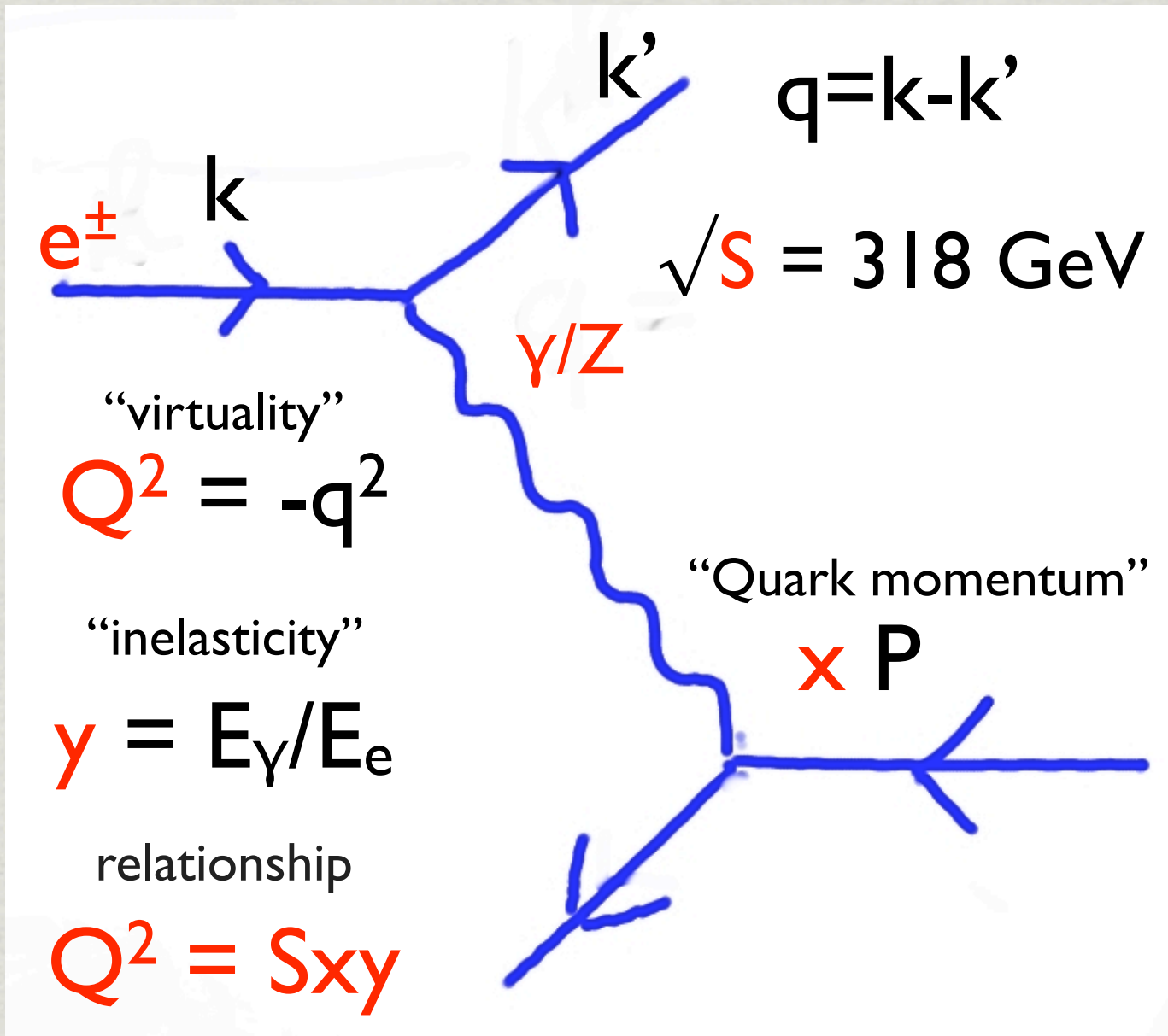

DIS, BORN LEVEL

Fragmentation Functions

Fragmentation Function

$$x_p = \frac{(2P_h)}{Q}$$

$$D(x_p) = \frac{1}{N_{event}} \frac{dn}{dx_p}$$

x_p = SCALED MOMENTUM VARIABLE

$Q/2$ = SCALE IN CURRENT REGION OF BREIT FRAME

P_H = MOMENTUM OF CHARGED PARTICLE IN CURRENT REGION OF BREIT FRAME

$D(x_p)$ = EVENT NORMALISED, CHARGED PARTICLE, SCALED MOMENTUM DISTRIBUTION

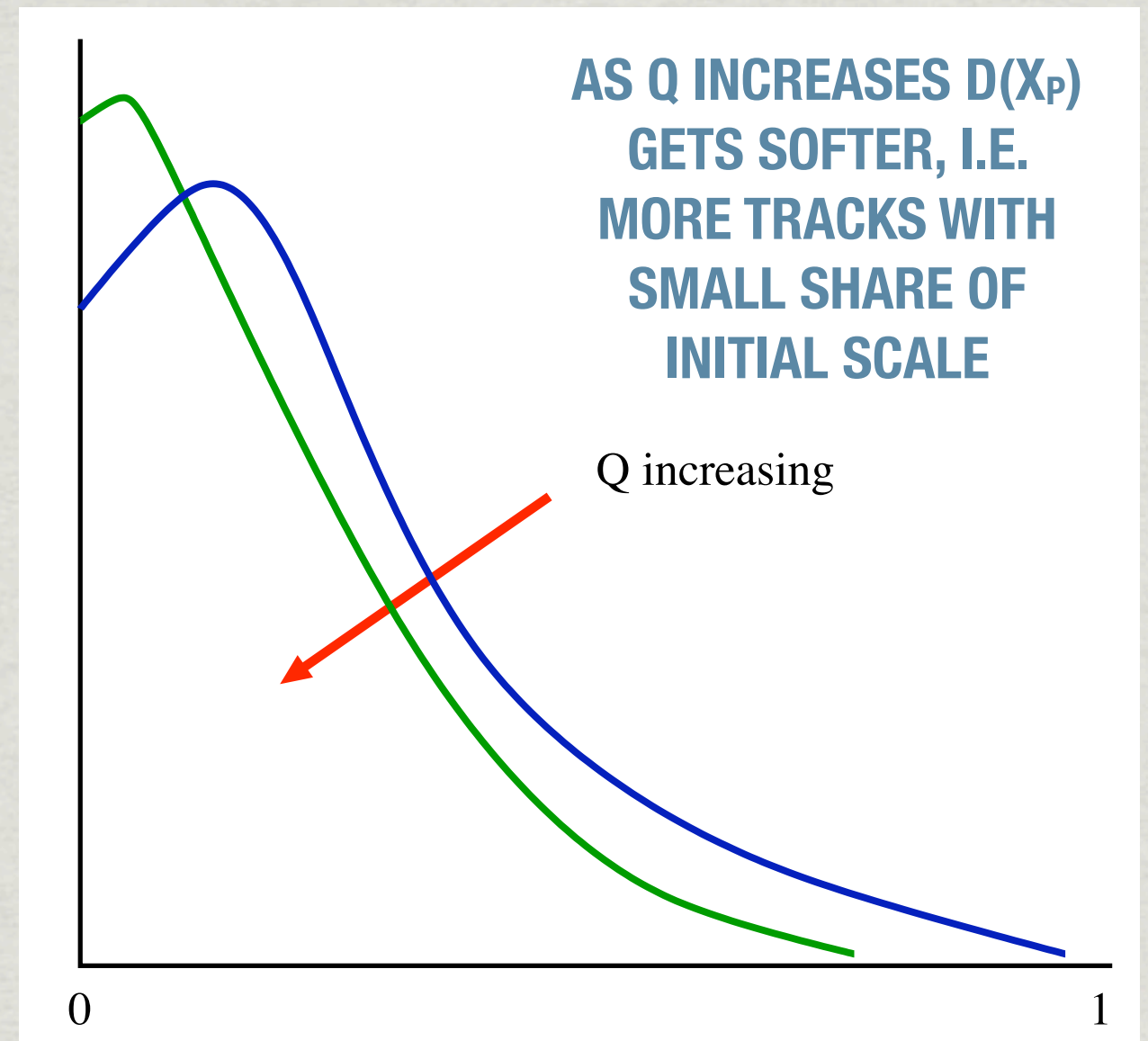

Scaling Violations

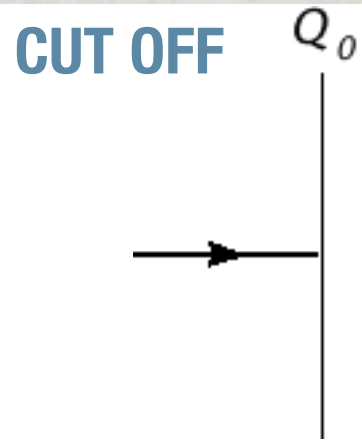

$Q \sim Q_0$, NO ROOM FOR
GLUON EMISSION

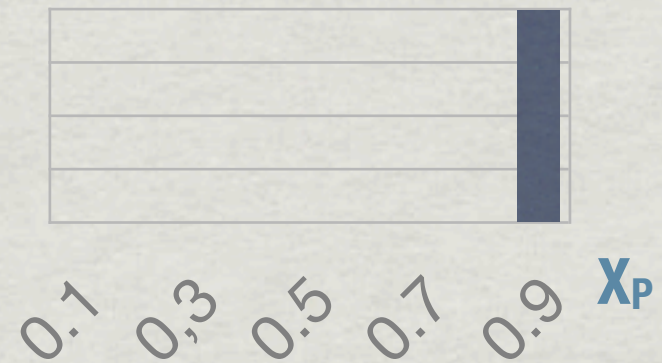

Q INCREASING

**DGLAP SPLITTING
FUNCTION**

$$P_{ji}(x_p, \alpha_s) = P_{ji}^{(0)}(x_p) + \frac{\alpha_s}{2\pi} P_{ji}^{(1)}(x_p) + \dots$$

$$\alpha_s(Q) \sim \frac{2\pi}{7 \ln(Q/\Lambda)}$$

SCALING VIOLATIONS, A PREDICTION OF QCD, SENSITIVE TO α_s

PETRA / SLC / LEP

Scaling Violations

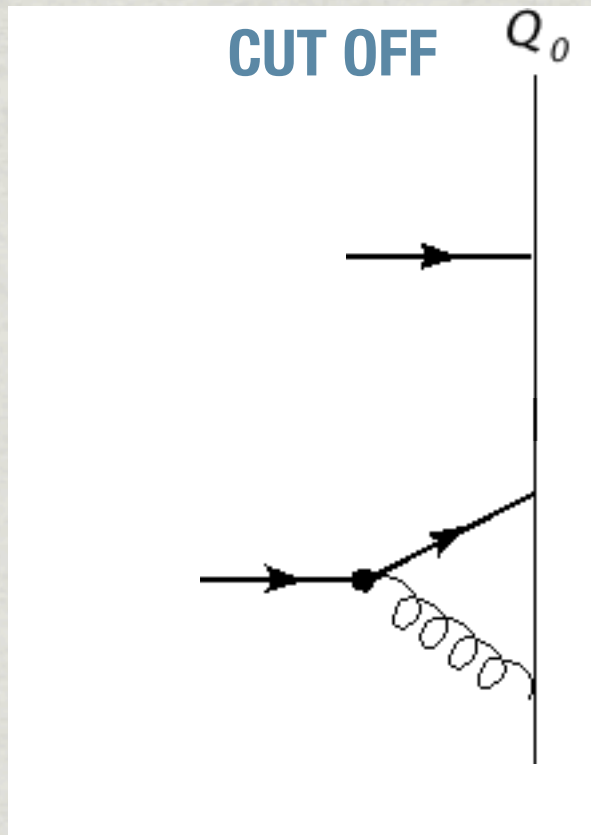

$Q \sim Q_0$, NO ROOM FOR
GLUON EMISSION

$Q > Q_0$, PROBABILITY
OF GLUON EMISSION
(E.G. 50%, 1/2 P)

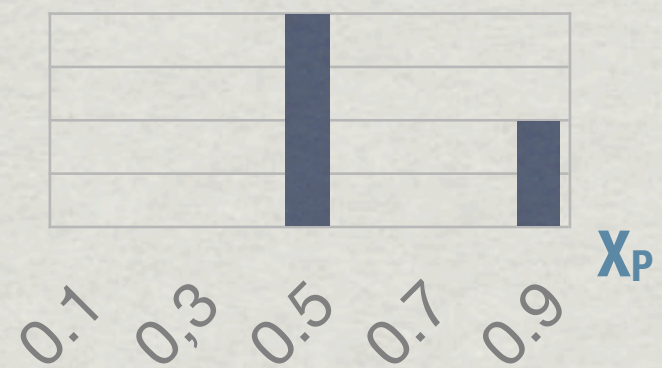
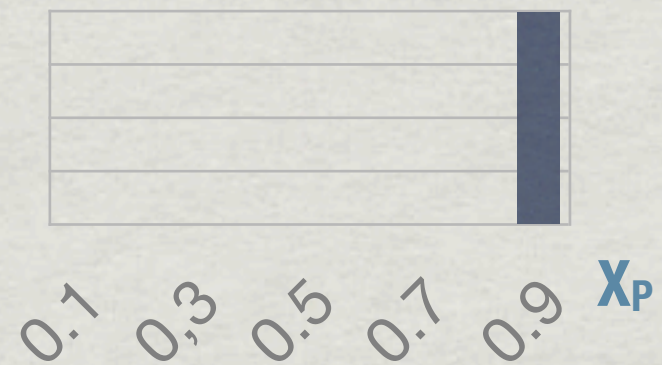

↓
Q INCREASING

**DGLAP SPLITTING
FUNCTION**

$$P_{ji}(x_p, \alpha_s) = P_{ji}^{(0)}(x_p) + \frac{\alpha_s}{2\pi} P_{ji}^{(1)}(x_p) + \dots$$

$$\alpha_s(Q) \sim \frac{2\pi}{7 \ln(Q/\Lambda)}$$

SCALING VIOLATIONS, A PREDICTION OF QCD, SENSITIVE TO α_s

PETRA / SLC / LEP

Scaling Violations

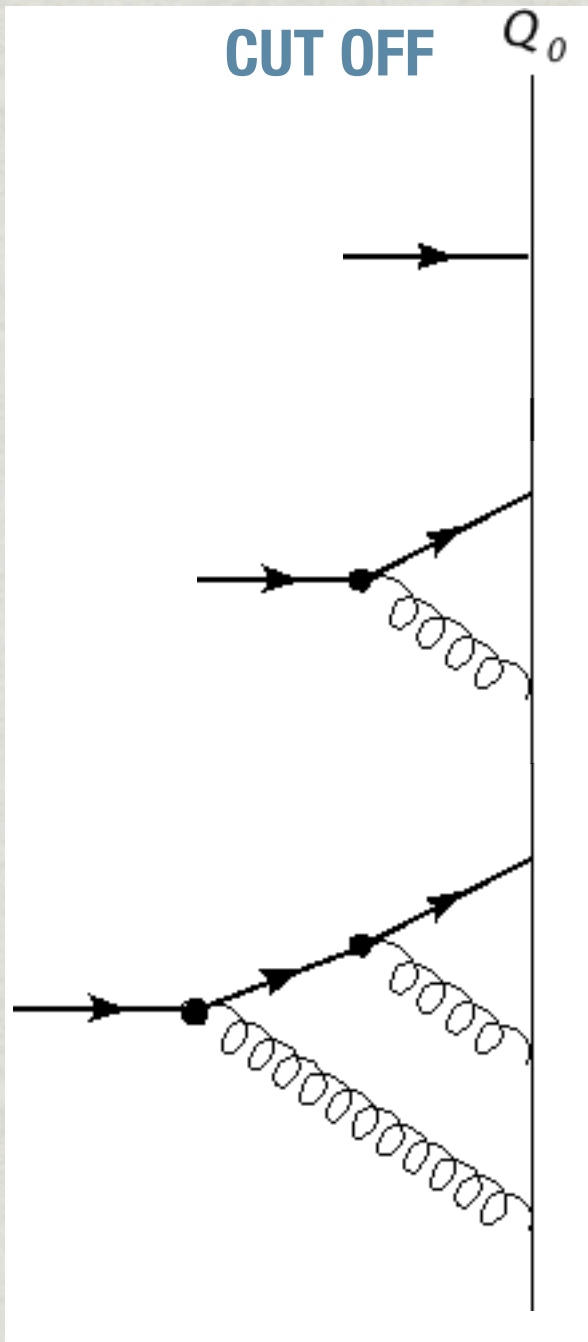

$Q \sim Q_0$, NO ROOM FOR
GLUON EMISSION

$Q > Q_0$, PROBABILITY
OF GLUON EMISSION
(E.G. 50%, 1/2 P)

$Q \gg Q_0$, ROOM FOR
MORE EMISSIONS

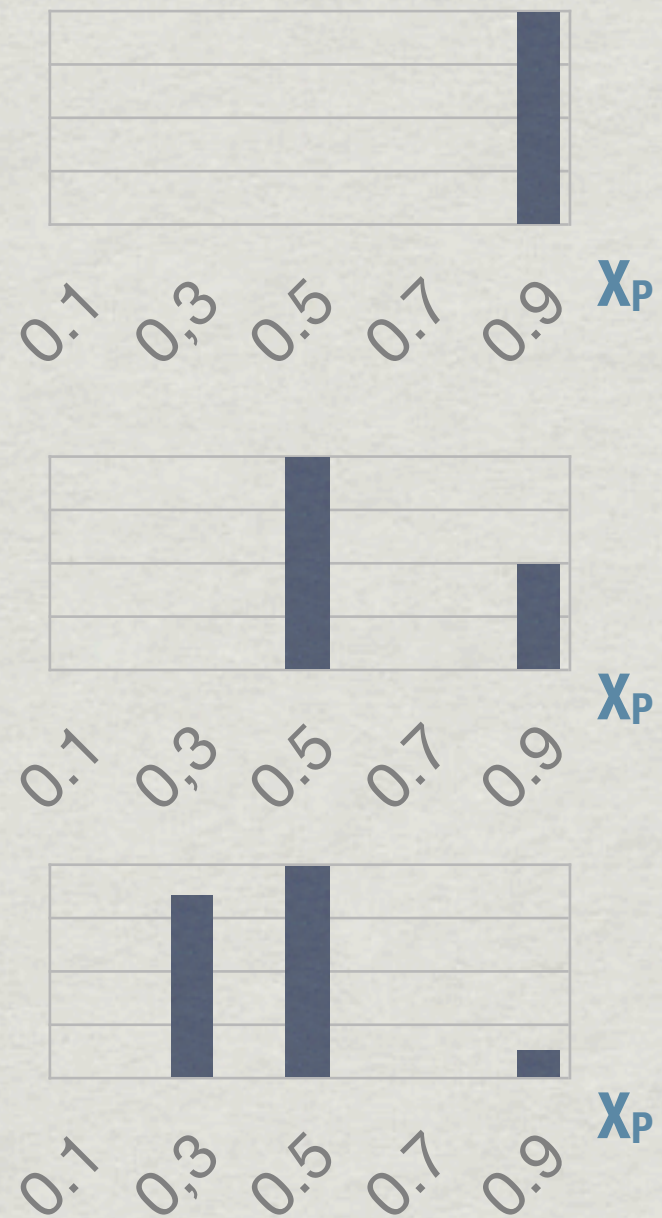

**DGLAP SPLITTING
FUNCTION**

$$P_{ji}(x_p, \alpha_s) = P_{ji}^{(0)}(x_p) + \frac{\alpha_s}{2\pi} P_{ji}^{(1)}(x_p) + \dots$$

$$\alpha_s(Q) \sim \frac{2\pi}{7 \ln(Q/\Lambda)}$$

SCALING VIOLATIONS, A PREDICTION OF QCD, SENSITIVE TO α_s

PETRA / SLC / LEP

LOG DEPENDENCE ON Q

The Breit Frame

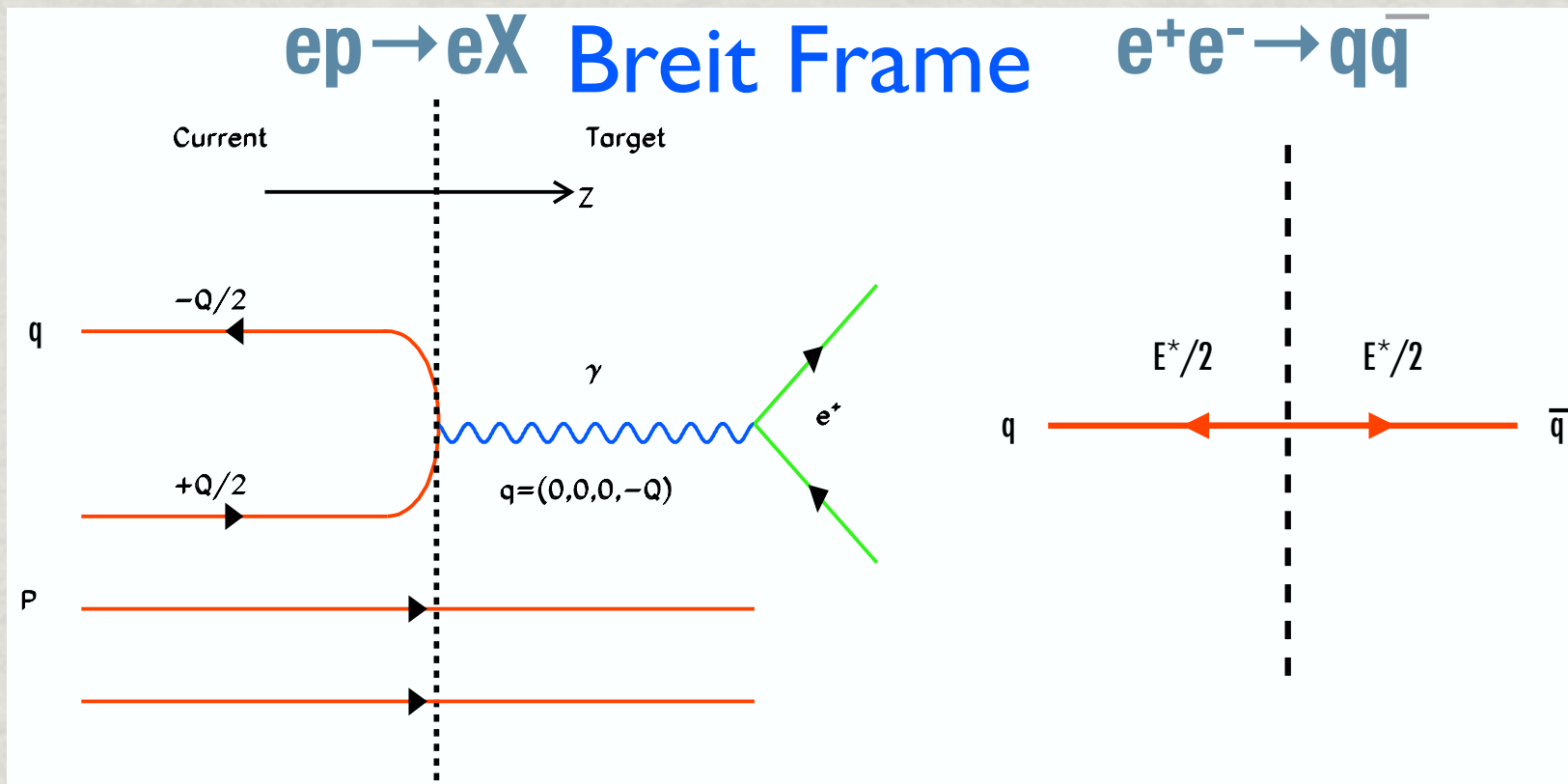

PROVIDES CLEAREST SEPARATION BETWEEN PARTICLES FROM HARD SCATTERING AND PROTON REMNANT. ALLOWS FOR EASY COMPARISON WITH e^+e^- DATA

CURRENT REGION ENERGY SCALE IS $Q/2$

BOOST TO BREIT FRAME MEANS WE MEASURE DOWN TO MOMENTUM $=0!$

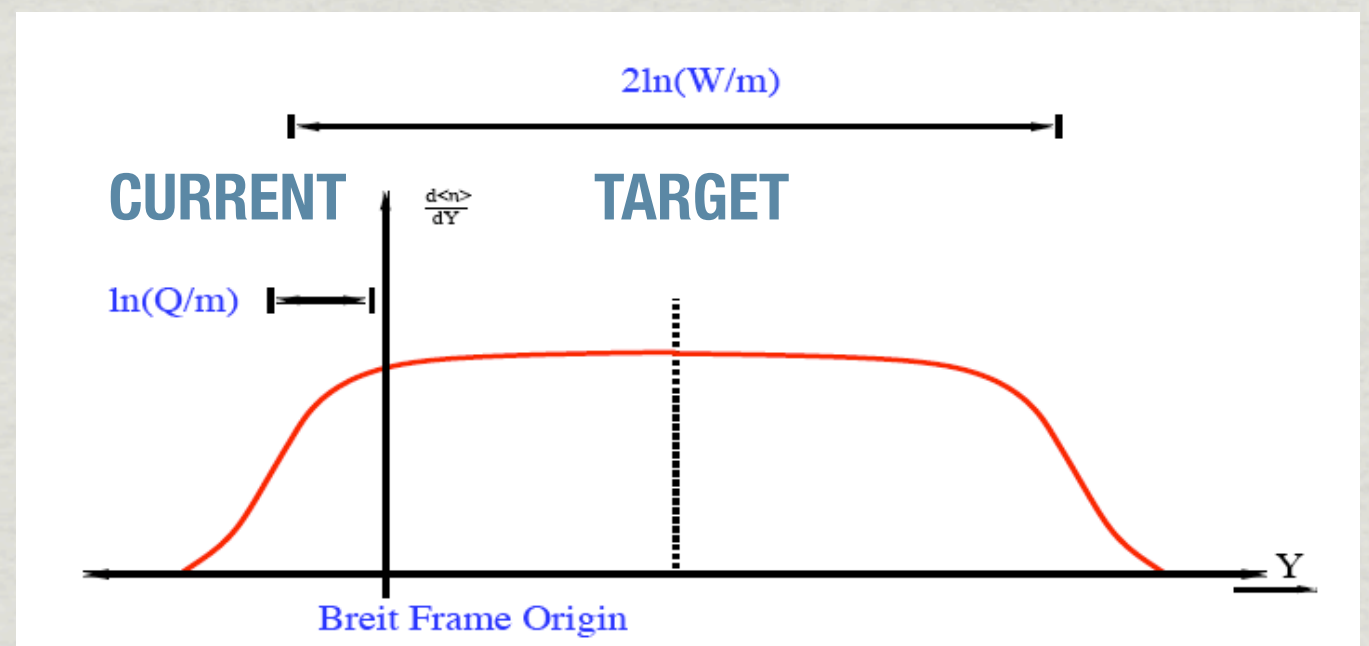

Analysis basics

KINEMATIC PHASE SPACE

$$100 < Q^2 < 20,000 \text{ GeV}^2$$

$$0.05 < y < 0.6$$

$$\theta_{\text{ELECTRON}} > 150^\circ$$

$$30^\circ < \theta_{\text{Q,LAB}} < 150^\circ$$

**QUARK SCATTERING ANGLE,
 $\theta_{\text{Q,LAB}}$, CALCULATED FROM
KINEMATICS.**

**ENSURES CURRENT REGION OF
BREIT FRAME REMAINS WITHIN
TRACKING ACCEPTANCE.
EASY TO CALCULATE IN THEORY!**

**CORRECTION FACTOR < 1.2.
DOMINATED BY BOOST TO
BREIT FRAME. CORRECTION
FOR TRACKING EFFICIENCIES
VERY SMALL**

SYSTEMATIC ERROR ~5%

**K^0 , Λ , ETC.. CONSIDERED AS
STABLE**

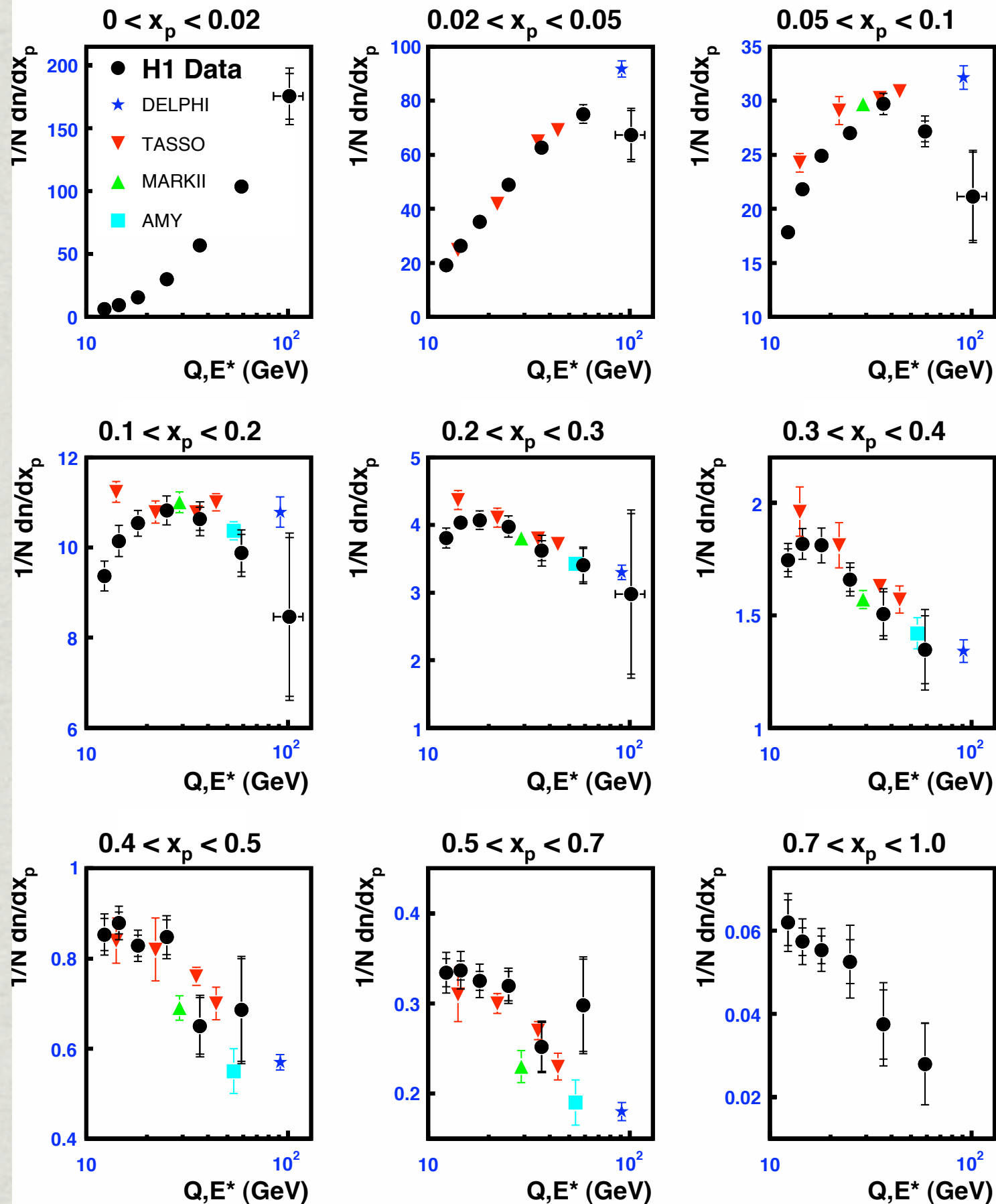

PRETTY GOOD
 AGREEMENT BETWEEN ep
 AND e⁺e⁻ !

NB: SUPPRESSED ZEROS

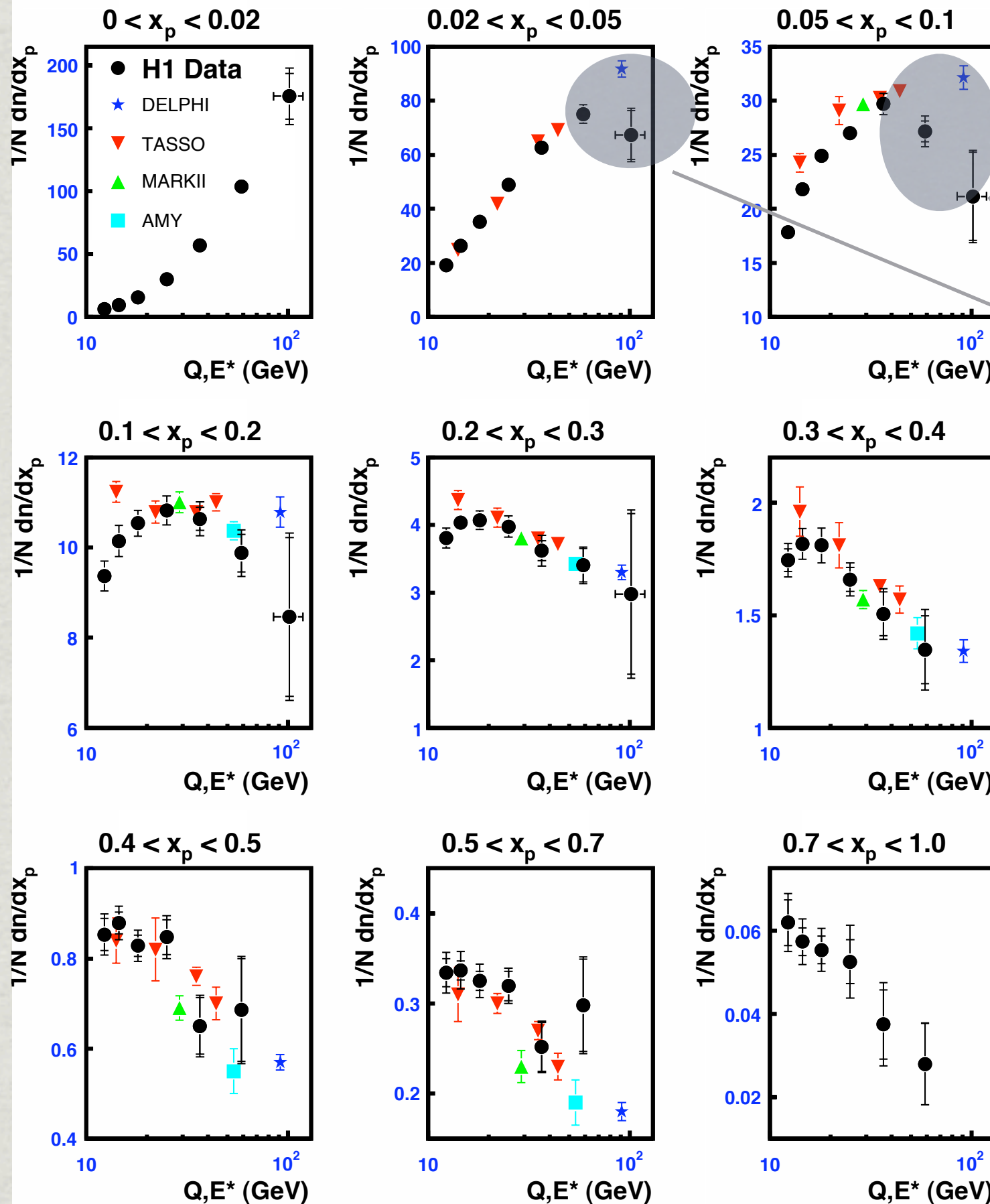

**PRETTY GOOD
AGREEMENT BETWEEN ep
AND e⁺e⁻ !**

**LARGE DIFFERENCE AT
HIGH Q AND SMALL X_P
REASON UNCLEAR**

NB: SUPPRESSED ZEROS

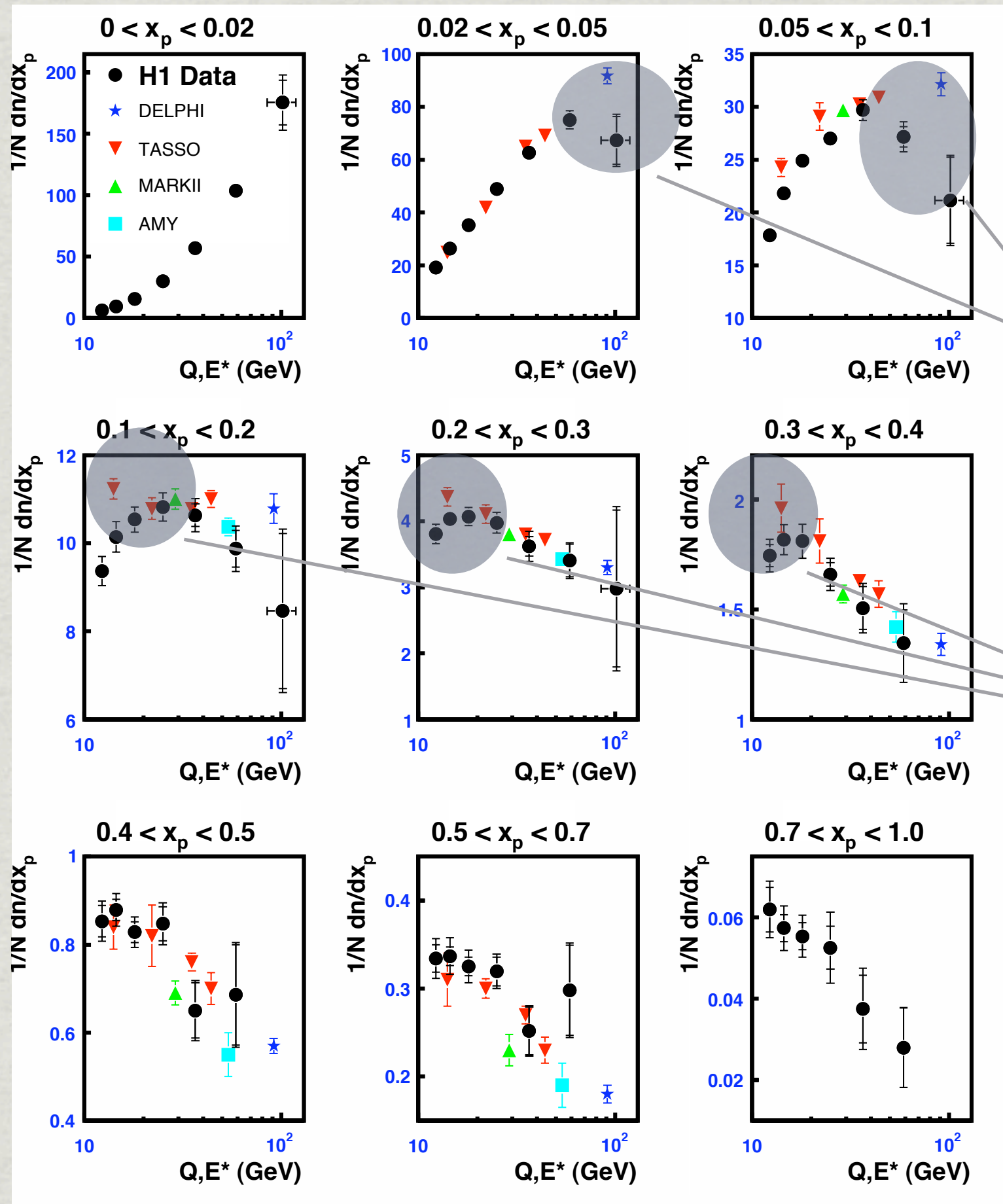

**PRETTY GOOD
AGREEMENT BETWEEN ep
AND e⁺e⁻ !**

**LARGE DIFFERENCE AT
HIGH Q AND SMALL X_P
REASON UNCLEAR**

**LOW Q, MID X_P.
EXPECTED TO BE DUE TO
BGF KINEMATICS
PRODUCING EMPTY
CURRENT REGION**

NB: SUPPRESSED ZEROS

Monte Carlo Models

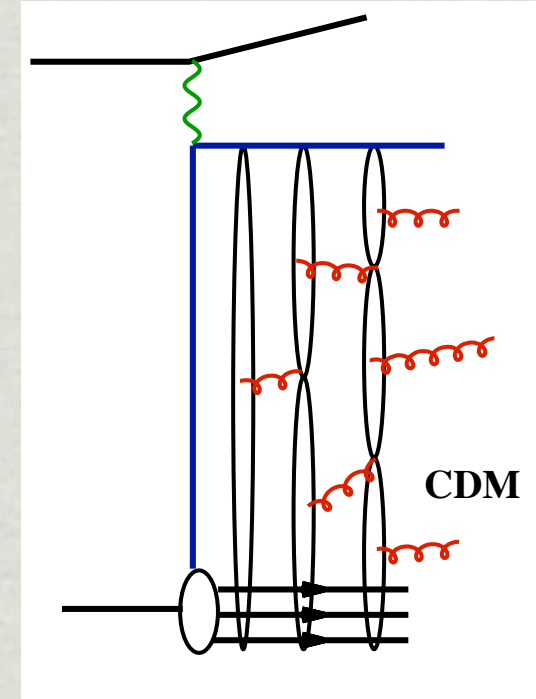
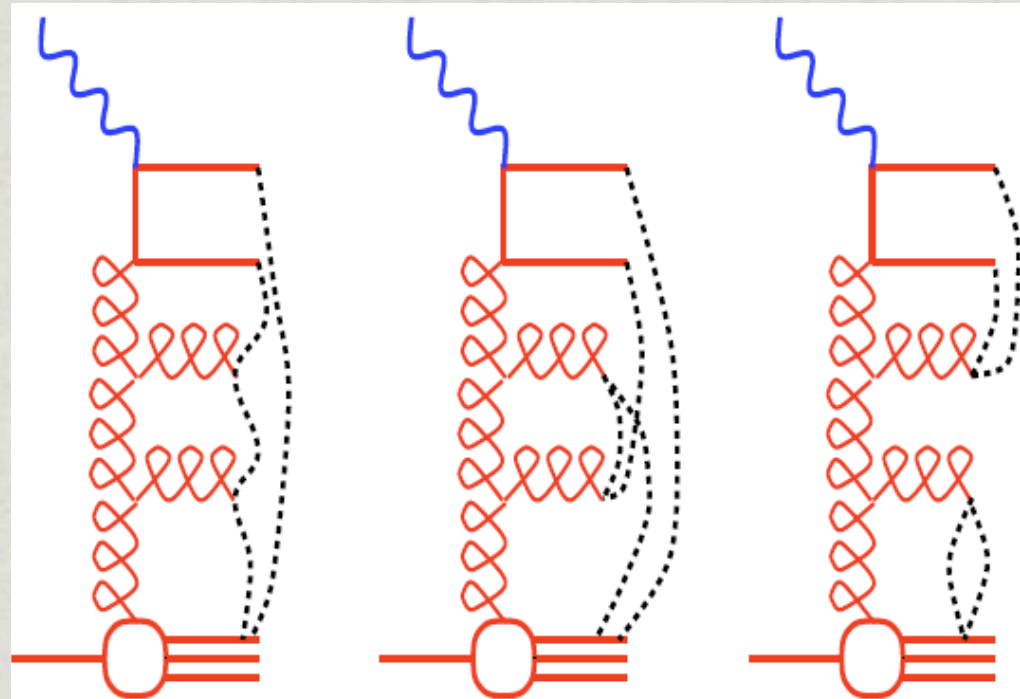
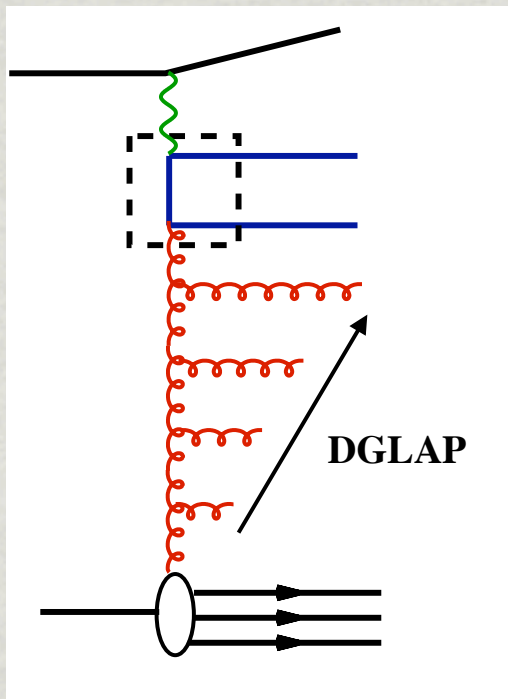

LEPTO (PARTON SHOWERS + STRING)

SCI (LEPTO + SOFT COLOUR INTERACTIONS)

ARIADNE (COLOUR DIPOLE MODEL + STRING)

RESUM $\ln(Q^2)$ TERMS, ORDER PARTON EMISSION STRONGLY WITH K_T .

RESUM $\ln(1/X)$ TERMS, WEAK K_T ORDERING.

DGLAP "LIKE"

BFKL "LIKE"

$$\sim \sum_{mn} A_{mn} \ln(Q^2)^m \ln(1/x)^n$$

Hadronisation

LUND STRING HADRONSATION

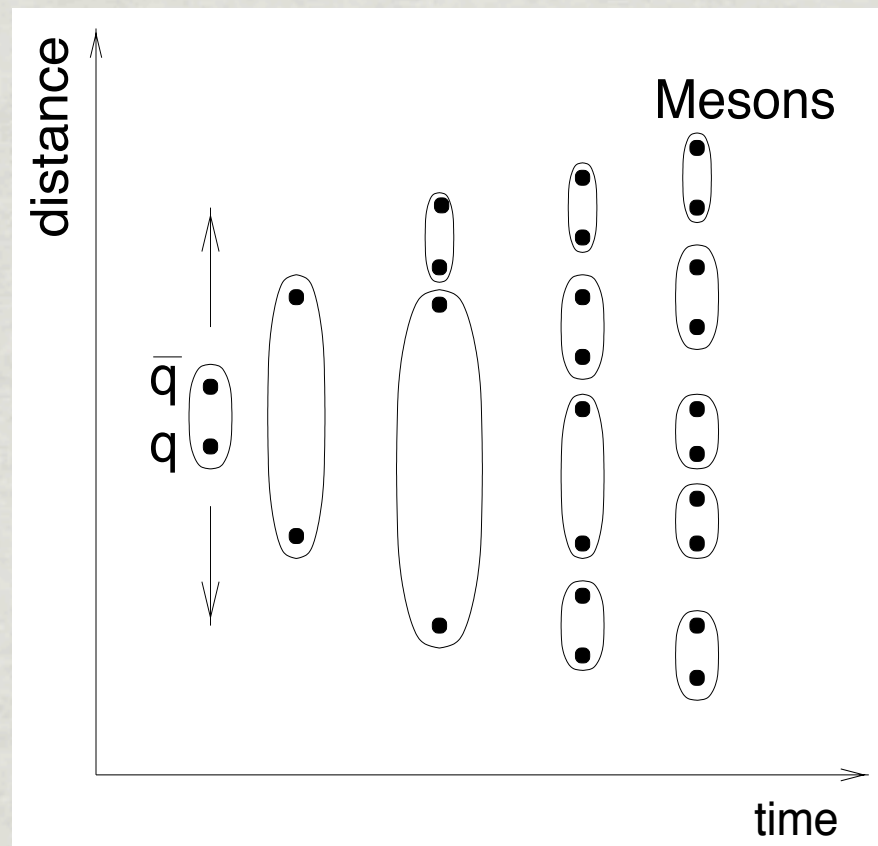

CLUSTER HADRONSATION (HERWIG)

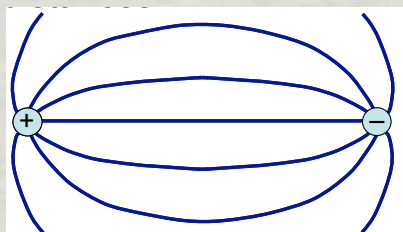
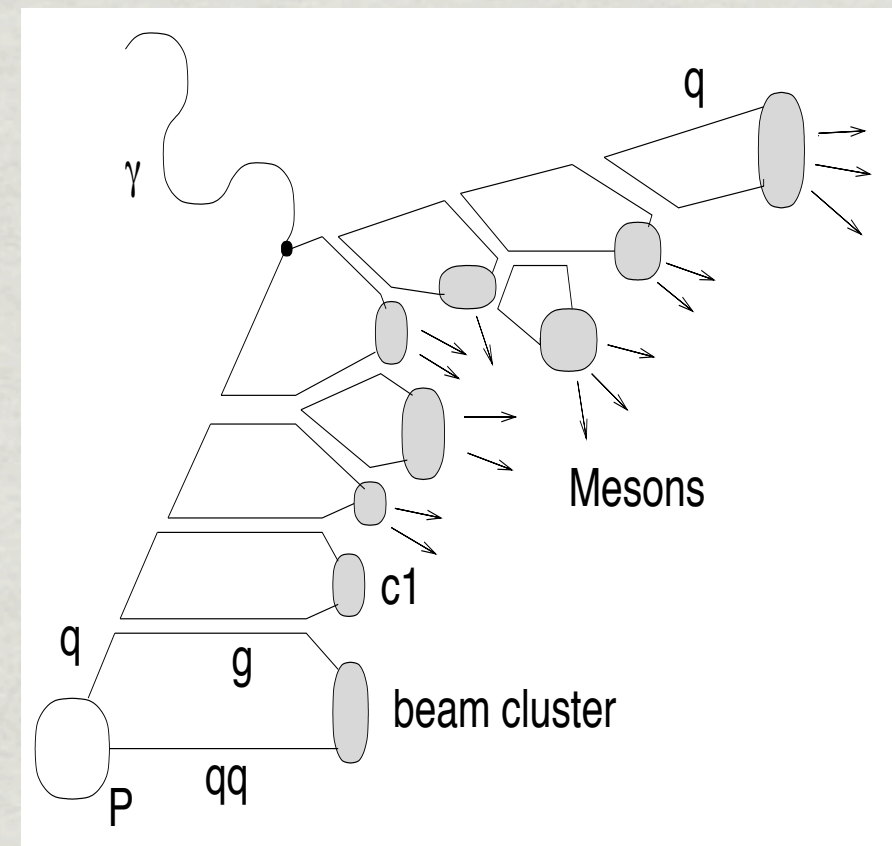

QED



QCD

LINEAR INTERQUARK POTENTIAL

THE PARTON SHOWER NATURALLY PRECONFINES COLOURED OBJECTS TOGETHER (CLUSTERS) WHICH CAN BE COMBINED INTO COLOURLESS MESONS

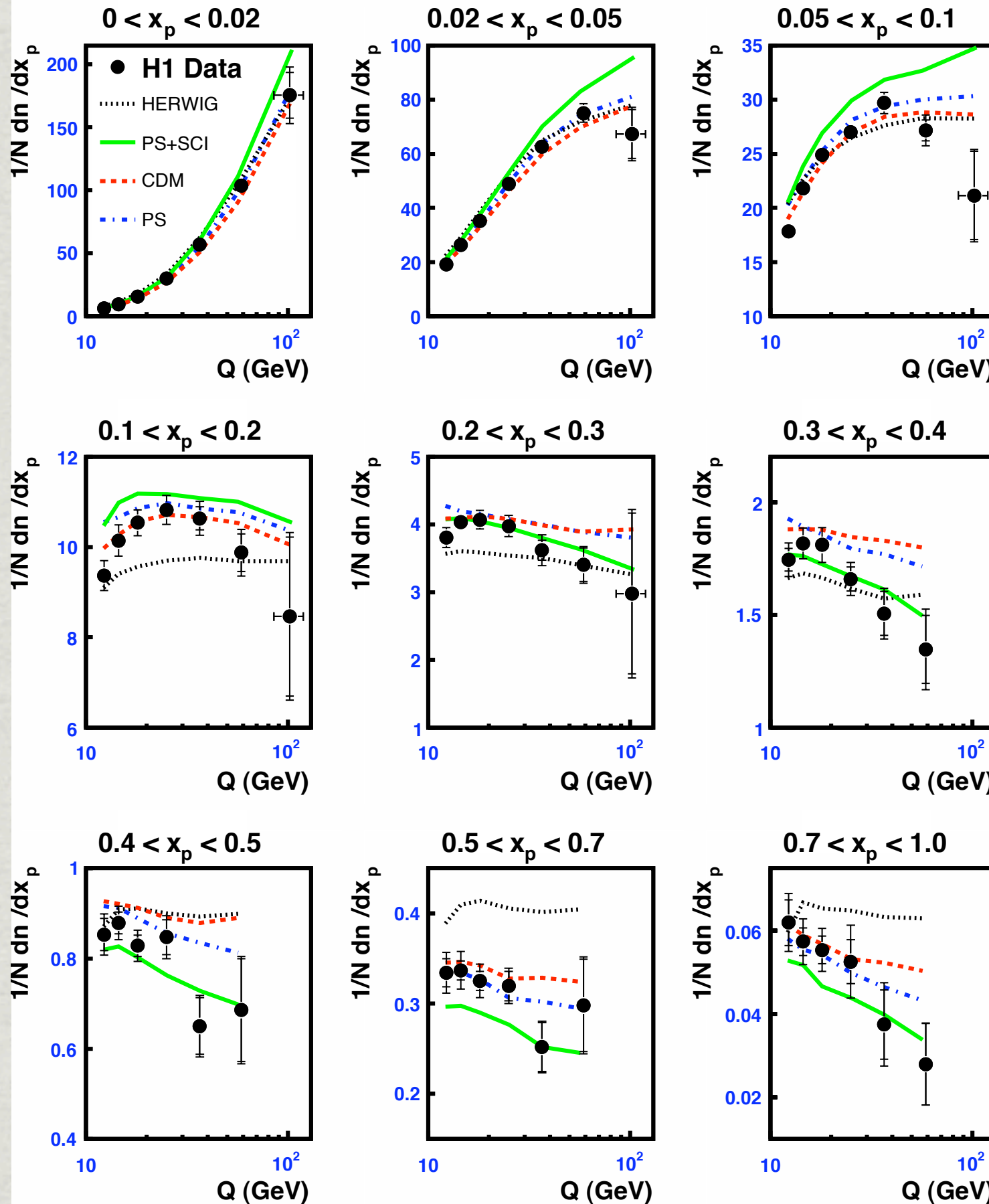

CDM AND PS
ACCEPTABLE
DESCRIPTION OF DATA.
BOTH TEND TO
OVERESTIMATE THE
MULTIPLICITY AT HIGH Q

SCI MODEL PREDICTS TOO
SOFT A SPECTRUM

HERWIG IS TOO HARD
AND FAILS TO
REPRODUCE SCALING
VIOLATIONS SEEN IN
THE DATA

Fragmentation Functions

NLO pQCD calculation
Cyclops, (D. Graudenz)

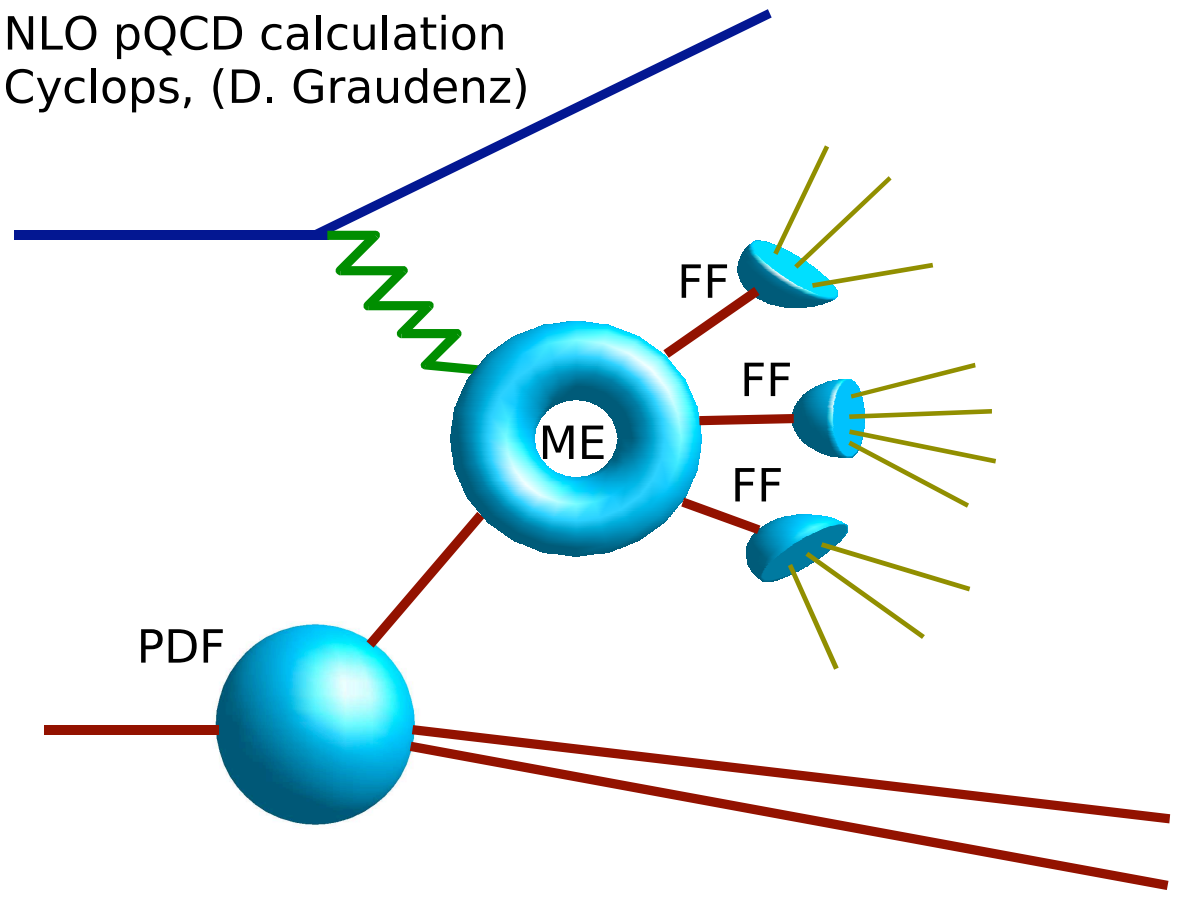

$$\sigma_h = \text{PDF} \otimes \text{M.E.} \otimes \text{FF}$$

$D^h_i(X_P, Q)$ GIVES THE DISTRIBUTION OF MOMENTUM FRACTION X_P FOR HADRONS OF TYPE h IN A JET INITIATED BY A PARTON OF TYPE i PRODUCED IN A HARD PROCESS AT SCALE Q

NLO PQCD CYCLOPS

FRAGMENTATION FUNCTIONS - $e+e-$ FITS

INFRA RED SAFE REGION
($Q^2 > 100$), $X_P > 0.1$

FF PARAMETERISED FROM $X_P > 0.1$

HIGHEST Q^2 BIN (8,000 - 20,000) LOW IN STATISTICS.

CTEQ6M, $\Lambda(5)_{\text{QCD}} = 226 \text{ MEV}$ (ALSO ME + FF) $\sim \alpha_s$

Comparison to NLO

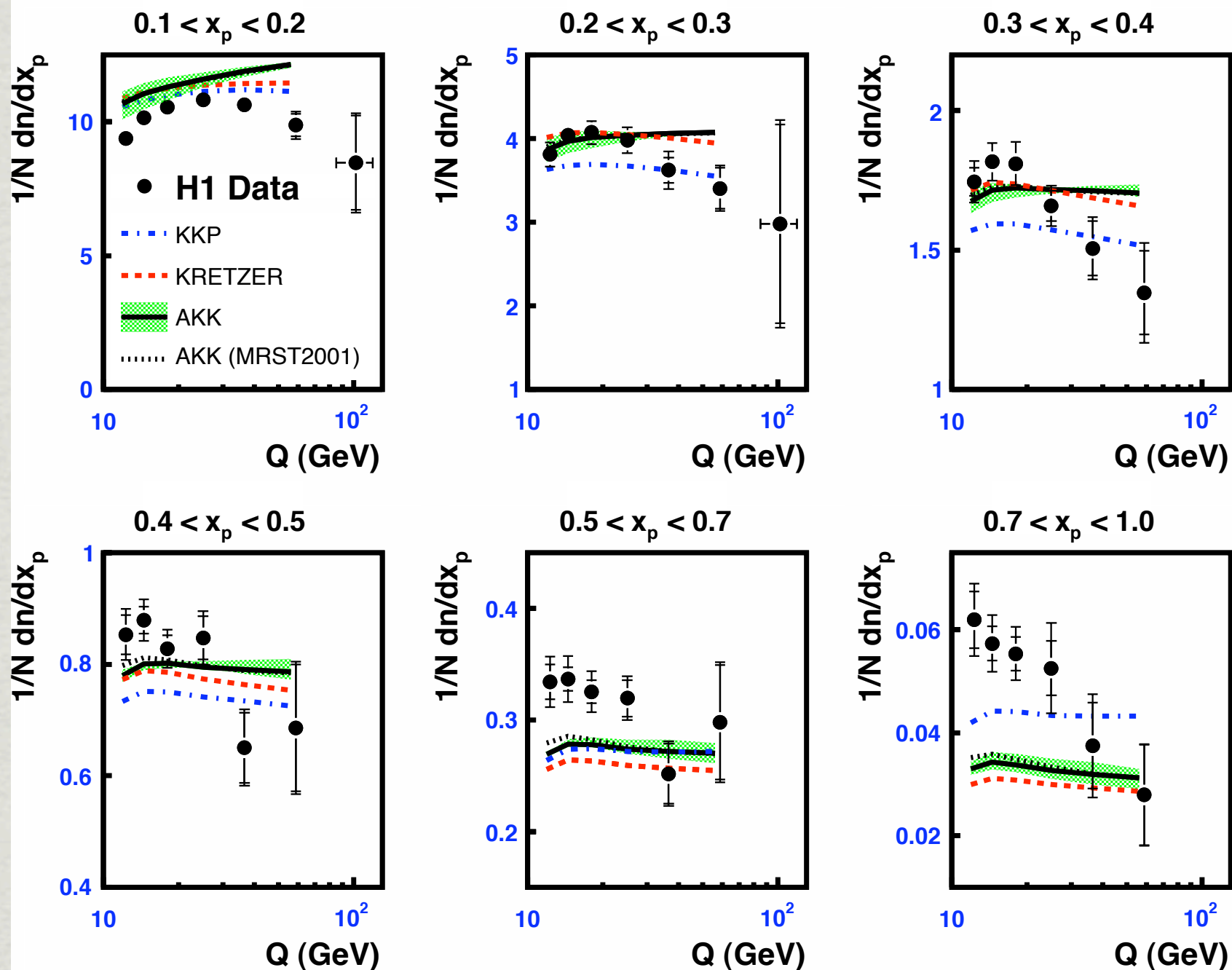

**FRAGMENTATION
FUNCTIONS (KKP,
KRETZER,
AKK) TAKEN FROM
FITS TO E+E- DATA**

**SCALE AND PDF
ERRORS SMALL**

**SENSITIVITY TO
DIFFERENT FF**

NLO THEORY DOES NOT DESCRIBE THE DATA!

Strangeness in DIS

Analysis basics

KINEMATIC PHASE SPACE

$$2 < Q^2 < 100 \text{ GeV}^2$$

$$0.05 < y < 0.6$$

$$0.5 < P_{T,K^0,\Lambda} < 3.5 \text{ GeV}$$

$$|\eta_{K^0,\Lambda}| < 1.3$$

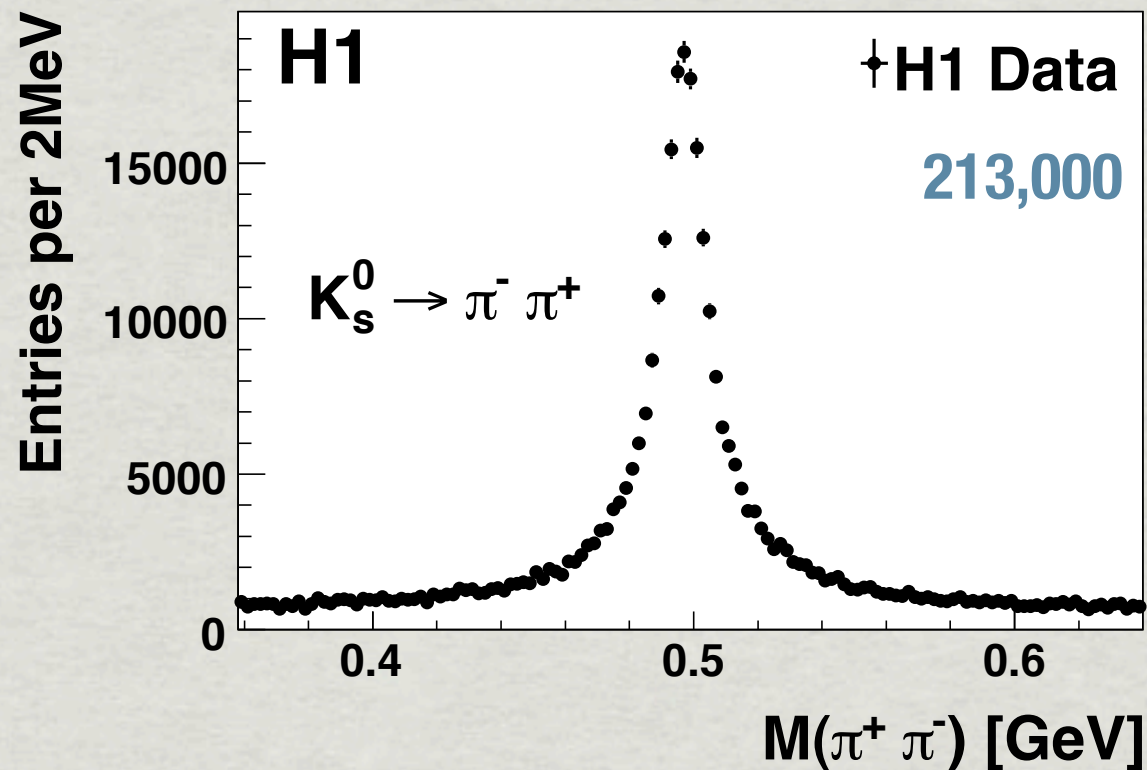

DOUBLE GAUSSIAN + LINEAR BACKGROUND

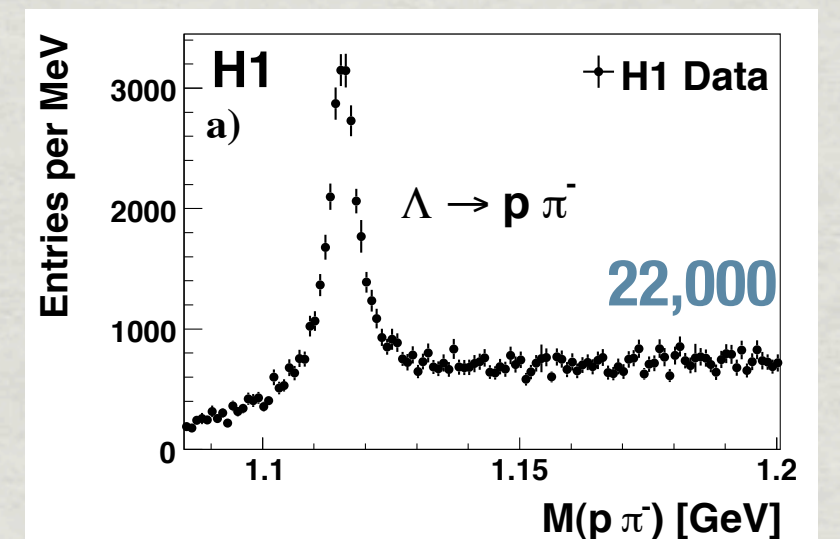
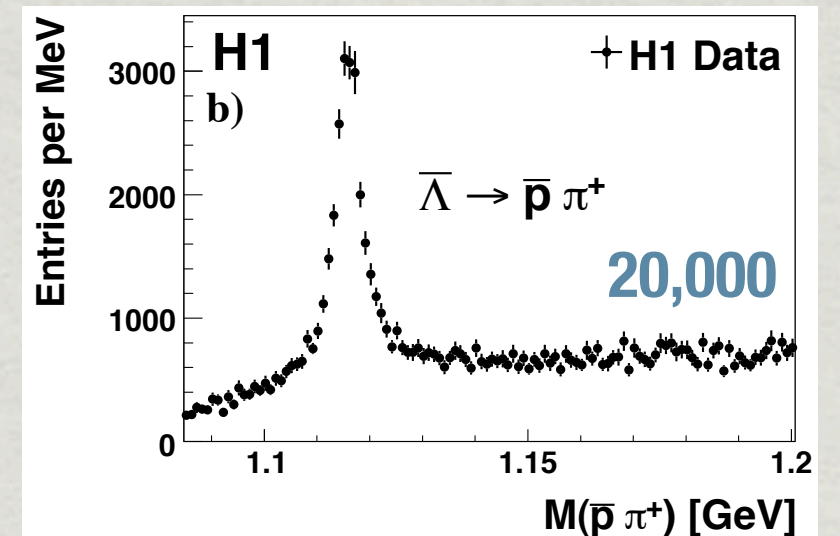

DOUBLE GAUSSIAN + BACKGROUND

Strangeness K^0

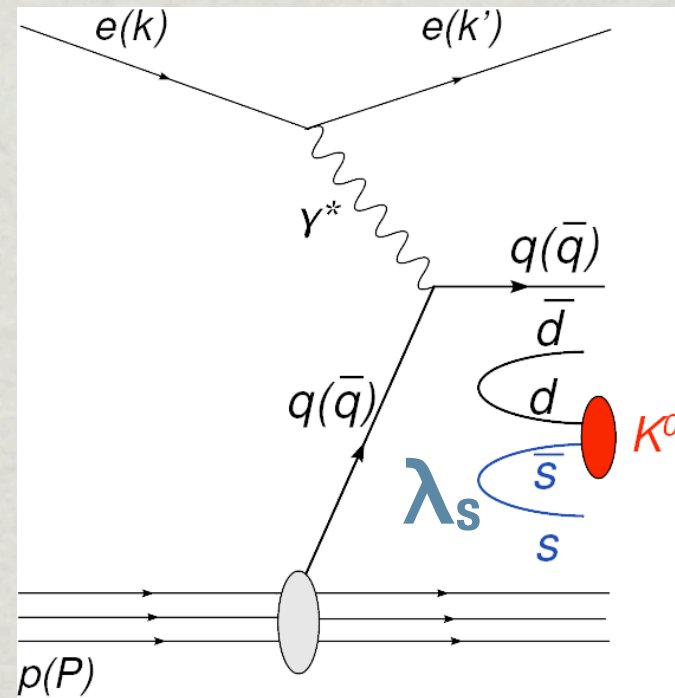
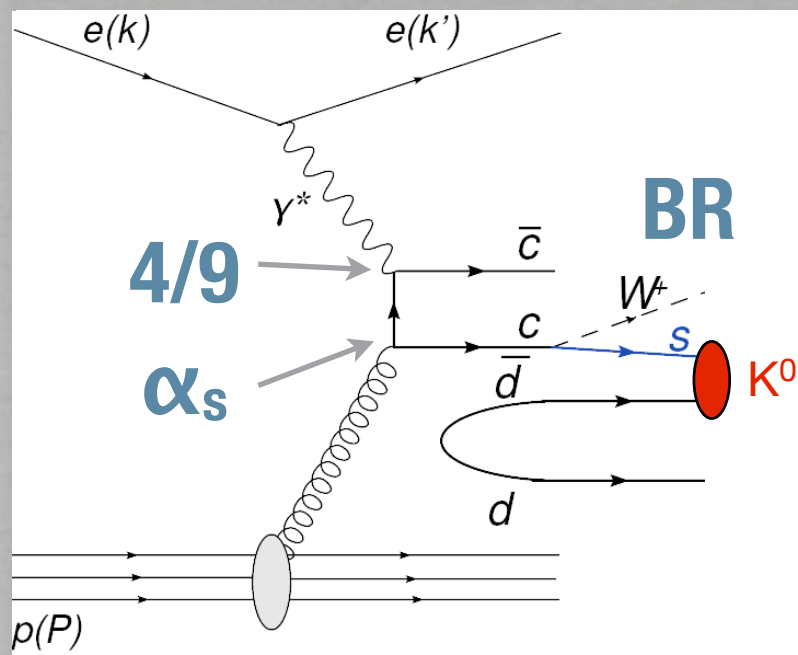
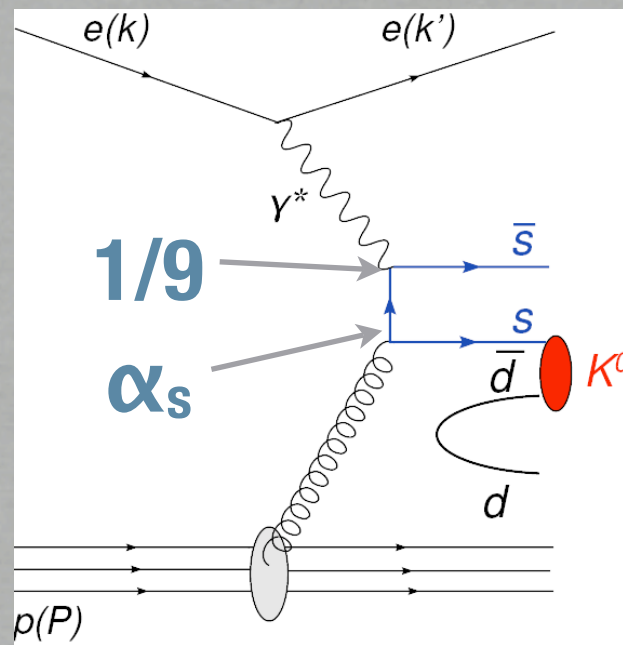
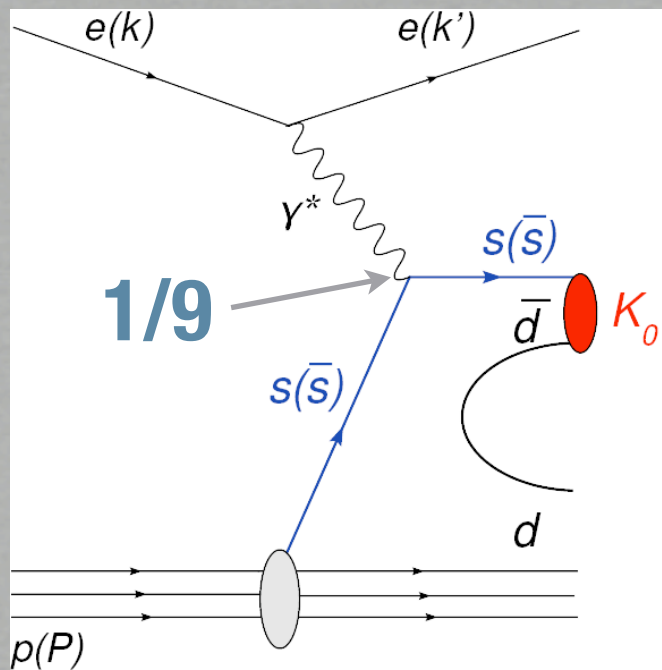

SUPPRESSION

$$q = 1/3, \alpha_s$$

BRANCHING FRACTIONS
FRAGMENTATION λ_s

25% FROM THE HARD
INTERACTION

STRANGENESS SUPPRESSION
FACTOR, λ_s , THE PROBABILITY
OF CREATING A STRANGE QUARK
COMPARED TO u OR d IN THE
NON-PERTURBATIVE PROCESS

EXPECT λ_s TO BE UNIVERSAL;
ALEPH TUNE, $\lambda_s = 0.286$,

Strangeness K^0

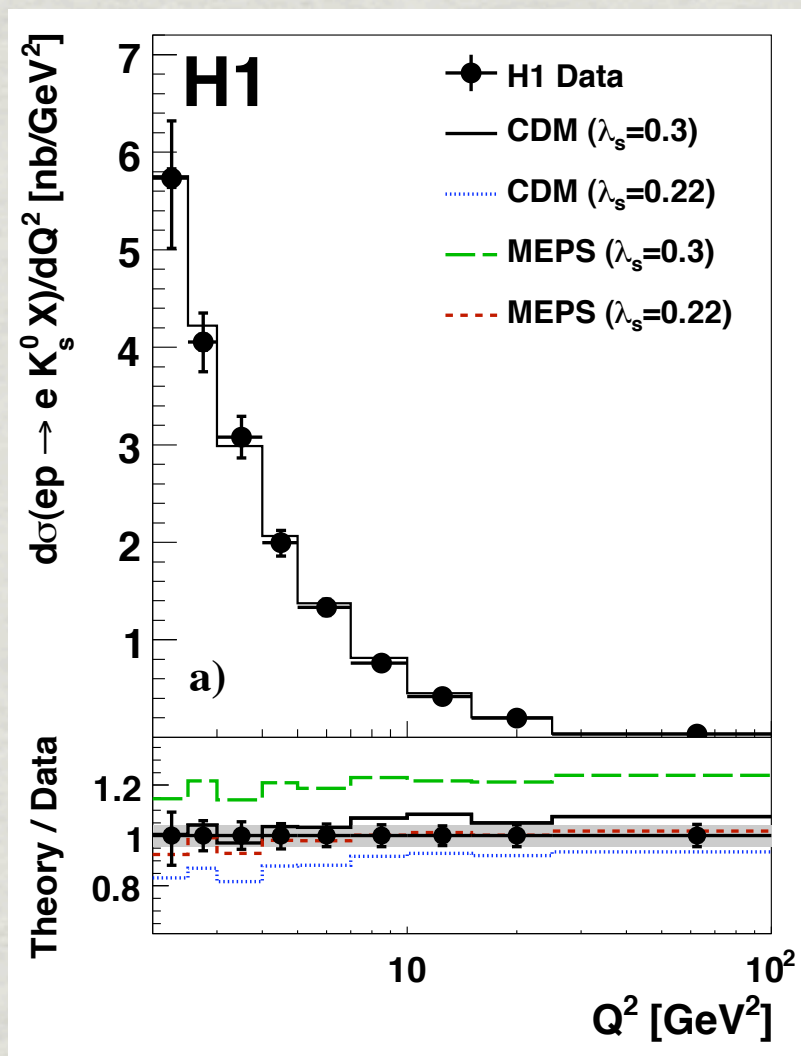

PS - $\lambda_s \sim 0.22$

CDM - $\lambda_s \sim 0.3$

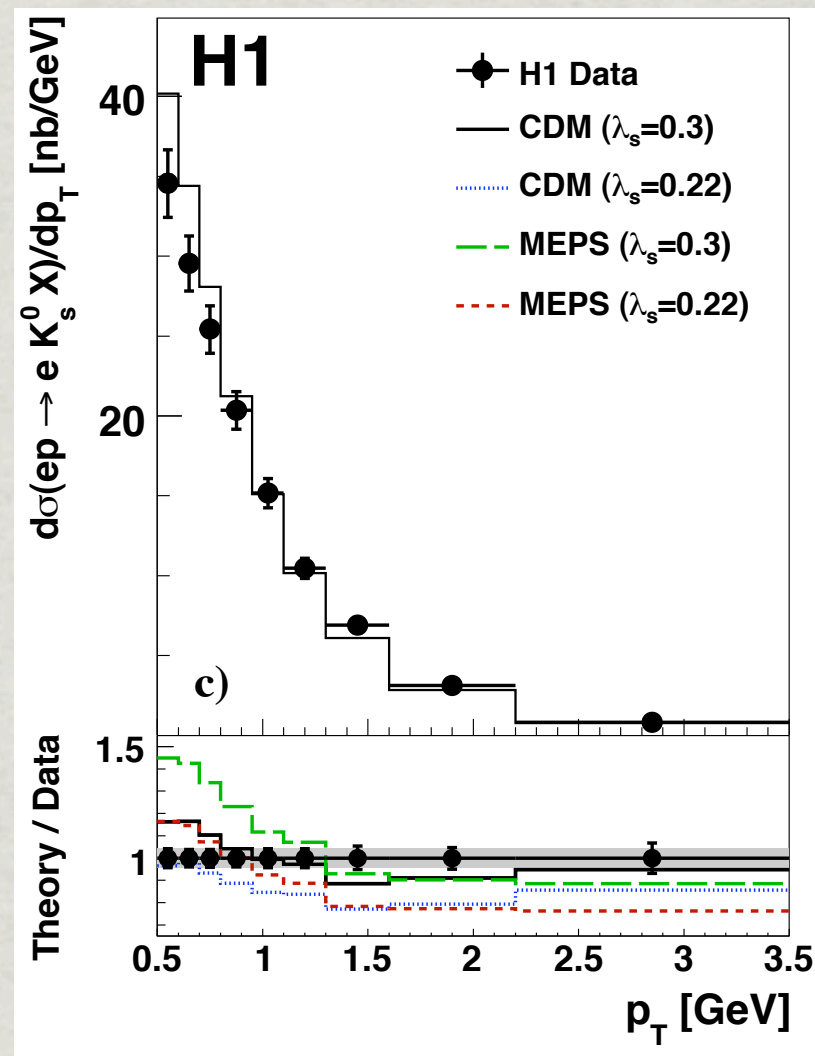

p_T SHAPE WRONG FOR ALL

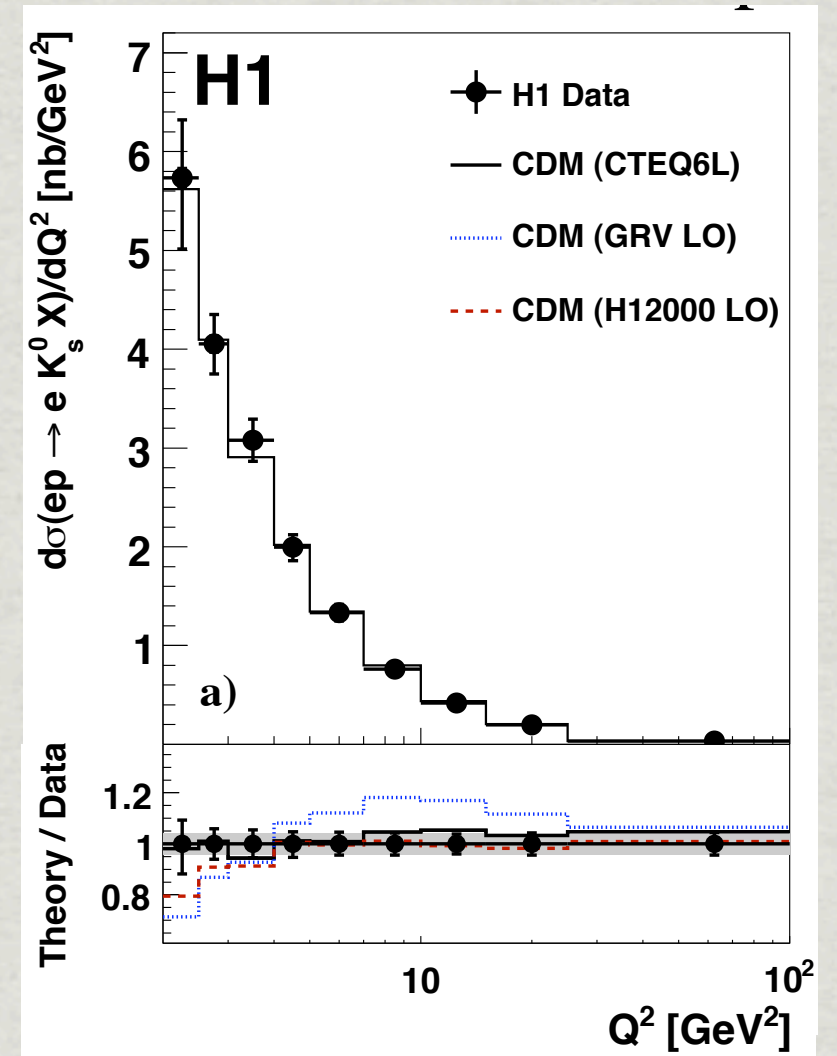

SOME PDF DEPENDENCE

SIMILAR STORY FOR OTHER VARIABLES;
 η , X_{BJ} , BERIT FRAME, ETC...

NO ONE MODEL OR λ_s CAN DESCRIBE ALL DATA

CDM - $\lambda_s \sim 0.3$ PREFERRED

Strangeness K^0

ep PHYSICS MORE
COMPLICATED THAN e^+e^- , MAY
CAUSE SOME OF THE
DIFFERENCE

TAKE RATIO OF K^0 TO ALL
CHARGED PARTICLES ($\sim\pi$)

ONLY THE DIFFERENCES IN
PARTICLE PRODUCTION
BETWEEN ud AND s LEFT

BOTH PS AND CDM
SIMILAR PREDICTIONS FOR
SIMILAR λ_s

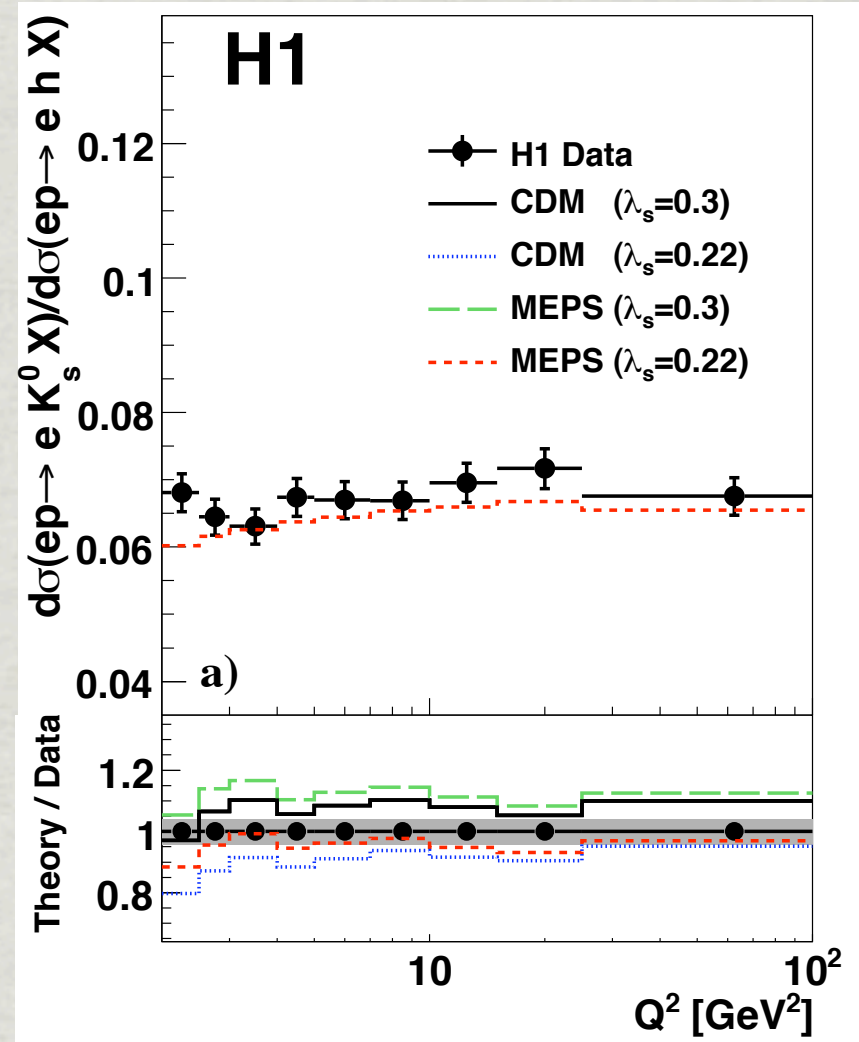

CONSTANT FOR η , Q , X_{BJ}

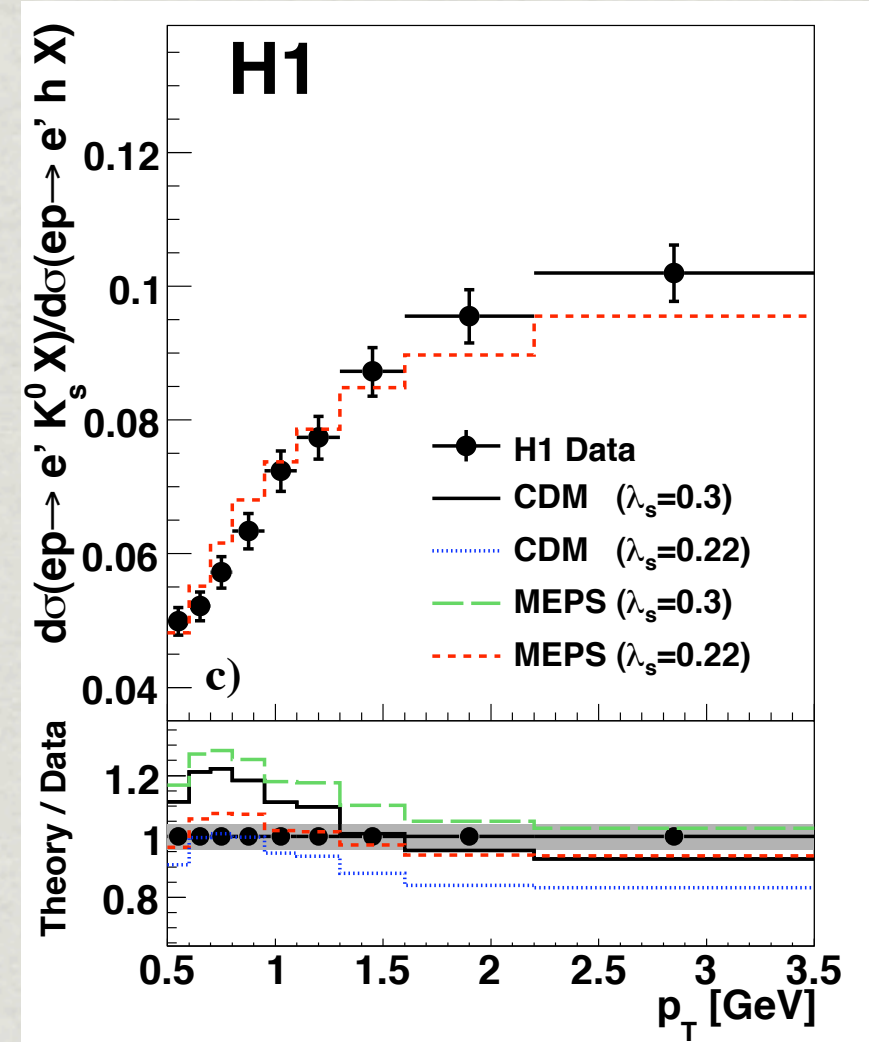

STRONG DEPENDENCE ON
 p_T , EXPECTED

Strangeness Λ

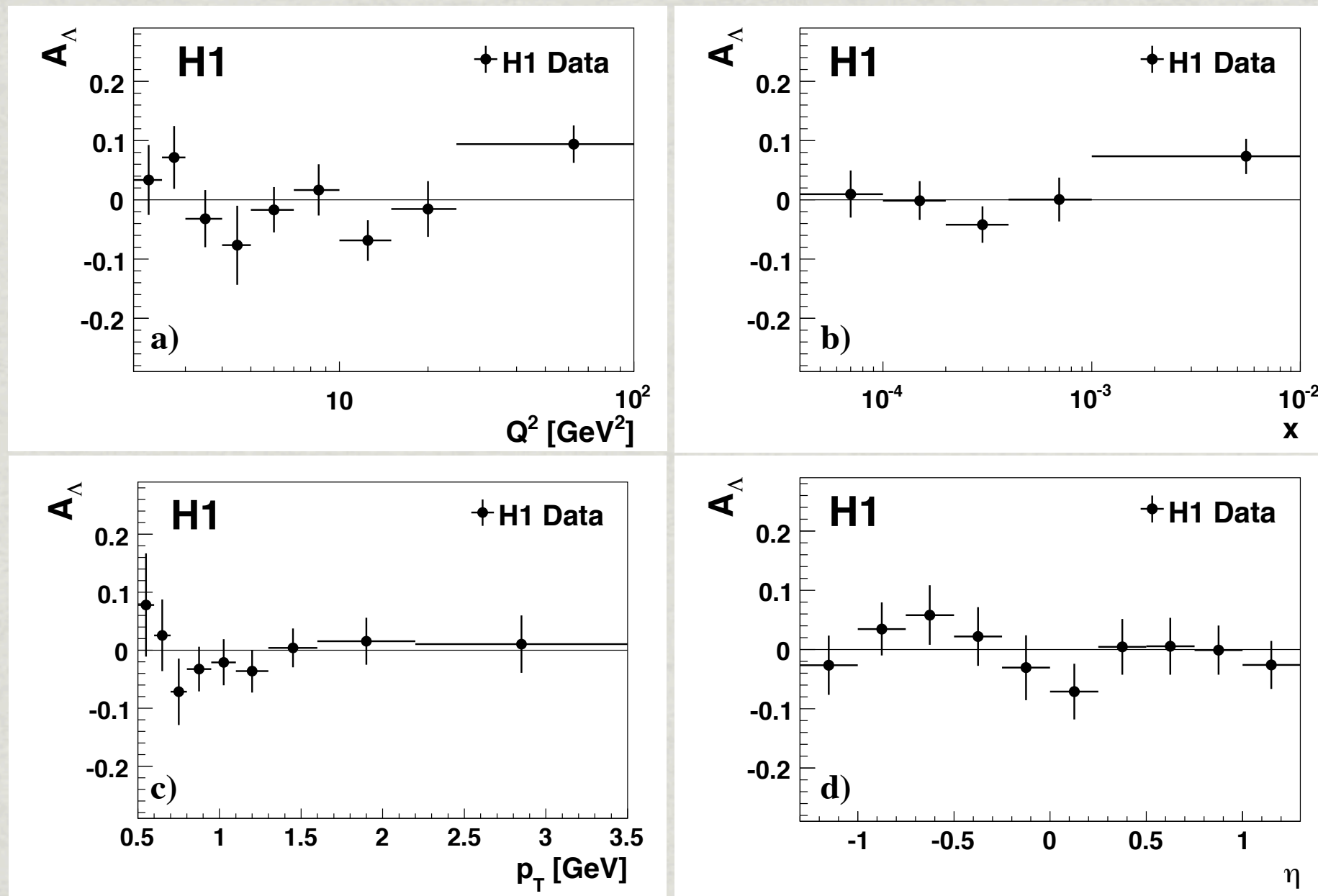

A SIGNIFICANT ASYMMETRY BETWEEN $\Lambda\Lambda$ WOULD INDICATE THAT BARYON NUMBER WAS BEING TRANSFERRED FROM THE PROTON BEAM TO THE FINAL STATE

ALL DISTRIBUTIONS CONSISTENT WITH ZERO - BUT LIMITED ACCEPTANCE

Strangeness in γp

Analysis basics

$\rho^0(770) \rightarrow \pi^+\pi^-$
 $\phi(1020) \rightarrow K^+K^-$
 $K^{*0}(892) \rightarrow K^{+/-}\pi^{-/+}$

QUASI-REAL PHOTON
 PROTON INTERACTIONS

TAGGED PHOTOPRODUCTION

$$Q^2 < 0.04 \text{ GeV}^2$$

$$174 < W < 256 \text{ GeV}$$

$$\langle W \rangle = 210 \text{ GeV}$$

$$P_{T,\rho^0 K^{*0} \phi} > 0.5 \text{ GeV}$$

$$|\eta_{\rho^0 K^{*0} \phi}| < 1.0$$

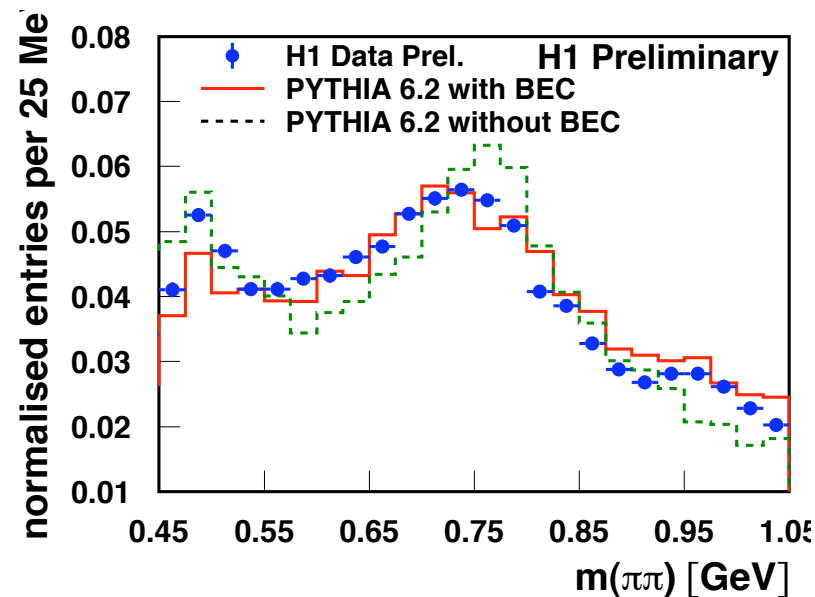

BOSE-EINSTEIN CORRELATIONS

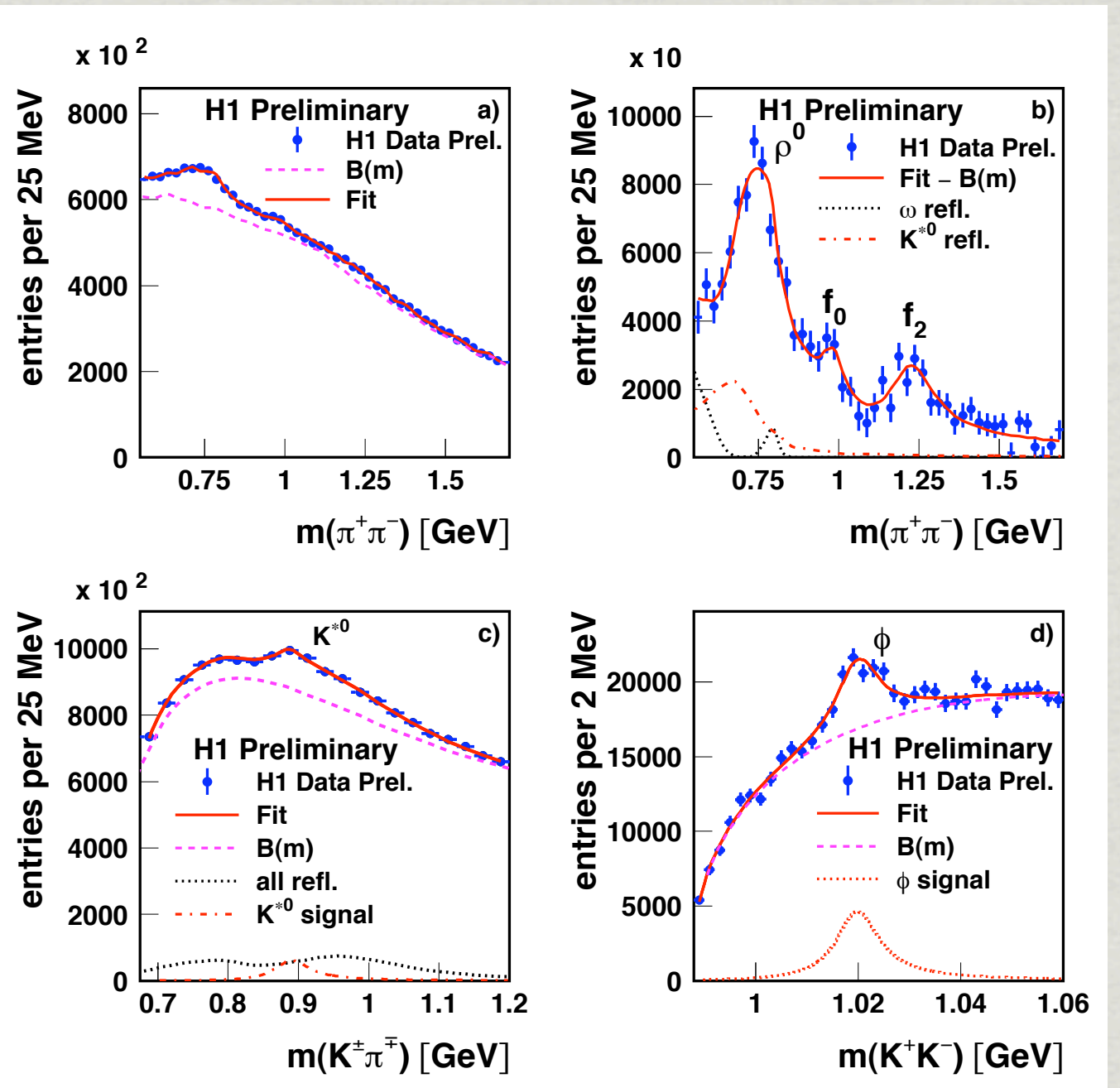

$$F(m) = B(m) + \Sigma R(m) + \Sigma S(m)$$

RELATIVISTIC BREIT-WIGNER + RESOLUTION FUNCTION

Strangeness in γp

**DAMPED POWER LAW
UBIQUITOUS IN NATURE**

$$\frac{1}{\pi} \frac{d^2 \sigma^{\gamma p}}{dp_T^2 dy} = \frac{A}{(E_{T_0} + E_T^{kin})^n}$$

**NORMALISATION
FACTOR**

$$E_T^{kin} = \sqrt{m_0^2 + p_T^2} - m_0$$

**TRANSVERSE
KINETIC ENERGY**

**CLASSICAL THERMODYNAMIC
ANALOGY, BOLTZMANN LIKE
EXPONENTIAL**

$$\exp(-E_T^{kin}/T) \quad E_T^{kin} \text{ small}$$

$$T = E_{T_0}/n$$

**TEMPERATURE AT WHICH
HADRONISATION TAKES PLACE**

$$E_T^{kin} \text{ large} \\ E_{T_0} = 0$$



**POWER LAW AS
EXPECTED FROM QCD**

**IN pQCD n IS A CONVOLUTION OF
PARTON DENSITIES AND PARTON
PARTON CROSS SECTIONS**

Strangeness in γp

$n=6.7$ TAKEN FROM PRECISE CHARGED
PARTICLE DATA

PARTICLES PRODUCED WITH DIFFERENT
MASSES, LIFETIMES AND STRANGENESS
CONTENT HAVE SAME AVERAGE
TRANSVERSE KINETIC ENERGY

THERMODYNAMIC PICTURE OF
HADRONISATION WHERE PRIMARY
PARTICLES THERMALISED DURING
HADRONISATION

$$\langle p_t \rangle = \sqrt{\langle E_T^{kin} \rangle^2 + 2 \langle E_T^{kin} \rangle m_0}$$

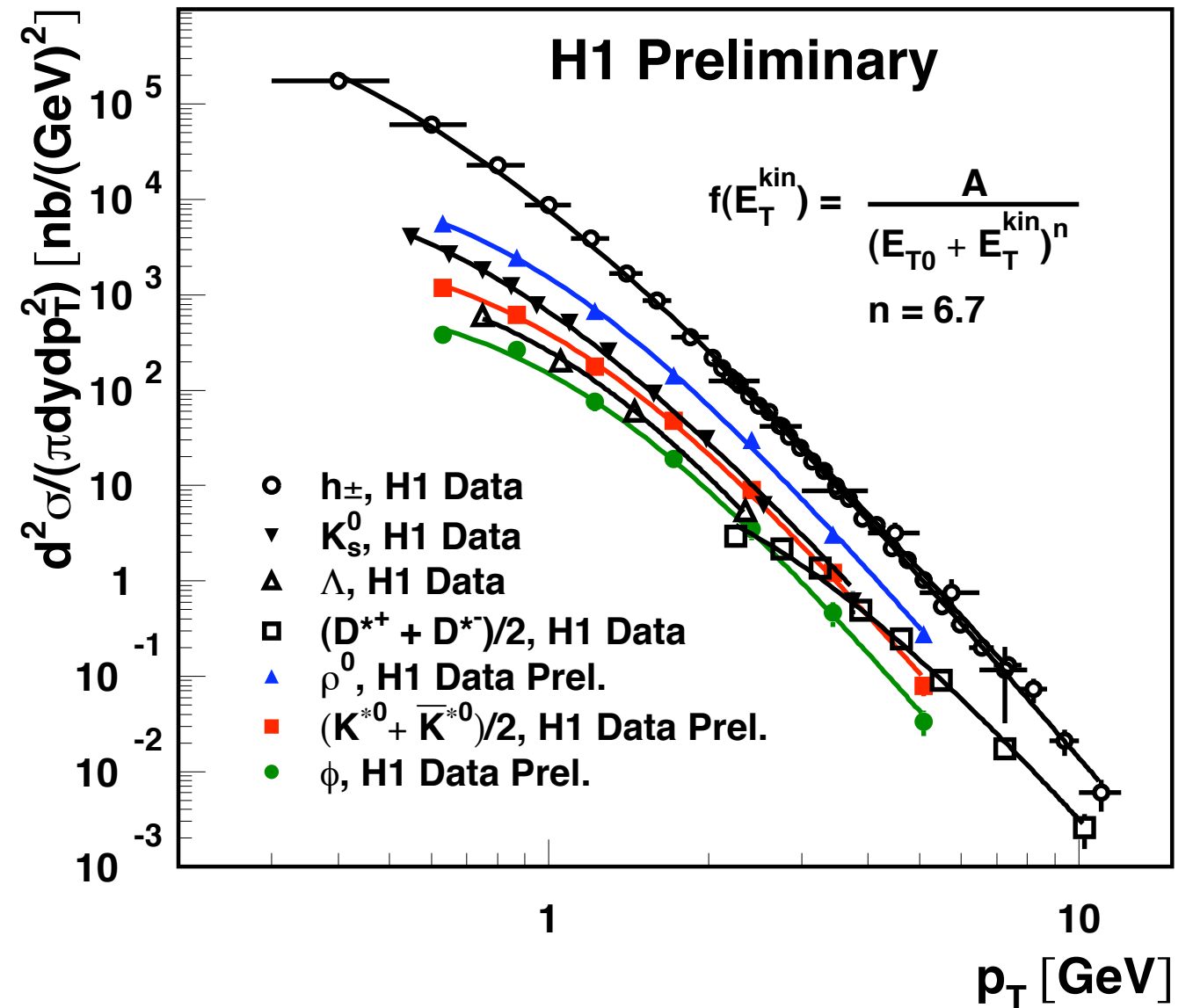

	ρ^0	K^{*0}	ϕ
$\langle p_t \rangle_{\gamma p}$	0.726 ± 0.021	0.811 ± 0.025	0.860 ± 0.032
$\langle p_t \rangle_{pp}$	0.616 ± 0.062	0.81 ± 0.14	0.82 ± 0.03
$\langle p_t \rangle_{AuAu}$	0.83 ± 0.1	1.08 ± 0.14	0.97 ± 0.02

	ρ^0	K^{*0}	ϕ
$T_{\gamma p}$	0.151 ± 0.006	0.166 ± 0.008	0.170 ± 0.009
T_{Pythia}	0.136	0.14	0.149

Strangeness in γp

CROSS SECTION RATIOS

INTEGRATED OVER p_t AND y

$$R(K^{*0}/\rho^0) = 0.221 \pm 0.033$$

$$R(\phi/\rho^0) = 0.078 \pm 0.012$$

$$R(\phi/K^{*0}) = 0.354 \pm 0.055$$

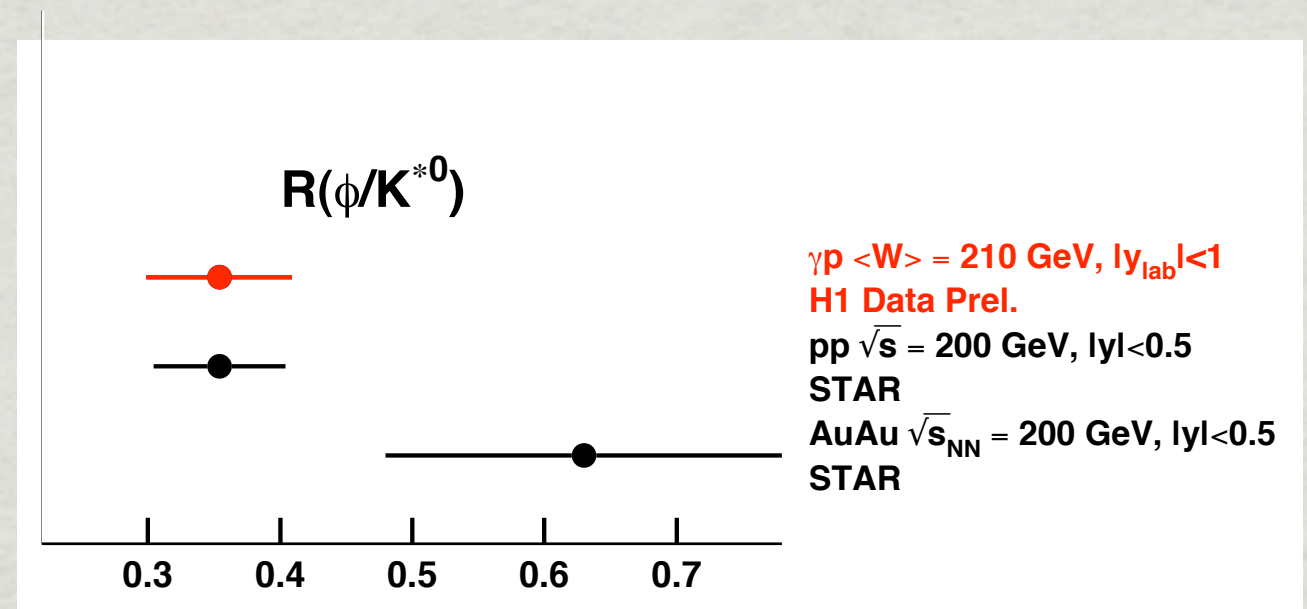

ENHANCED PRODUCTION OF ss QUARKONIUM STATE IN $AuAu$ COMPARED TO pp AND γp .

PYTHIA / PHOJET MONTE CARLOS
NEED $\lambda_s \sim 0.32$ TO DESCRIBE
THESE RATIOS

INCONSISTENT WITH DIS RESULTS

Bonus

$K^{*\pm}$ Production

$5 < Q^2 < 100 \text{ GeV}^2$

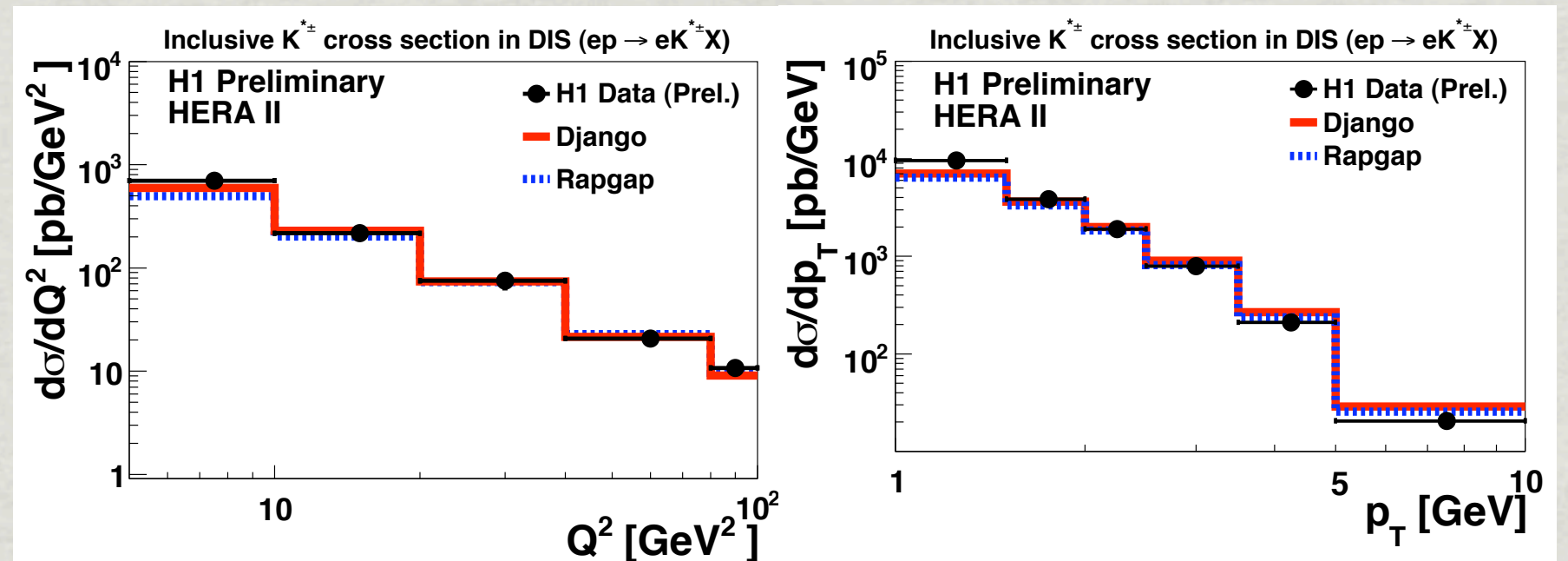
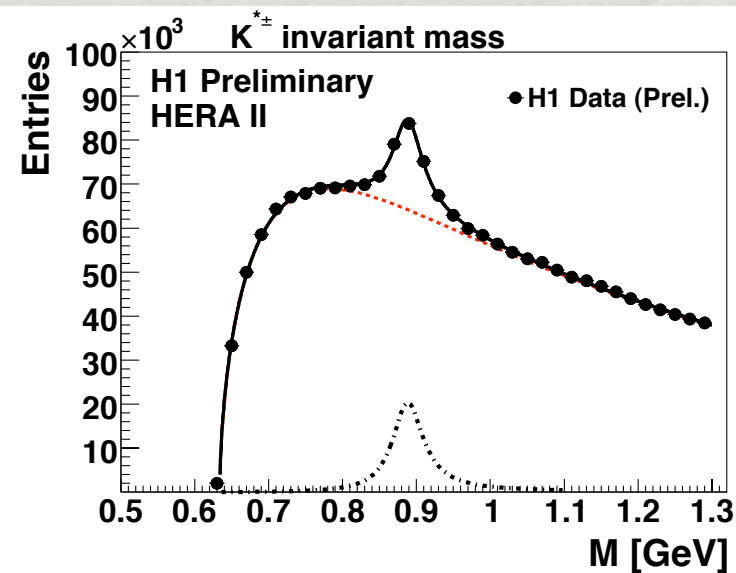
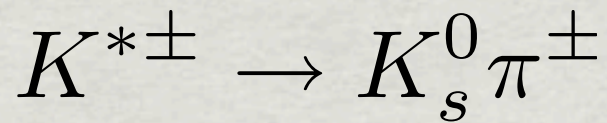

BASIC FEATURES DESCRIBED BY MONTE CARLO MODELS

USE CHARGE TO MEASURE s
 AND \bar{s} RATE, POSSIBLE
 SENSITIVITY TO STRANGENESS
 ASYMMETRY IN PROTON

$$x_F = 2P_L/W$$

HADRONIC CENTRE OF
 MASS FRAME

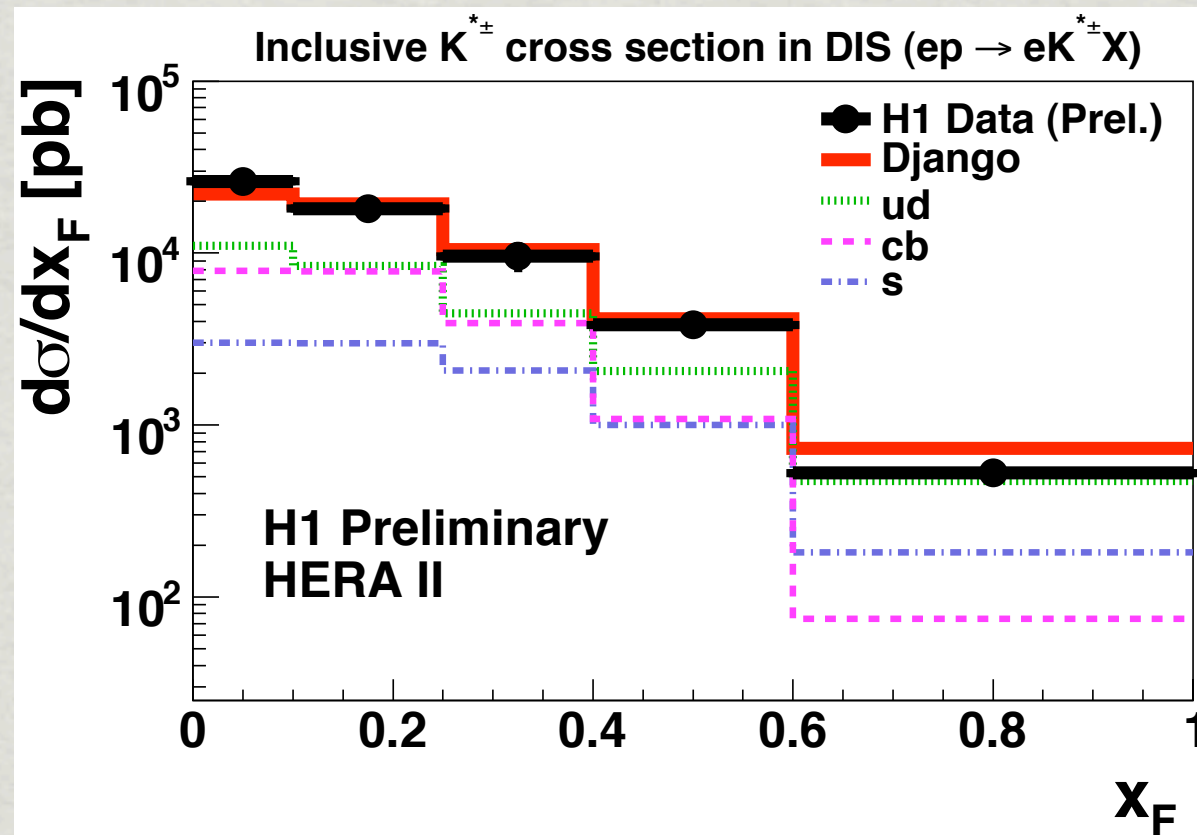

NON STRANGENESS
 DOMINATES HARD
 INTERACTION

INSTANTONS ARE NON-PERTURBATIVE FLUCTUATIONS OF THE GLUON FIELD. THEY REPRESENT TUNNELLING TRANSITIONS BETWEEN TOPOLOGICALLY NON-EQUIVALENT VACUA.

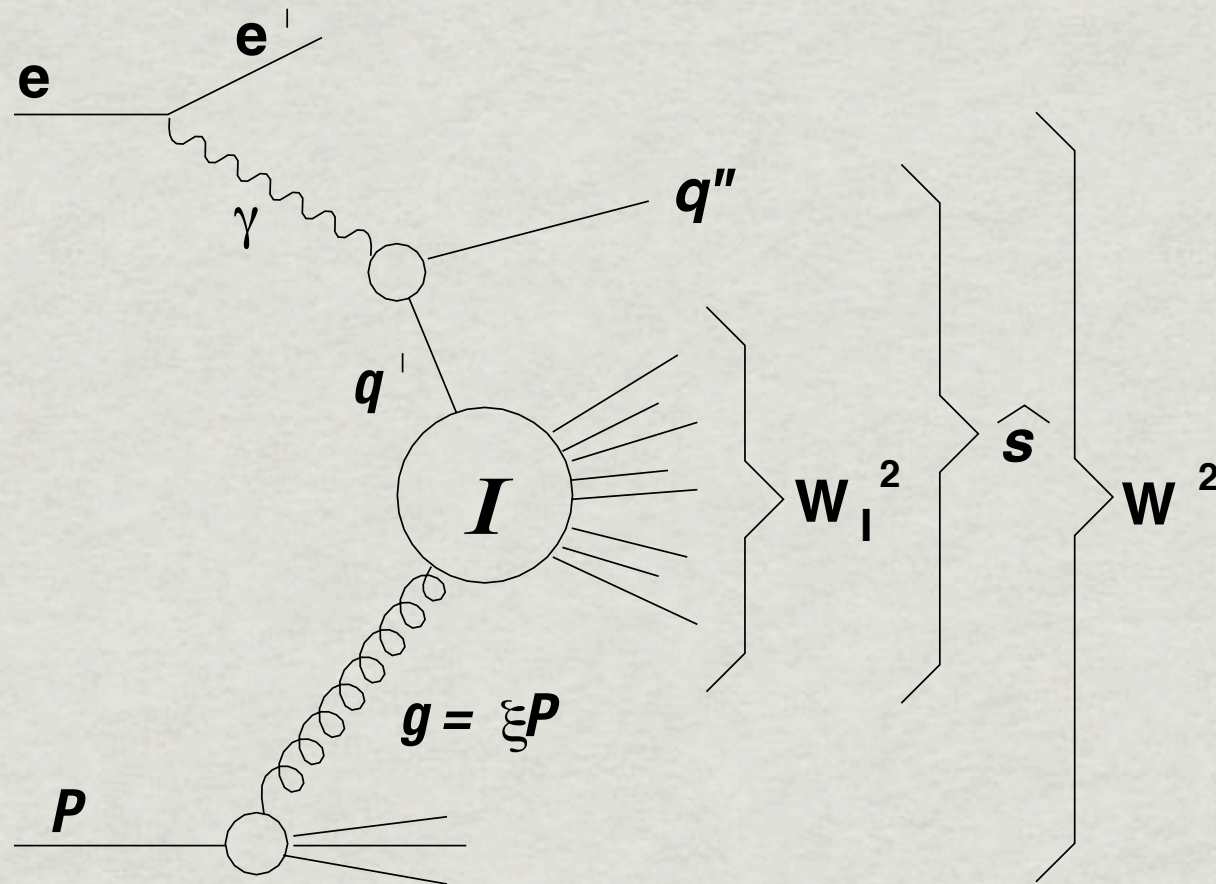

SIGNATURE- A LARGE NUMBER OF HADRONS AT HIGH TRANSVERSE ENERGY EMERGING FROM A "FIRE-BALL" LIKE TOPOLOGY.

THEY ARE REQUIRED BY QCD AND THEIR CROSS SECTION CAN BE CALCULATED, UNDER CERTAIN ASSUMPTIONS, IN QCD

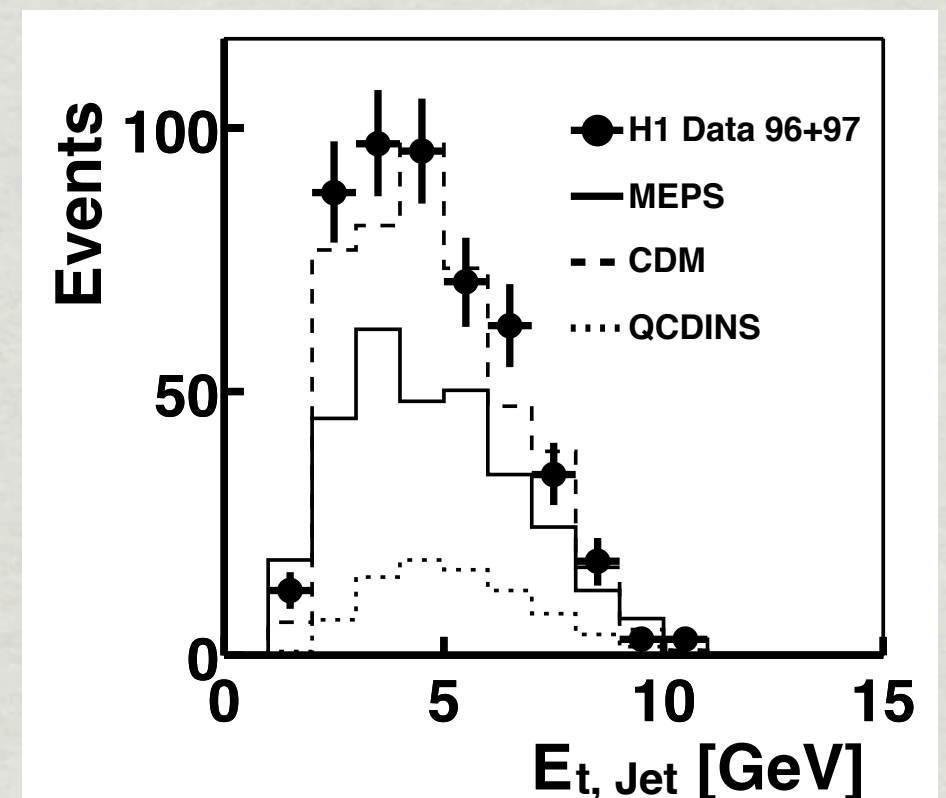

DIFFERENCES IN BACKGROUND PREDICTION LARGER THAN INSTANTONS CROSS SECTION

Pentaquarks

5 QUARK BOUND STATES

MOST RECENT ANALYSES AROUND THE WORLD HAVE PROVED NEGATIVE

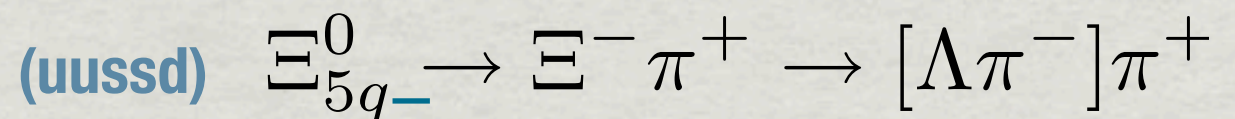
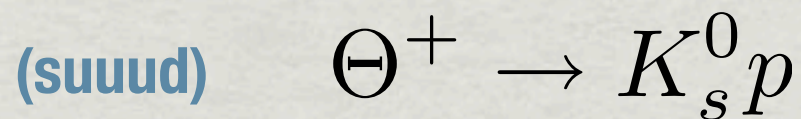
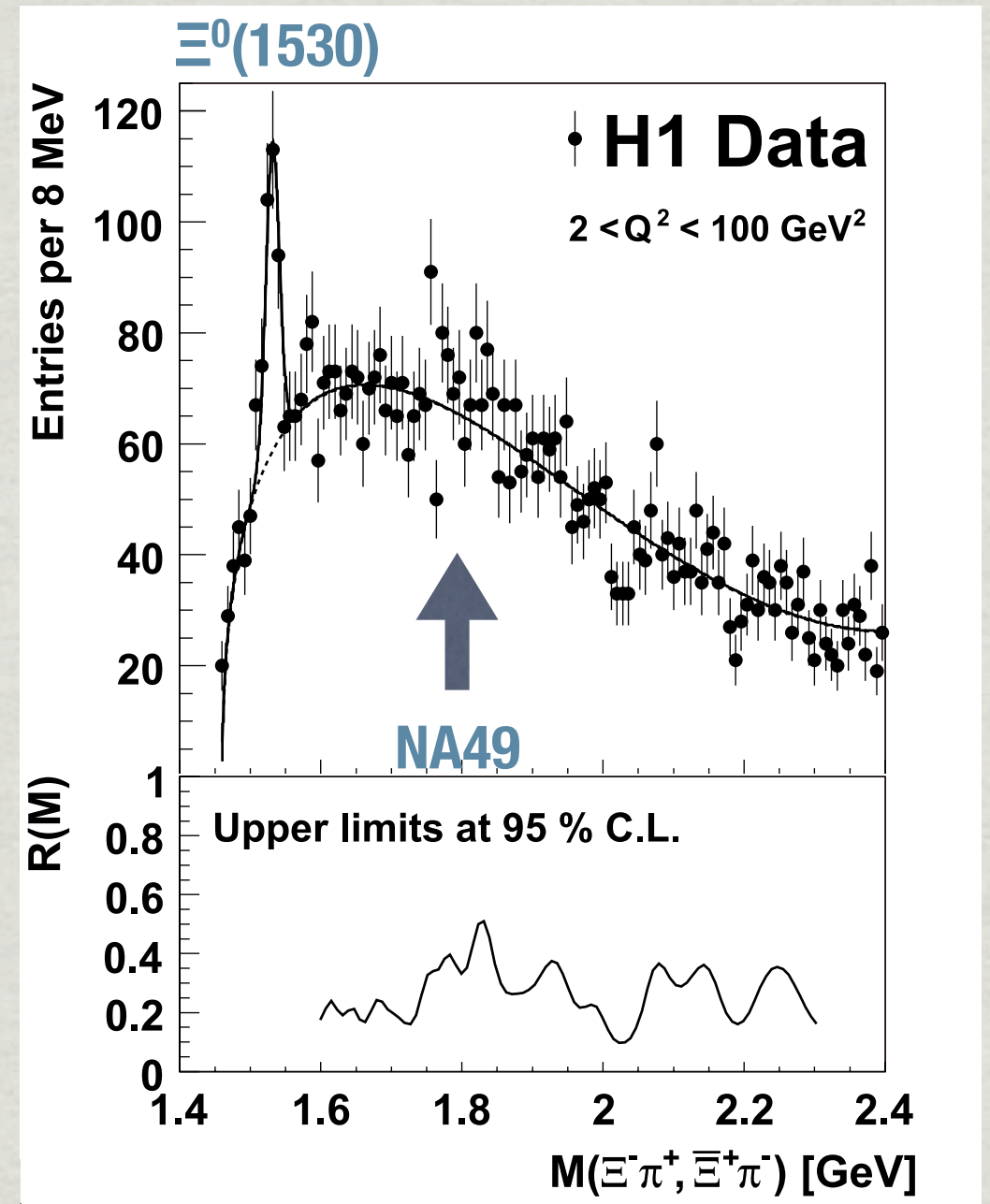
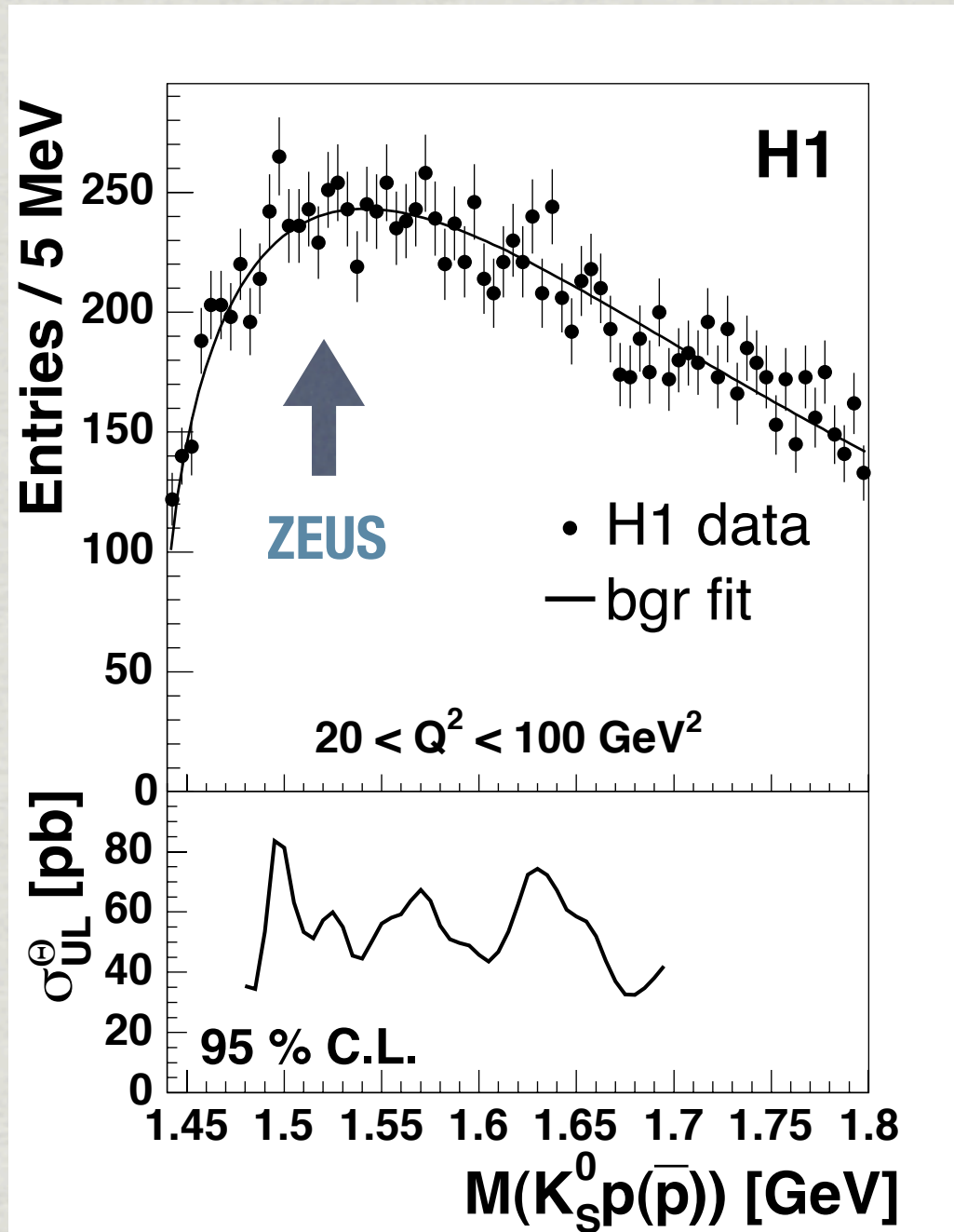

Charmed Pentaquarks

**H1 OBSERVED SIGNAL FOR A
CHARMED PENTAQUARK IN
HERAI DATA SET**

NO SIGNAL OBSERVED IN HERAII !

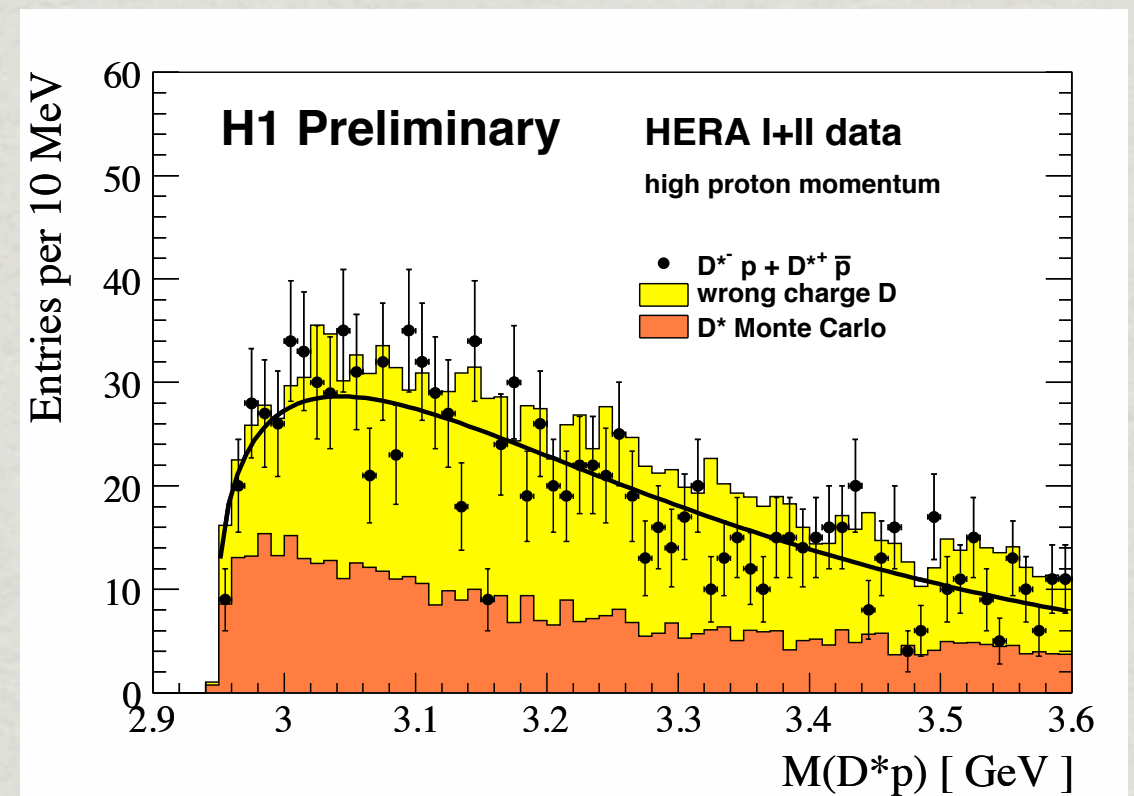
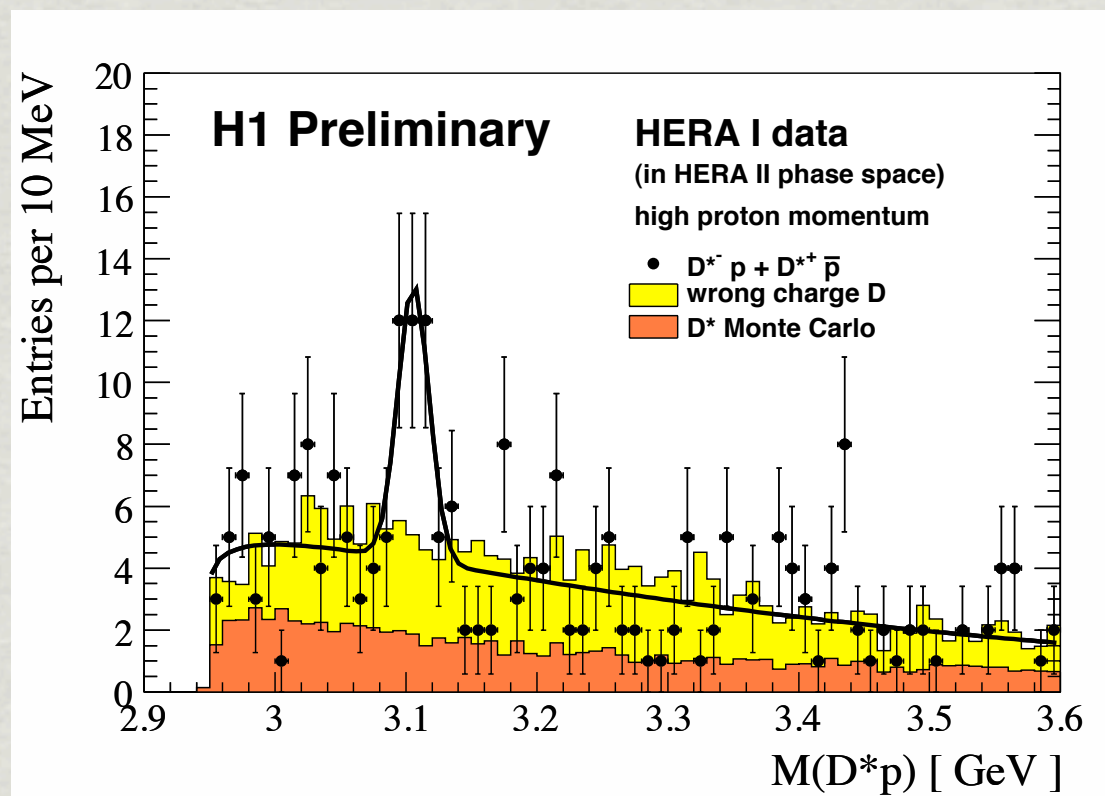

**OTHER EXPERIMENTS LOOKED
FOR IT BUT FAILED TO SEE
ANYTHING**

Glueballs

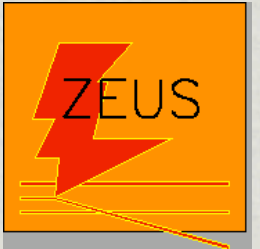

KOKO FINAL STATES

INTERFERENCE EFFECTS INCLUDED IN FIT

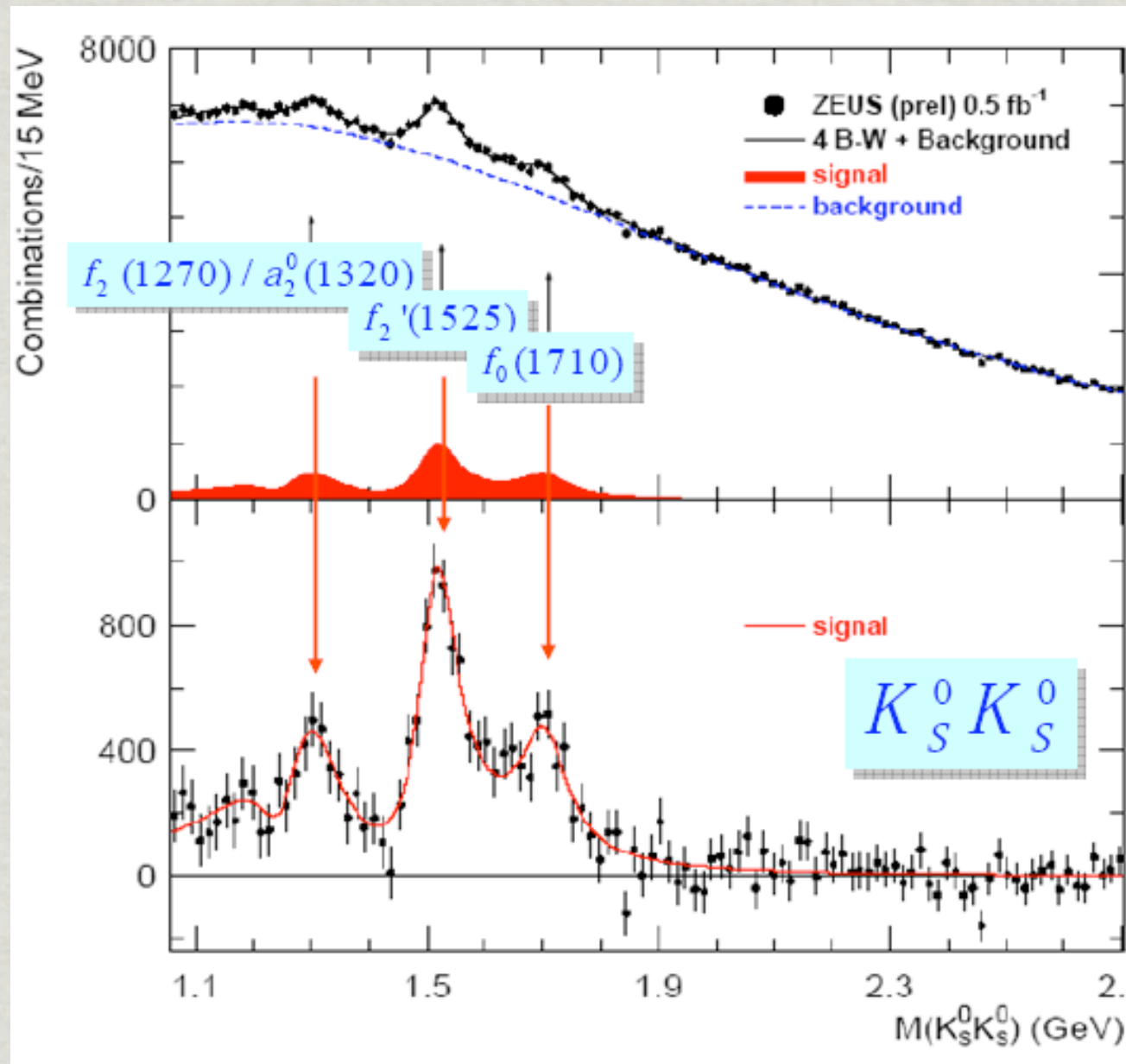

$$\gamma\gamma \rightarrow K_S^0 K_S^0$$

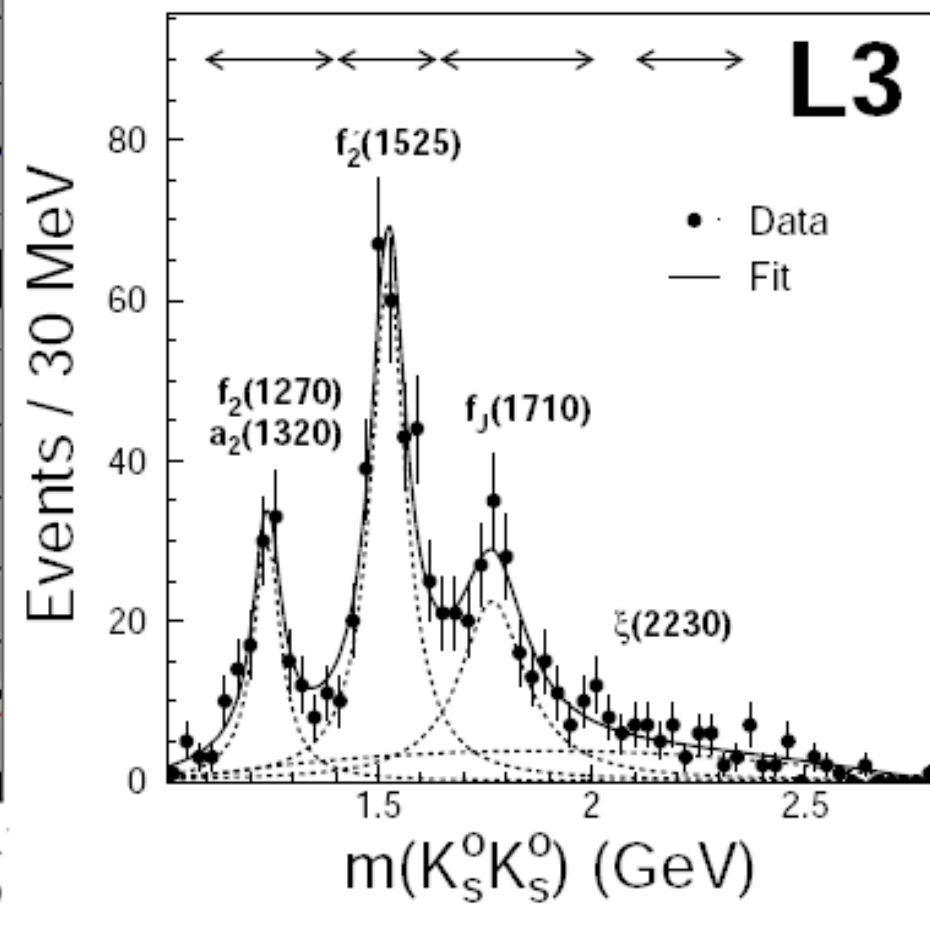

KOKO SYSTEM EXPECTED TO COUPLE TO SCALAR AND TENSOR GLUEBALLS, F01720 GLUEBALL CANDIDATE FROM LATTICE CALCULATIONS.

f₀(1710) CANNOT BE A PURE GLUEBALL, SINCE IT COUPLES TO $\gamma\gamma$. MUST THEREFORE MIX

Summary

- * With HERA data there is the possibility to study many different aspects of (np)QCD via particle production.
- * Universality of fragmentation broadly supported BUT there are differences in detail when comparing to models (NLO FF, λ_s , string length etc...).
- * Expect further results on strangeness, instantons, underlying event, multi parton dynamics.

Summary

**QCD IS CLEVER BUTS ITS NOT THAT
CLEVER**

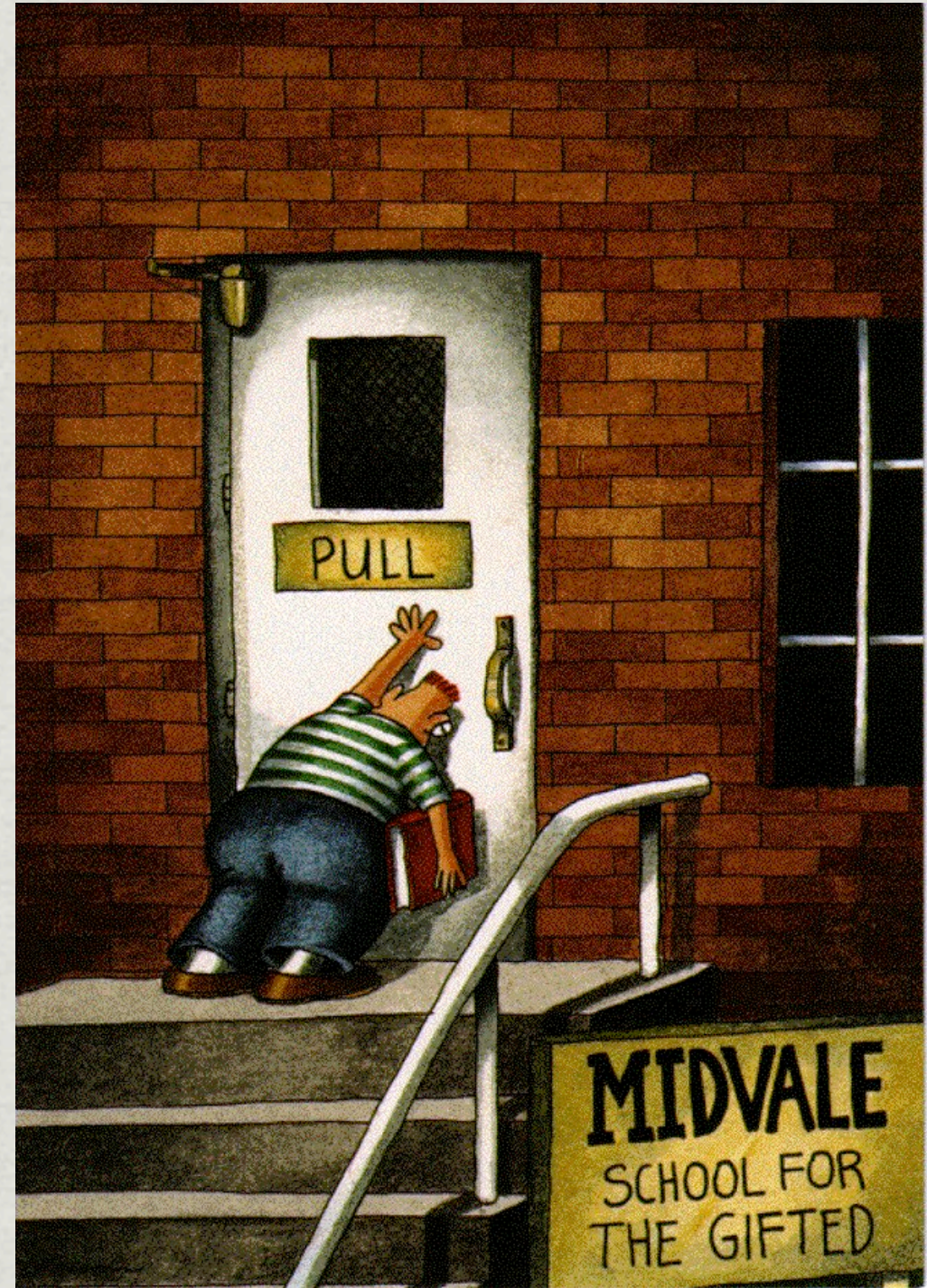

backup

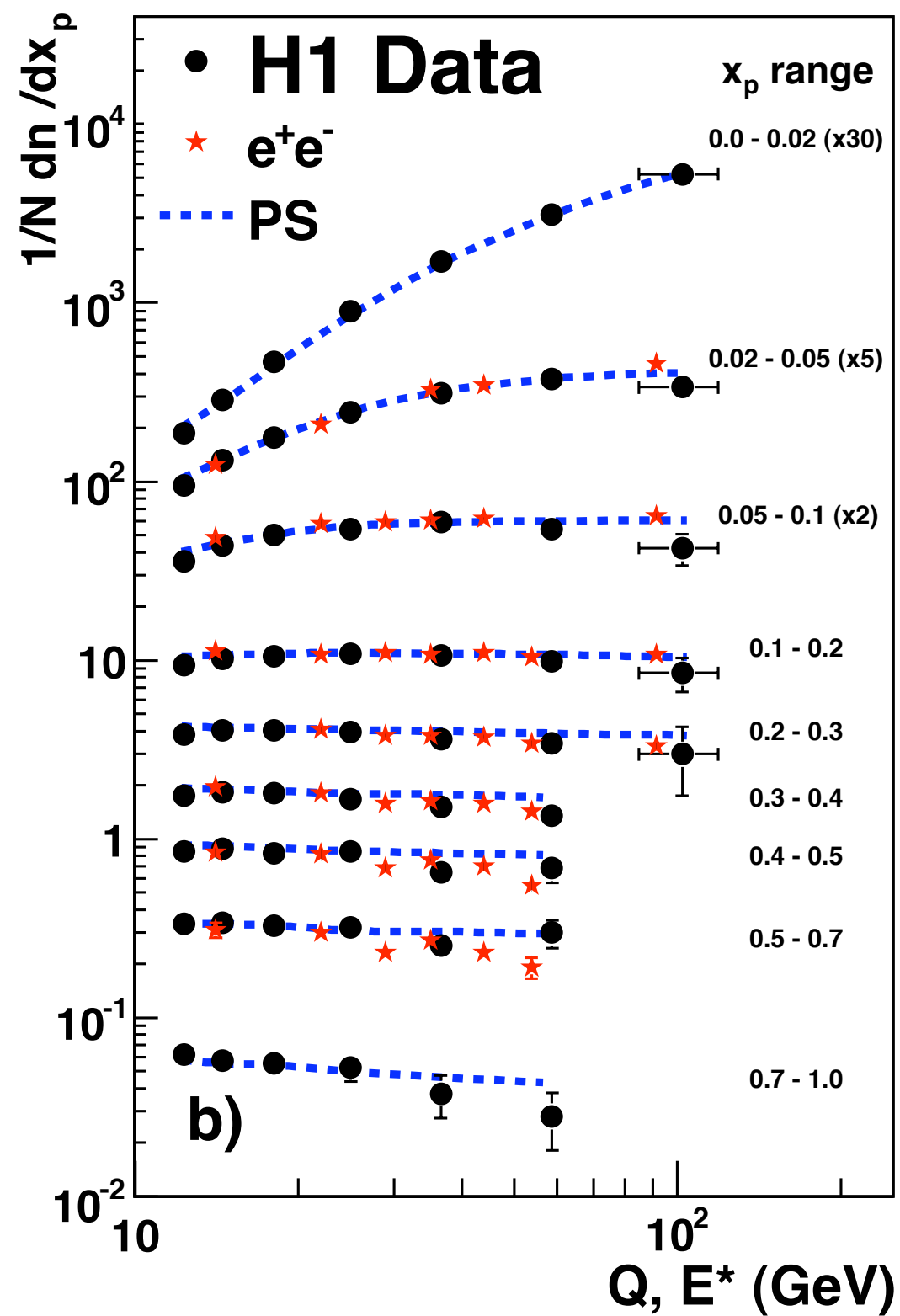
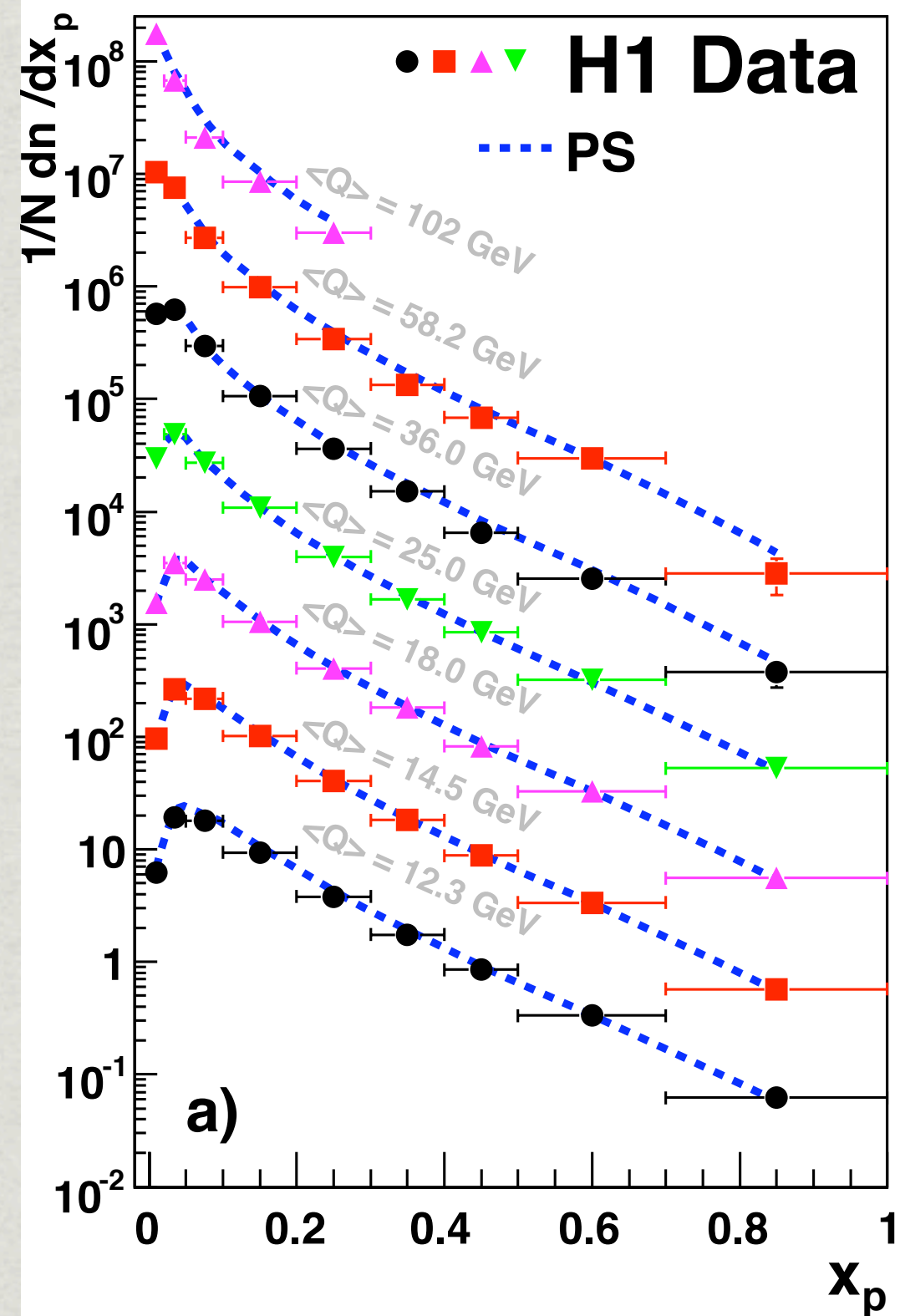

one x_p bin in detail

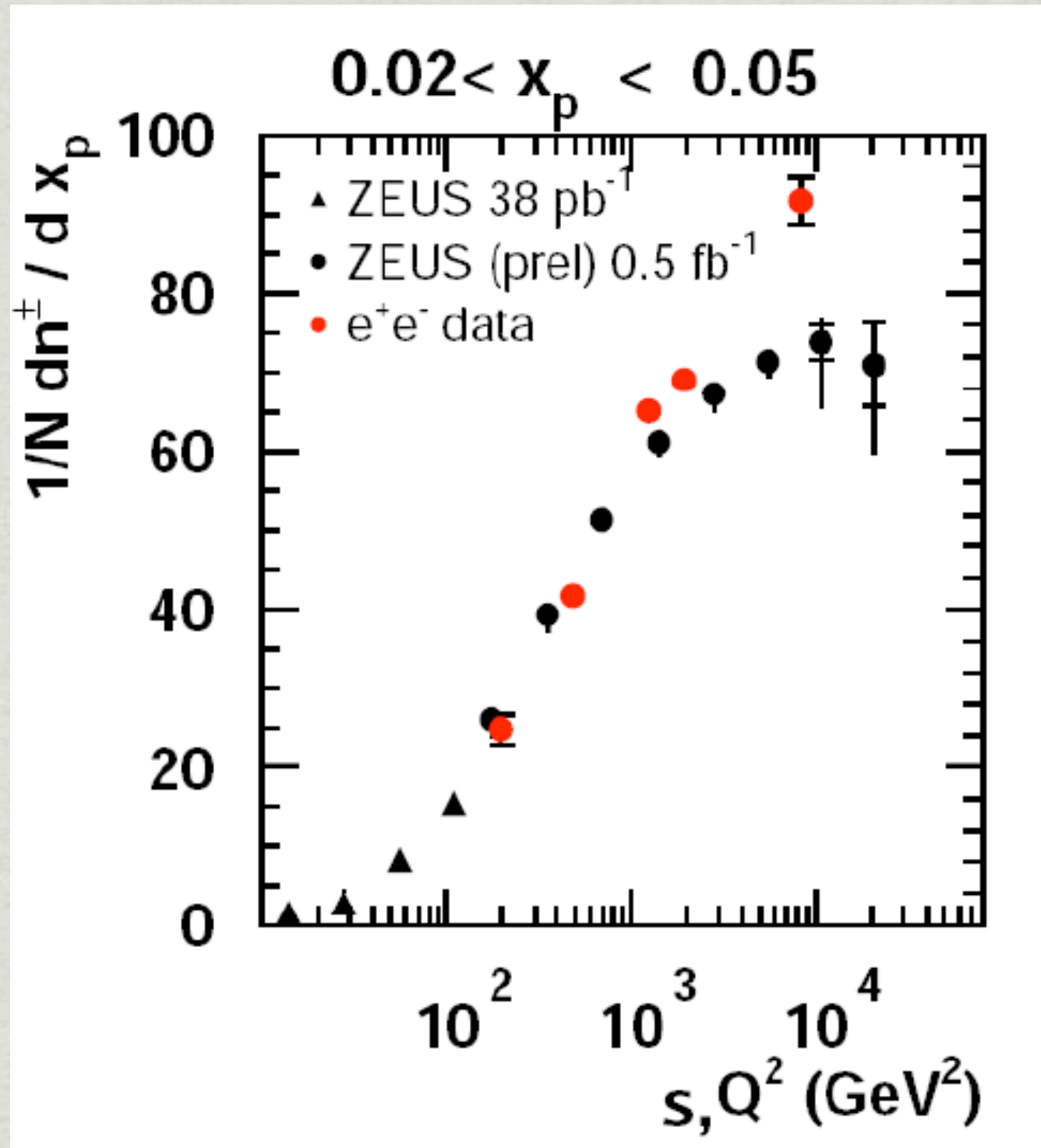

Strong scaling violation at this low x_p .

Deviation between e⁺e⁻ and ep at highest s or Q^2 .

Strangeness production ratio

$$(\Lambda + \bar{\Lambda})/K_s^0$$

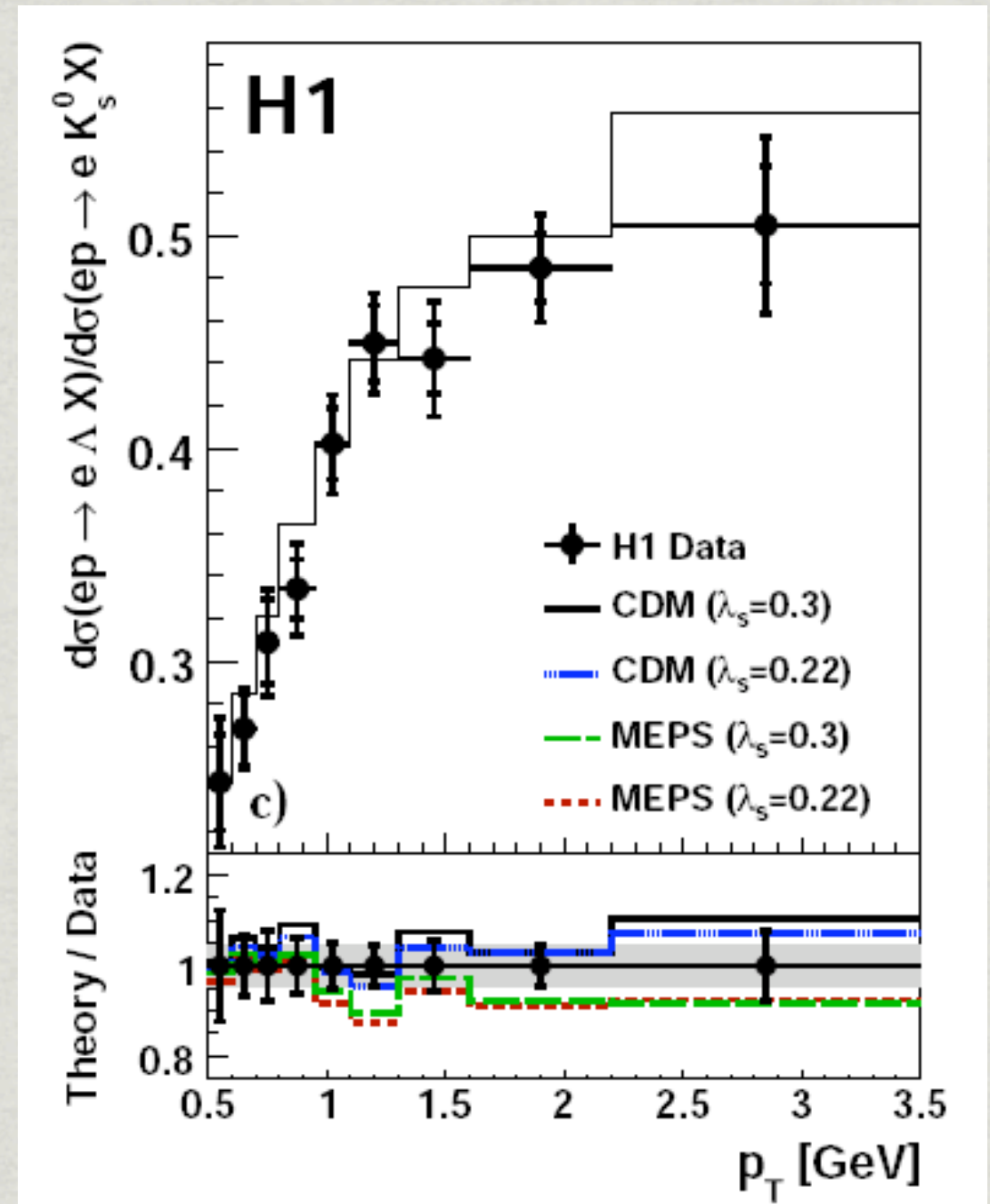
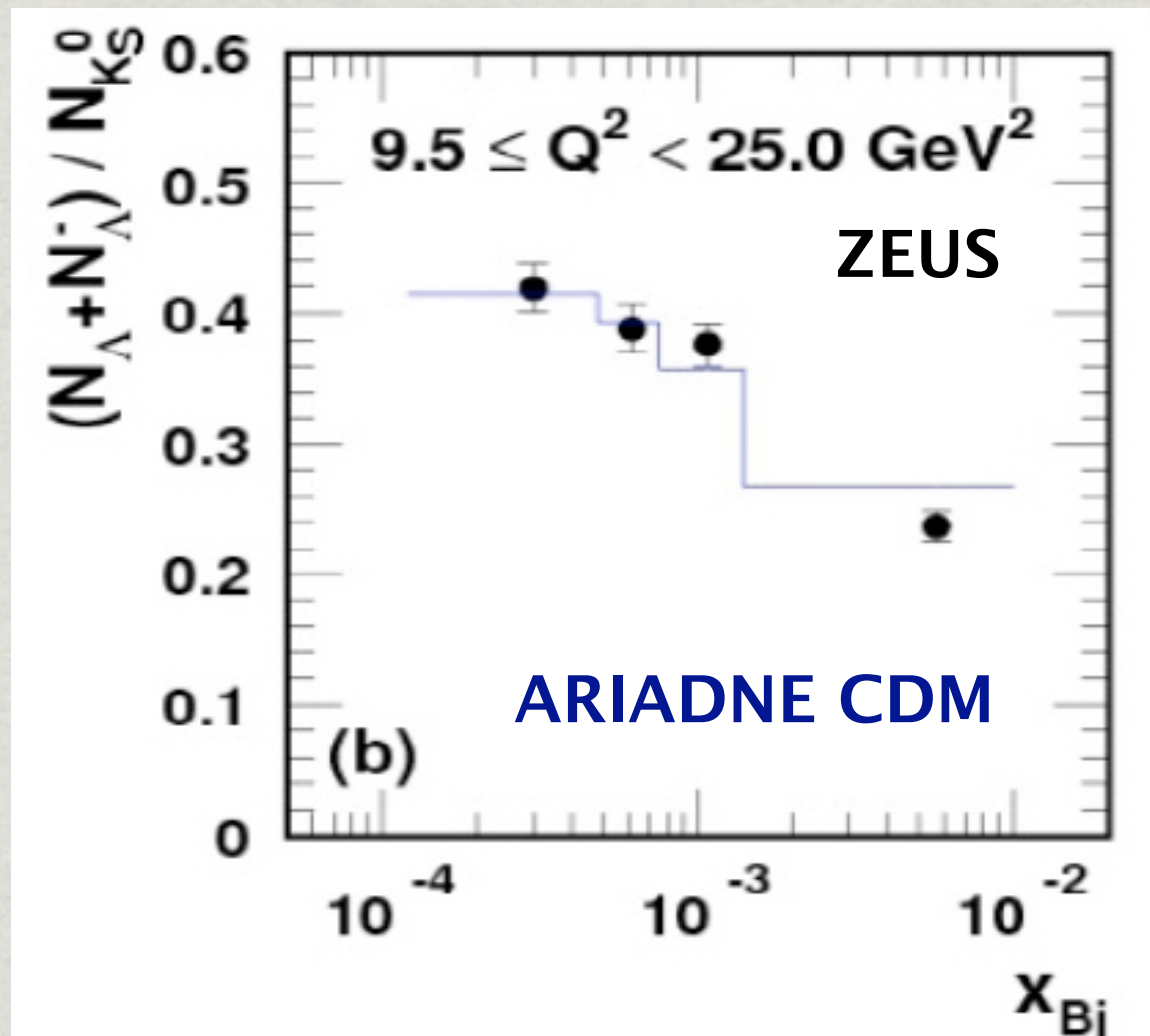

Color dipole model with $\lambda_s = 0.3$ gives best description (not perfect).

K^0 to charged hadron ratio

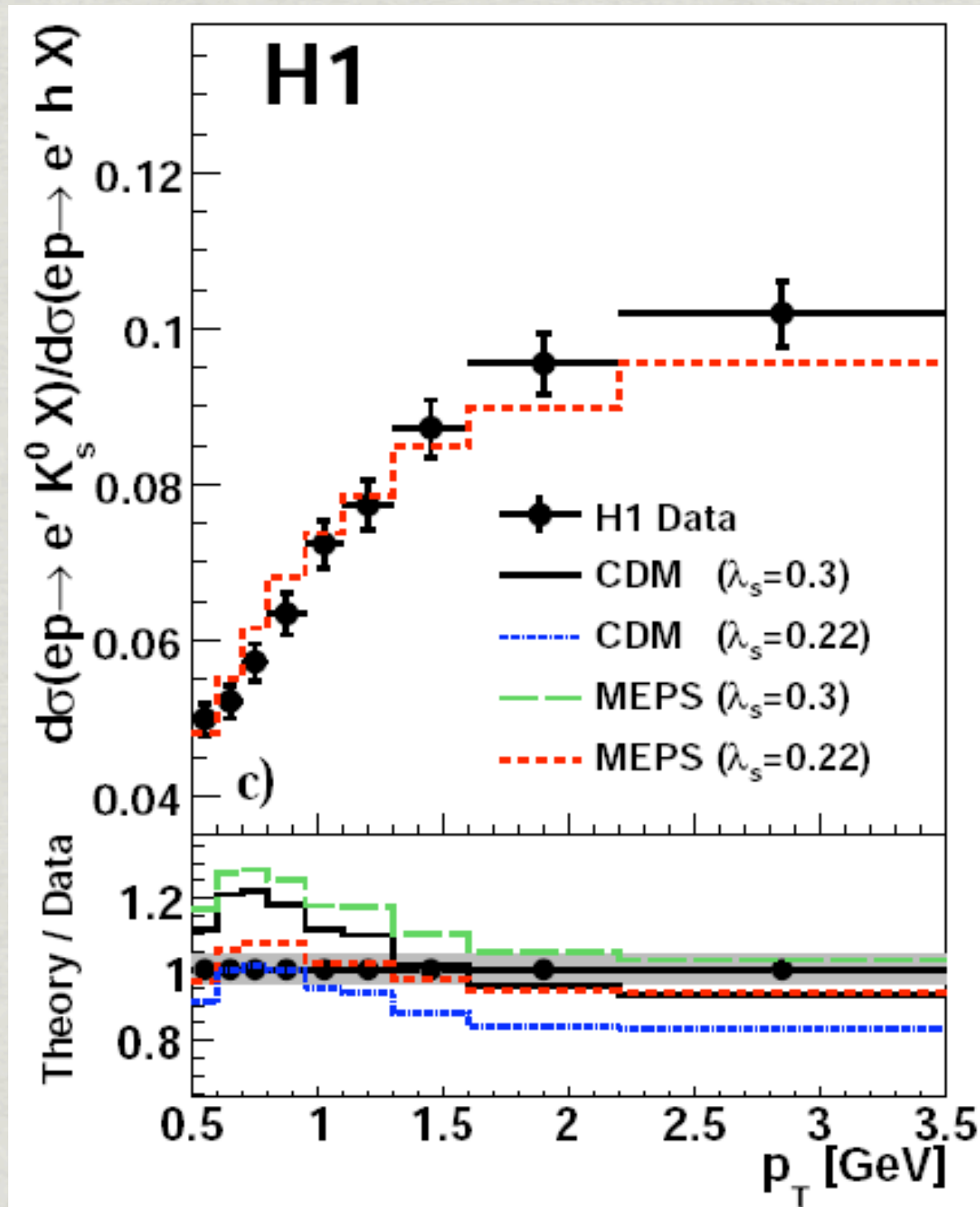

Ratio K^0/h has less sensitivity to PDFs and hard scattering process. Enhanced sensitivity to details of strangeness production.

Ratio $K/hadrons$ best described by MEPS with smaller $\lambda_s = 0.22$.

No single combination of model and λ_s describes all data.

Deuteron production

Coalescence model:

$$\frac{1}{\sigma} \frac{d^3 \sigma(d)}{d^3 p} = B_2 \left(\frac{1}{\sigma} \frac{d^3 \sigma(p)}{d^3 p} \right) \left(\frac{1}{\sigma} \frac{d^3 \sigma(n)}{d^3 p} \right)$$

$B_2(d) = B_2(\bar{d})$ is expected

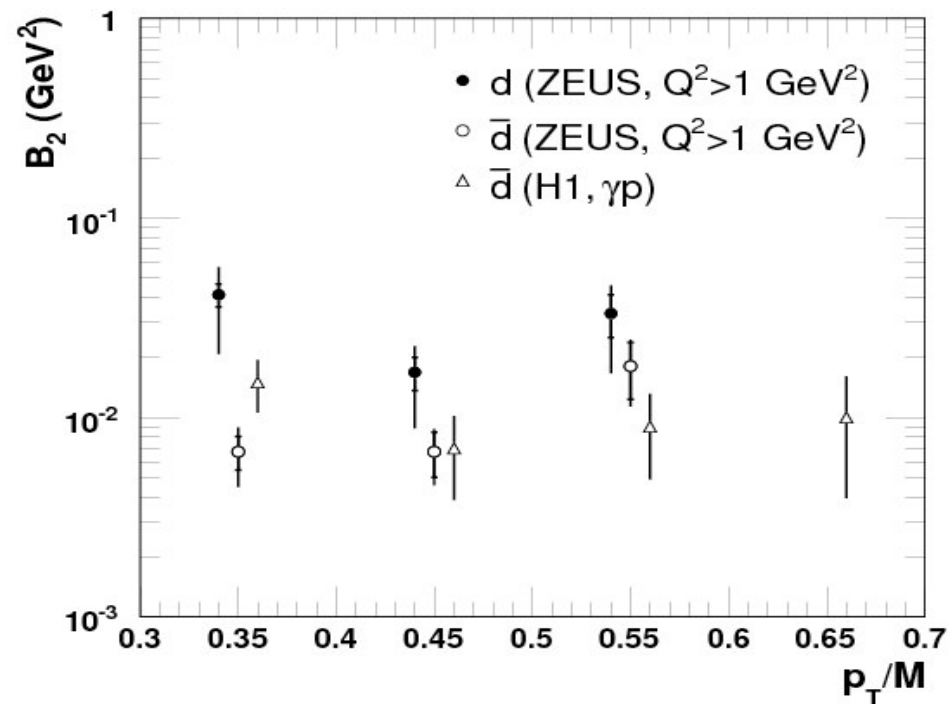

$$B_2(d) = 3.32 \pm 0.34^{+1.13}_{-1.55}$$

$$B_2(\bar{d}) = 0.89 \pm 0.14^{+0.19}_{-0.20}$$

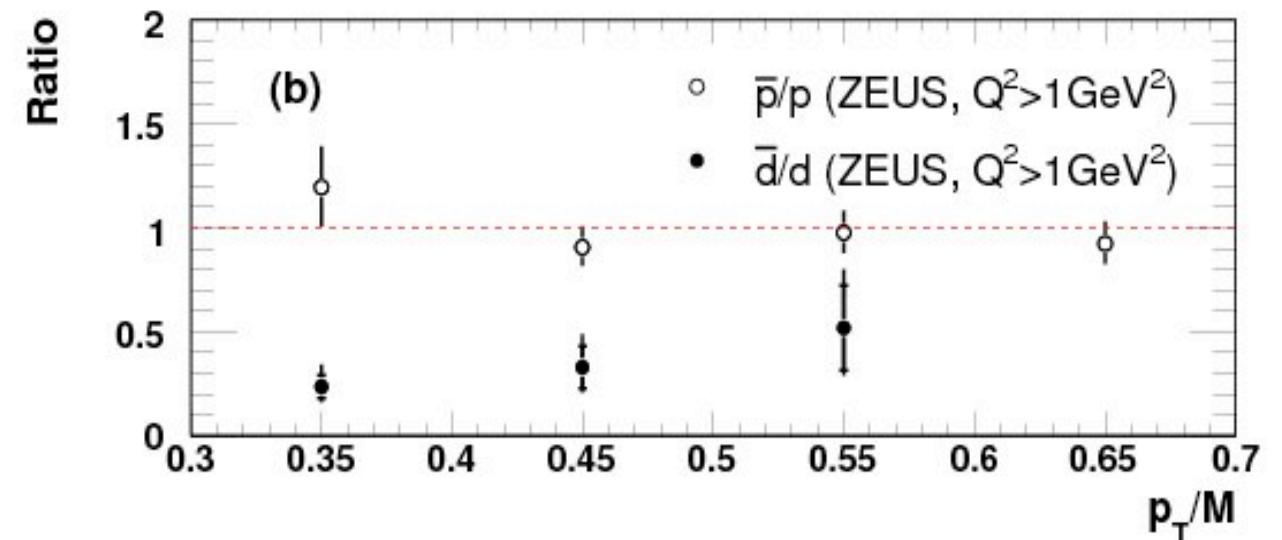
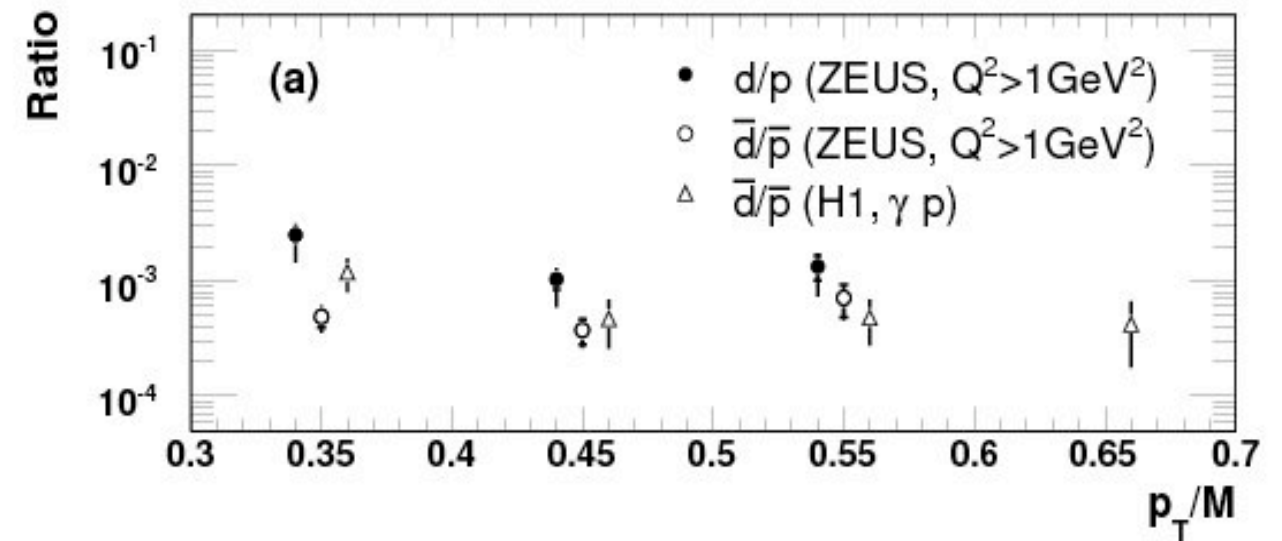

Enhanced production of multi-quark states?